



robert abbey
fine lighting



Photo by Cate Black Photography

Collections

AARON
ADDISON
ALBERT
ALICE
ALLOY
ALSTON
ANDRE
ANDROMEDA
ANENOME
ANNA
ANNIKA
APOLLO
ARCHER
ARTEMIS
ARTHUR
ATHENA
AUDREY
AXIOM
AXIS
BANDIT
BEAUX ARTS
BEEHIVE
BELVEDERE
BLING
BLOX
BRADLEY
BRAXTON
BRIGHTON
BRUNO
BRYCE
CAMPBELL
CEDRIC
CELESTE
CELINE
CHARLEE
CHASE
CHLOE
CINCH
COLE
COOPER
COSMOS
CRISTALLO
CURTIS
DAL
DAPHNE
DECKER
DELANY
DELILAH
DELTA
DEXTER
DIANA
DIRECTOR
DOLLY
DOUBLE GOURD
DOUGHNUT
ECHO
ELENA
EMPIRE
FERDINAND
FINEAS
FLETCHER
FRANKLIN
FUSION
GEMMA
GLASS HARRIET

GLORIA
GOLIATH
GRACE
GRAVITY
HALO
HARVEY
HORIZON
JASMINE
JEANNIE
JUNE
JUNO
KATE
KINETIC
KOLEMAN
LATITUDE
LEDGER
LINCOLN
LOGAN
MARCEL
MARGEAUX
MASON
MUSE
NIKOLE
NOVA
OCULLUS
OLIVER
ORION
PEARL
PEEK
PENELOPE
PIERCE
PIKE
RANGER
RAQUEL
REAL SIMPLE
RODERICK
RUBIX
SATURNIA
SIMON
SLOAN
SOFIA
THATCHER
TIC-TAC-TOE
TRIPLE GOURD
TYRONE
VALERIE
VICTOR
WAVY
WHEATLEY
WILTON
WONTON
WYATT
ZOLTAR
RICO ESPINET ARIAL
RICO ESPINET BUMPER
RICO ESPINET BUSTER
RICO ESPINET CANDELARIA
RICO ESPINET LUA VESSAL
RICO ESPINET MARINA
RICO ESPINET MILES
RICO ESPINET NINA
RICO ESPINET OLINDA
RICO ESPINET OVO
RICO ESPINET RACER
RICO ESPINET SCOUT

RICO ESPINET SHINTO
JONATHAN ADLER BELLPORT
JONATHAN ADLER BIARRITZ
JONATHAN ADLER BRISTOL
JONATHAN ADLER CANAAN
JONATHAN ADLER CAPRI
JONATHAN ADLER CERAMIC
JONATHAN ADLER CLARIDGE
JONATHAN ADLER GENEVA
JONATHAN ADLER HARLEQUIN
JONATHAN ADLER HAVANA
JONATHAN ADLER HOLLYWOOD
JONATHAN ADLER JUPITER
JONATHAN ADLER MAXIME
JONATHAN ADLER MEURICE
JONATHAN ADLER MILANO
JONATHAN ADLER MONACO
JONATHAN ADLER MYKONOS
JONATHAN ADLER PARKER
JONATHAN ADLER RIO
JONATHAN ADLER SATURN
JONATHAN ADLER SPUTNIK
JONATHAN ADLER TOTEM
JONATHAN ADLER VENTANA
JONATHAN ADLER VERSAILLES
JONATHAN ADLER VIENNA
MAVISTEN EDITION COPERNICA
MAVISTEN EDITION FAR
WILLIAMSBURG CUSTIS
WILLIAMSBURG FINNIE
WILLIAMSBURG LIGHTFOOT
WILLIAMSBURG ORLANDO
WILLIAMSBURG RANDOLPH
WILLIAMSBURG SPOTSWOOD
WILLIAMSBURG TAZEWELL
WILLIAMSBURG TUCKER
WILLIAMSBURG TYRIE
MICHAEL BERMAN ATLAS
MICHAEL BERMAN BOND
MICHAEL BERMAN BRUT
MICHAEL BERMAN HADRIAN
MICHAEL BERMAN NOLAN



We are proud to present our new 2022 catalog to you, our loyal customers. We hope the information in this catalog inspires your creativity and promotes success.

Robert Abbey has always been about family. Our company continues to be family owned and operated for more than seven decades. We pride ourselves in the passion and dedication our founding members have instilled in us, while we look ahead at new possibilities and growth in an ever-changing market.

Robert Abbey is located in the foothills of Western North Carolina. Comprised of a 250,000 square foot facility ranging from offices, full manufacturing, and warehouse. We take pride in manufacturing an assortment of our diverse line in the USA. Continuing to manufacture products in the US has given Robert Abbey the flexibility to create fine lighting at an unparalleled value.

We are especially proud of our collaborations with top designers such as Jonathan Adler, Rico Espinet, Michael Berman, and Colonial Williamsburg who trust Robert Abbey to create lighting products that meet their high standards of quality and refinement.

Our showrooms in High Point and Dallas continue to be exciting arenas for collaboration and exchanging ideas. Our goal has always been to help ensure our customer's success. We look forward to your next visit to one of our showrooms.

Please continue to visit our website www.robertabbey.com for the latest product assortment and information.

Best regards,

Mary J Rose
President

Nathan Hedrick
Director of Operations

3166 MAIN AVENUE S.E. HICKORY, NC 28602 | 828.322.3480 | FAX 828.328.1037

PERMANENT SHOWROOM

DALLAS, TX WTC 305-1

www.robertabbey.com





703



646

Aaron

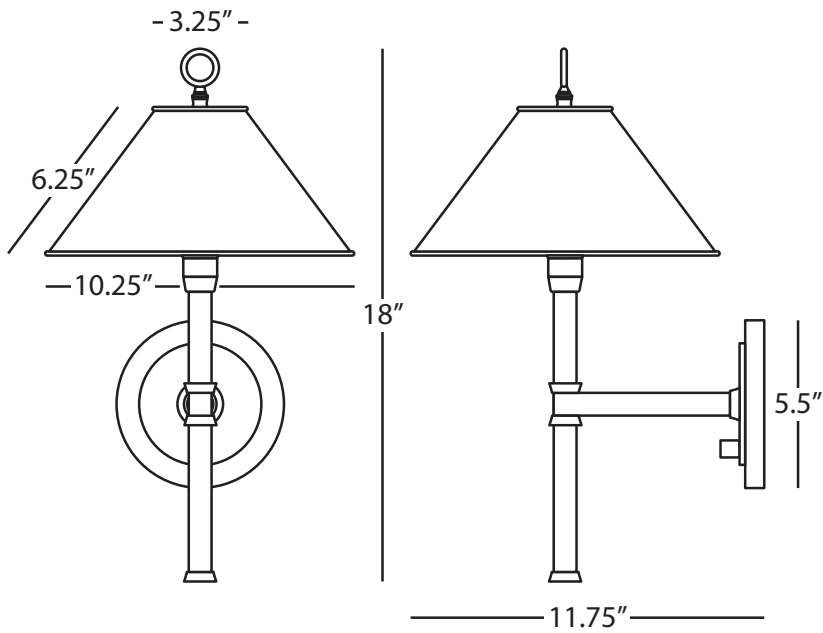

AARON

646

Wall Sconce

1 - 60W Max.
Bulb Type: B, Candelabra Base
Switch: Hi-Lo Dimming
24" Cord Cover/ Direct Wire
Deep Patina Bronze Finish
Warm Brass Accents
Metal Shade

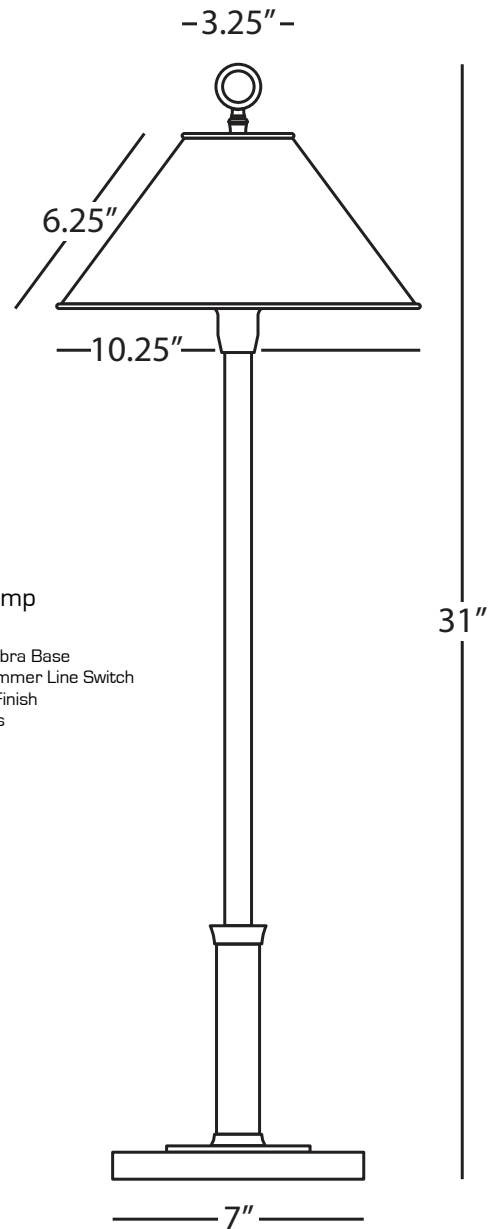

AARON

703

Buffet Table Lamp

1 - 60W Max.
Bulb Type: B, Candelabra Base
Switch: Full Range Dimmer Line Switch
Deep Patina Bronze Finish
Warm Brass Accents
Metal Shade



1573



1545

Addison

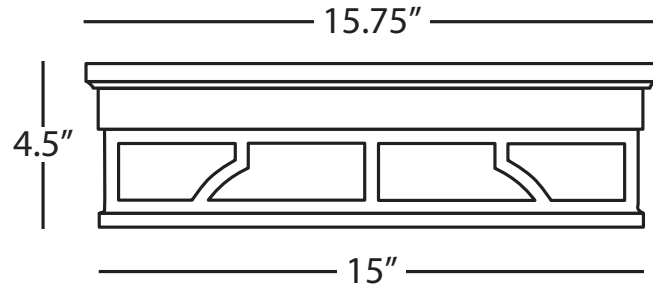

ADDISON

1573

Flush Mount

2 - 60W Max.
Bulb Type: A
Direct Wire
Weathered Brass Finish
White Glass Shade Panels

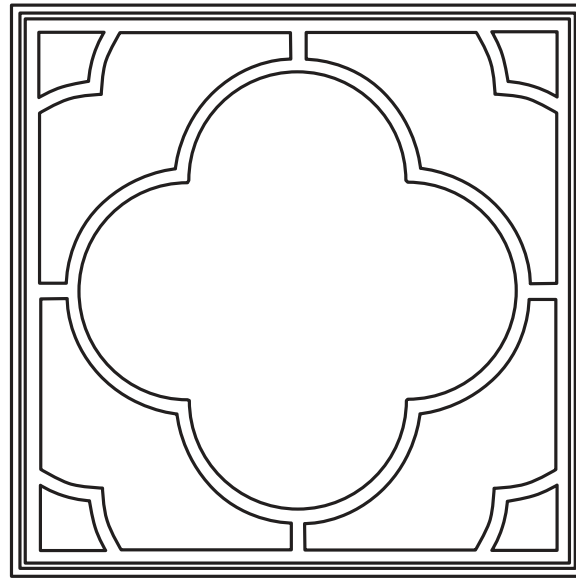

ADDISON

1545

Semi-Flush Mount

2 - 100W Max.
Bulb Type: A
Direct Wire
Patina Nickel Finish
Pearl Dupioni Fabric Shade
w/ Decorative Metal Band
17.5" Dia. White Acrylic Diffuser

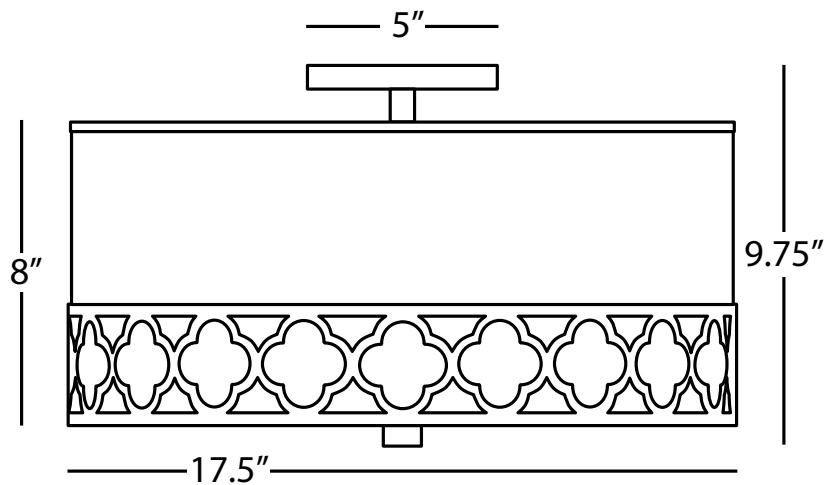

FINISH/SHADE OPTION:
1575 Weathered Brass
Taupe Dupioni



S746



Z743



P745

ALBERT

S746

Pendant

1 - 100W Max.
 Bulb Type: A
 Direct Wire
 Polished Nickel Finish
 Clear Glass Shade
 Susp. Hardware: 12 Ft. Black Fabric
 Wrapped Cord

Ships with Historical Bulb
 [HISO1 See page 225]

FINISH OPTIONS:

P746 Patina Nickel
Z746 Deep Patina Bronze

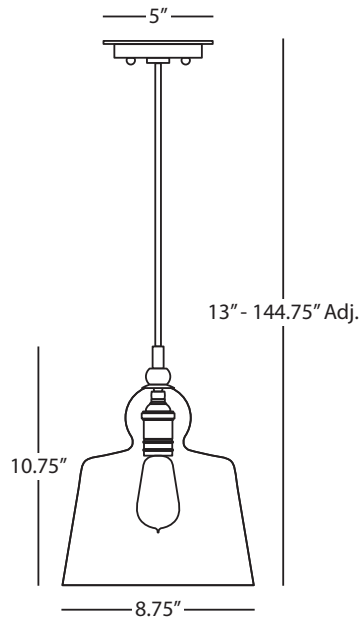

ALBERT

Z743

15" Pendant

1 - 100W Max.
 Bulb Type: A
 Direct Wire
 Patina Nickel Finish
 Clear Glass Shade
 Susp. Hardware: 12 Ft. Black Fabric
 Wrapped Cord

Photographed with Historical Bulb
 SOLD SEPARATELY (Style # HISO1)
 See Page 225)

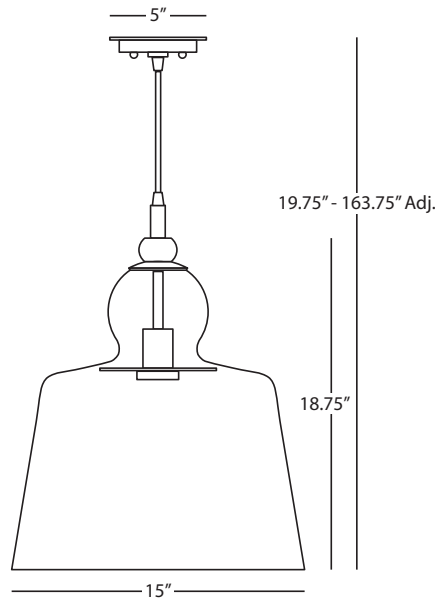

ALBERT

P745

Wall Sconce

1 - 60W Max.
 Bulb Type: A
 Direct Wire Only
 Patina Nickel Finish
 Clear Glass Shade

Ships with Historical Bulb
 [HISO1 See page 225]

FINISH OPTIONS:

S745 Polished Nickel
Z745 Deep Patina Bronze

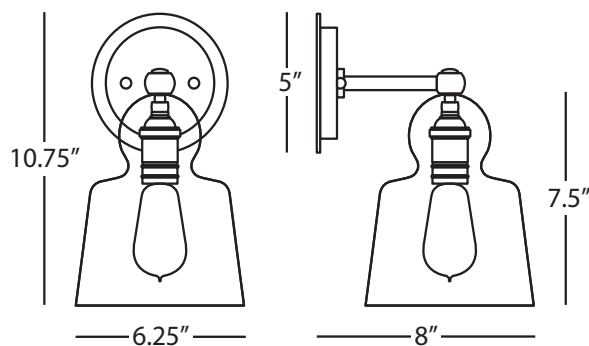



S3381



3381



S3380

Alice

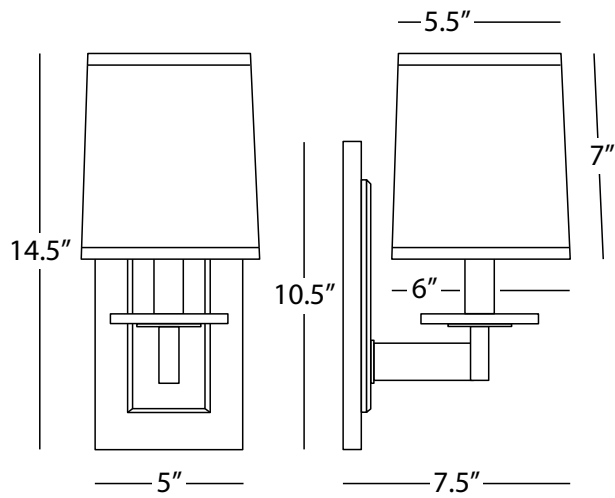

ALICE

3381 Wall Sconce

1 - 60W Max.
Bulb Type: B, Candelabra
Switch: On-Off Line Switch
24" Cord Cover/Direct Wire
Antique Brass Finish w/
Lucite Accents
Pearl Dupioni Fabric Shade

FINISH OPTION:
S3381 Polished Nickel

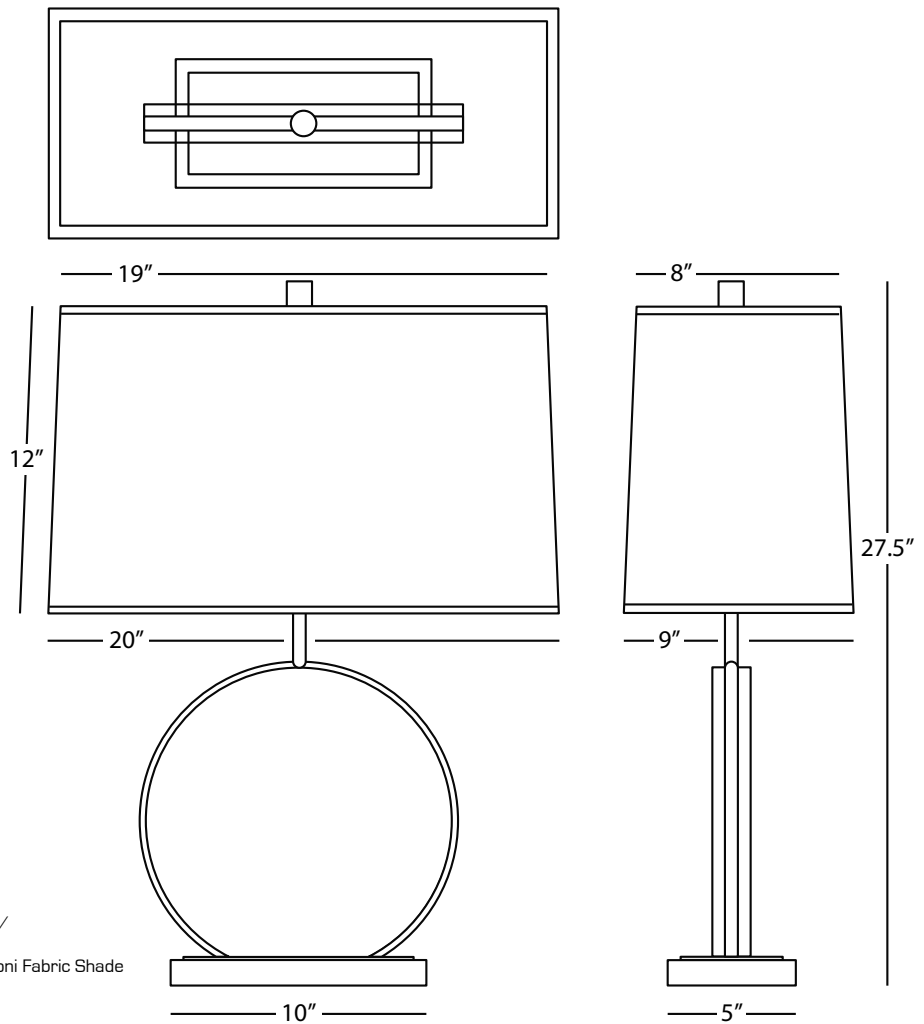

ALICE

S3380 Table Lamp

1 - 150W Max.
Bulb Type: A
Switch: Hi-Lo Dimming
Polished Nickel Finish w/
Lucite Accents
Rectangular Pearl Dupioni Fabric Shade



Z2418



S2418



2418

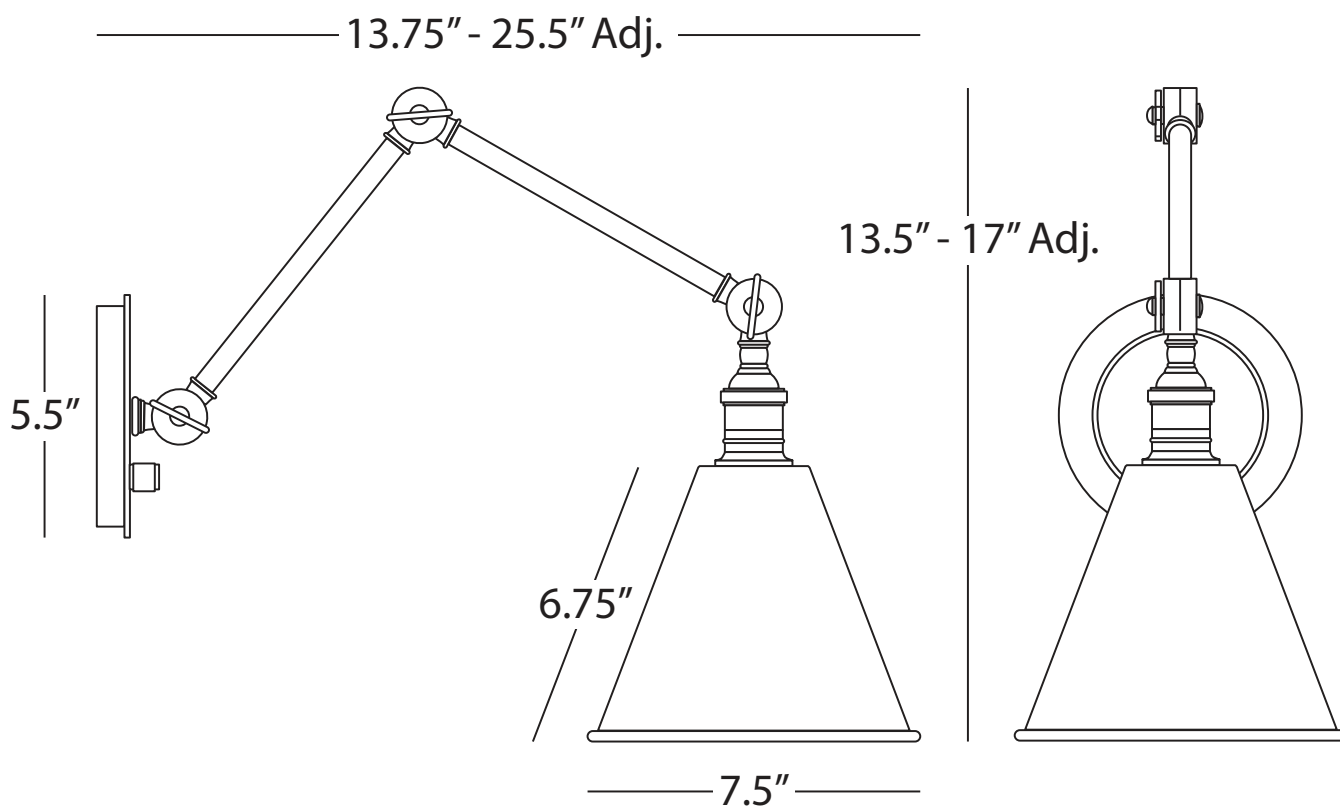

ALLOY

2418

Adjustable Wall Sconce

1 - 60W Max.
Bulb Type: A
Switch: Hi-Lo Dimming
24" Cord Cover/Direct Wire
Warm Brass Finish
Matching Metal Shade

FINISH OPTIONS:

S2418 Polished Nickel
Z2418 Deep Patina Bronze

Alston



Alston

[Click photo above to watch Alston Floor Lamp Video](#)

The Alston collection conveys a beautiful sense of balance and harmony in its design and combination of materials. Decorative and distinguished, Alston also provides warm, ambient light for your space.

Alston



Alston

[Click photo above to watch Alston Table Lamp Video](#)

The Alston collection conveys a beautiful sense of balance and harmony in its design and combination of materials. Decorative and distinguished, Alston also provides warm, ambient light for your space.



S456



455

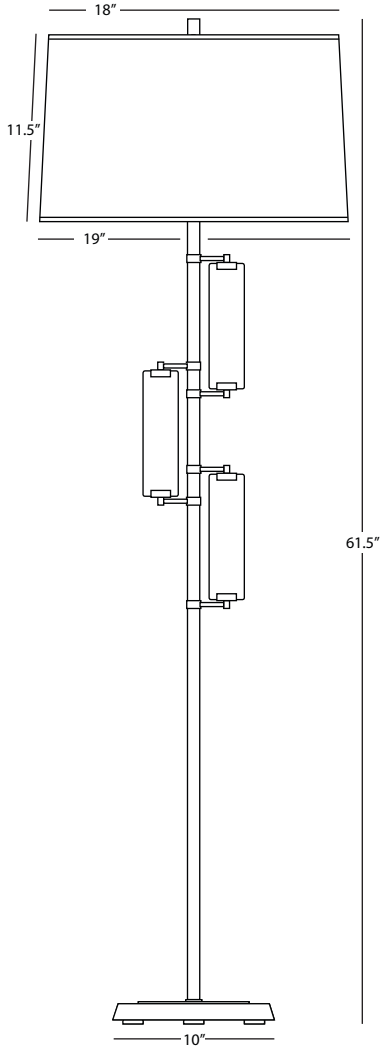

Alston

S456
Floor Lamp

1- 150W Max.
Bulb Type: A
Switch: Full Range Dimmer
Polished Nickel Finish
Carrara Marble Accents
Oyster Linen Shade

FINISH OPTIONS:
456 Modern Brass

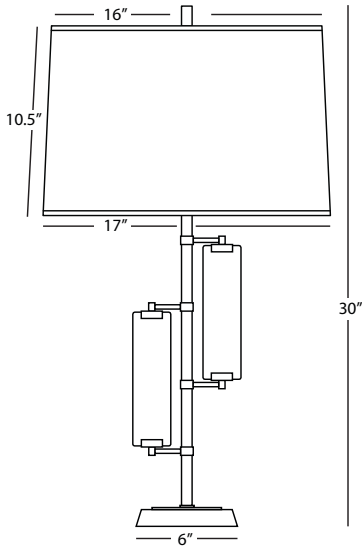
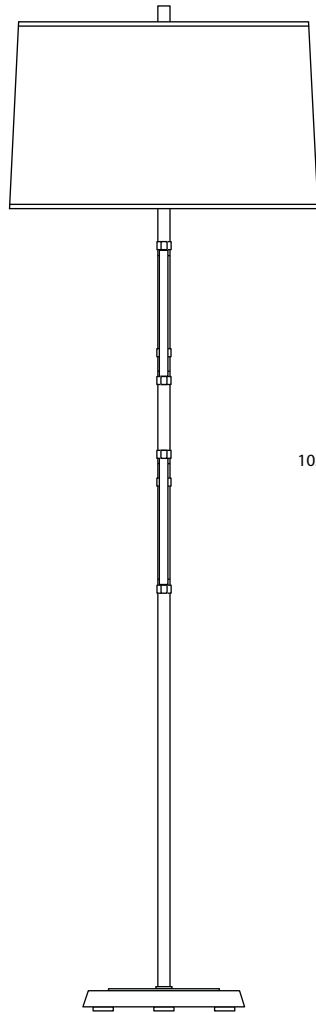

Alston

455
Table Lamp

1- 150W Max.
Bulb Type: A
Switch: Full Range Dimmer
Modern Brass Finish
Carrara Marble Accents
Oyster Linen Shade

FINISH OPTIONS:
S455 Polished Nickel



Z3318

Andre

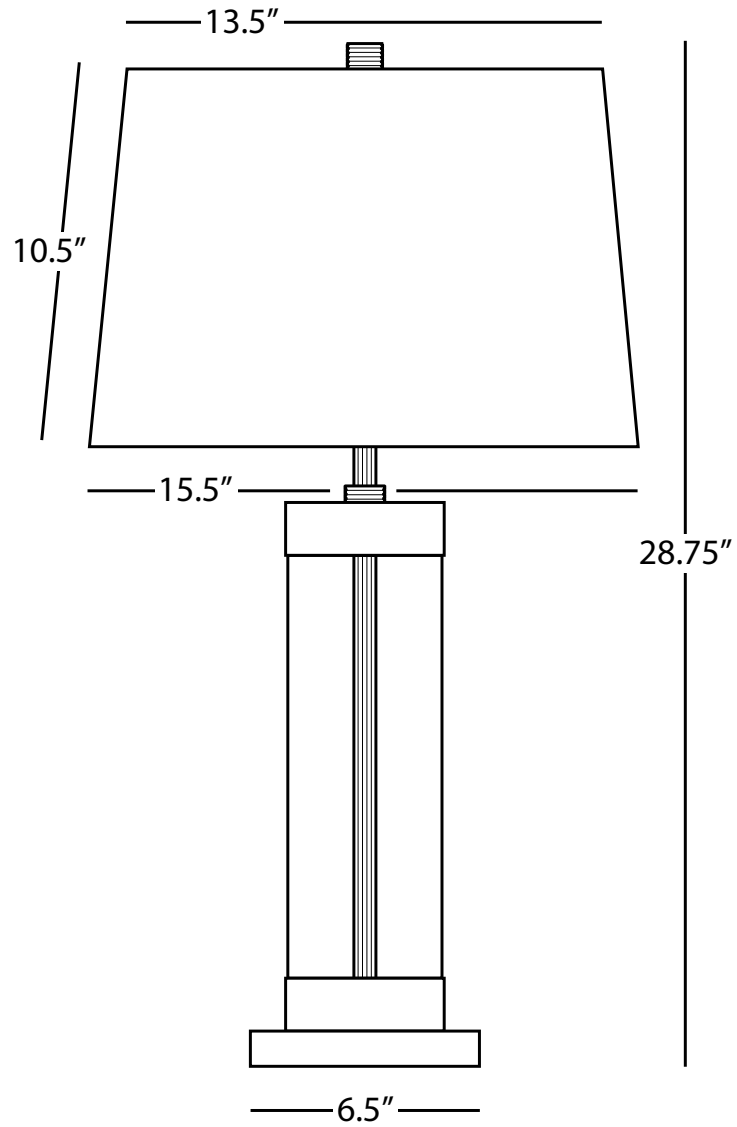

ANDRE

Z3318

Table Lamp

1 - 150W Max.
Bulb Type: A
Switch: Full Range Dimmer
Clear Glass Cylinder w/
Deep Patina Bronze Accents
Off-White Cotton Shade w/
Rolled Edge Hem



S165



167



S167



166

Andromeda

ANDROMEDA

167

Flush Mount/Wall Sconce

4 - 40W Max.
Bulb Type: G, Candelabra
Direct Wire
Modern Brass Finish
Clear Acrylic Rods w/ Matching Metal Tips

FINISH OPTION:
S167 Polished Nickel

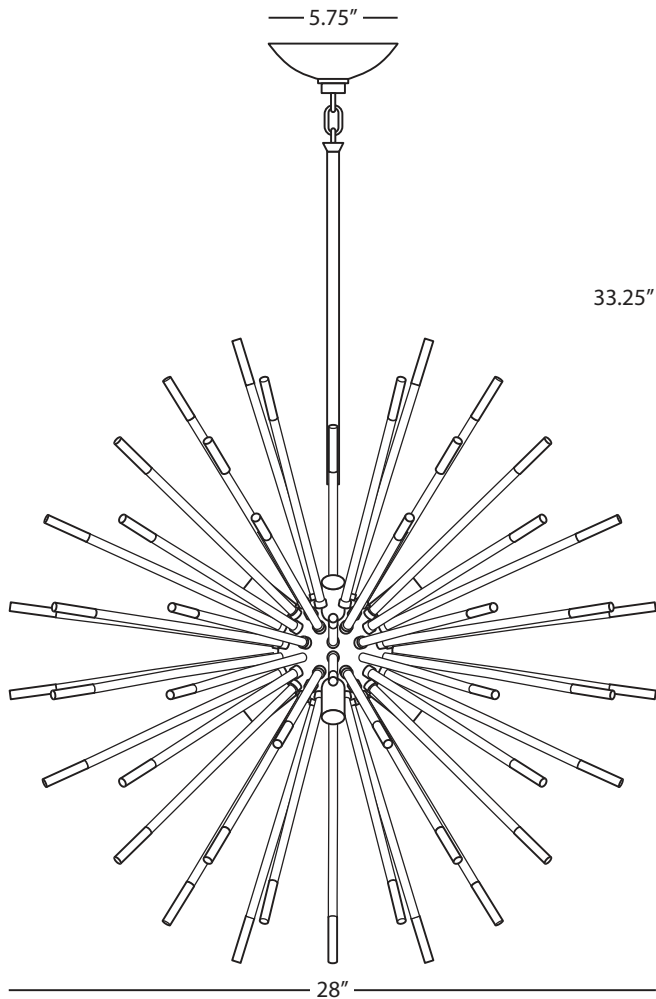
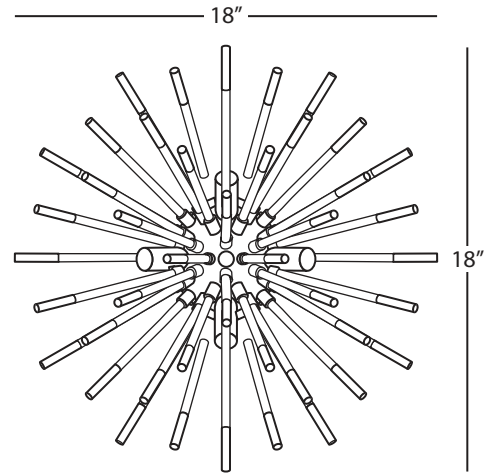
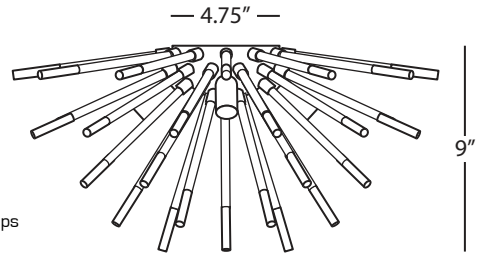

33.25" - 63.25" Adj.

28"

ANDROMEDA

166

Large Pendant

8 - 40W Max.
Bulb Type: G, Candelabra
Direct Wire
Modern Brass Finish
Clear Acrylic Rods w/ Matching Metal Tips
Susp. Hardware: 1 pc. 1/2" x 6" &
3 pcs. 1/2" x 12" Extensions

FINISH OPTION:
S166 Polished Nickel

ANDROMEDA

S165

Small Pendant

8 - 40W Max.
Bulb Type: G, Candelabra
Direct Wire
Polished Nickel Finish
Clear Acrylic Rods w/ Matching Metal Tips
Susp. Hardware: 1 pc. 1/2" x 6" &
3 pcs. 1/2" x 12" Extensions

FINISH OPTION:
165 Modern Brass

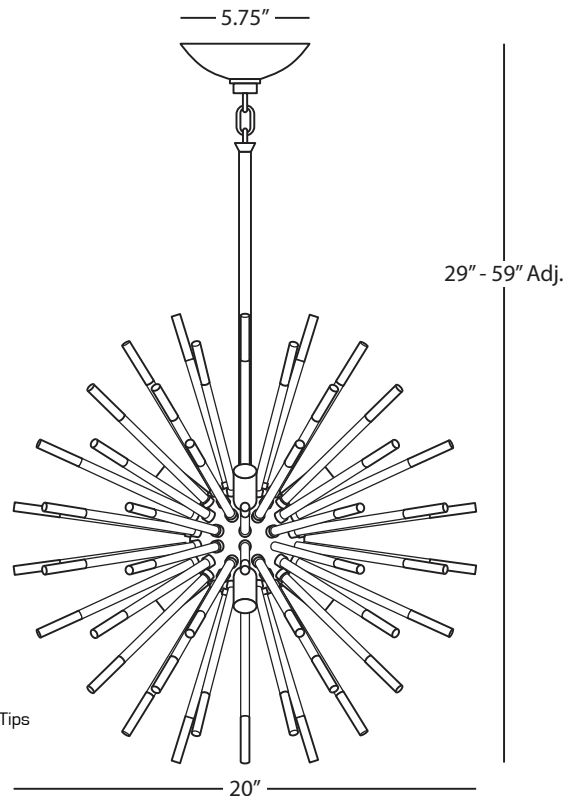

29" - 59" Adj.

20"



1200



1206



S1200

Andromeda

ANDROMEDA

1200

Oval Chandelier

8 - 40W Max.
 Bulb Type: G, Candelabra
 Direct Wire
 Modern Brass Finish
 Clear Acrylic Rods w/ Matching Metal Tips
 Susp. Hardware: 1 pc. 1/2" x 6" & 3 pcs. 1/2" x 12" Extensions

FINISH OPTION:

S1200 Polished Nickel

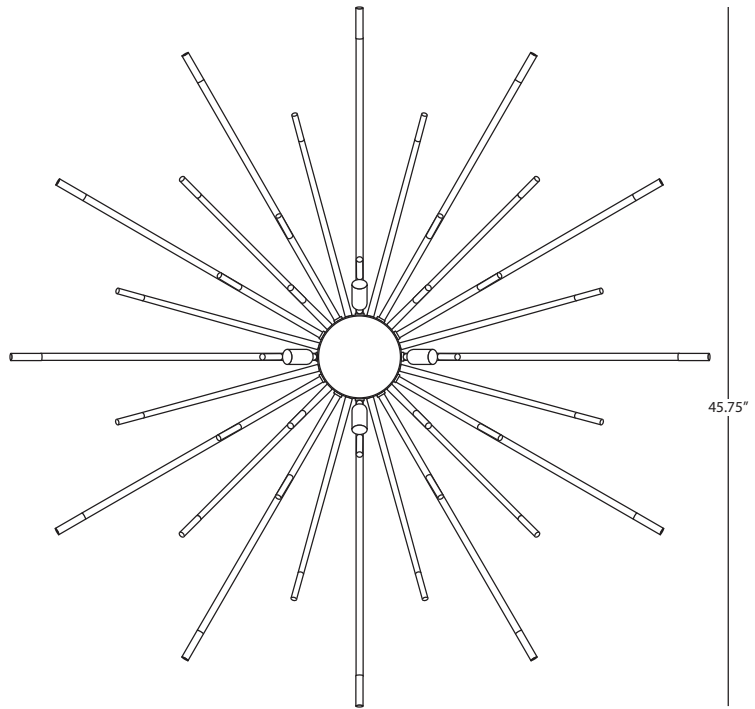

45.75"

45.75"

5.75"

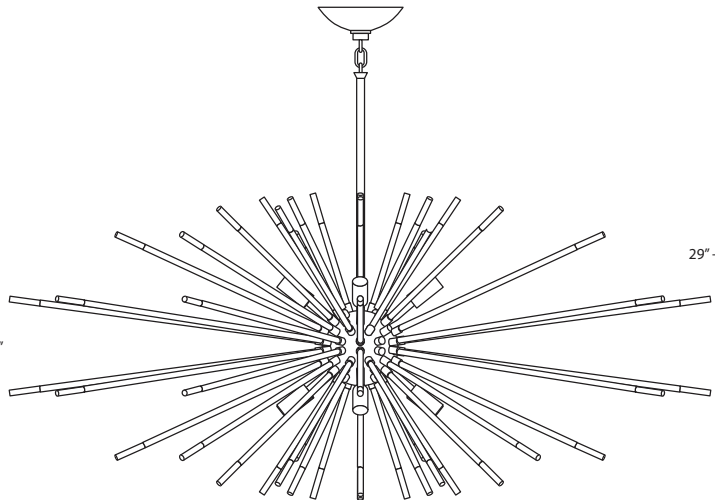

29" - 65" Adj.

20"

45.5" - 69.5" Adj.

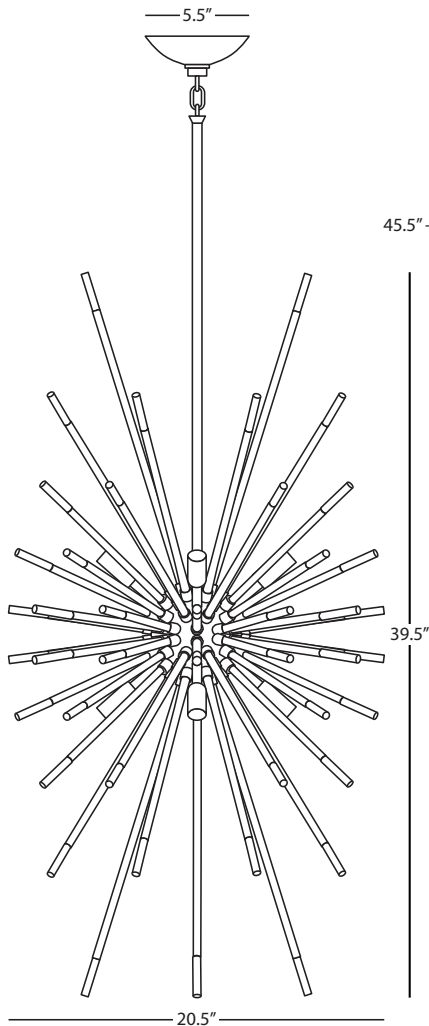

20.5"

39.5"

ANDROMEDA

1206

Vertical Chandelier

8 - 40W Max.
 Bulb Type: G, Candelabra Base
 Direct Wire
 Modern Brass Finish w/
 Clear Acrylic Rods with Matching Metal Tips
 Susp. Hardware: 1 pc. 1/2" x 6" & 3 pcs. 1/2" x 12" Extensions

FINISH OPTION:

S1206 Polished Nickel



S1305



S1305



S1306

Anemone

ANEMONE

S1305

Small Flush Mount/Wall Sconce

1 - 60W Max.
Bulb Type: A, Silver Tip
Direct Wire Only
Polished Nickel Finish

Ships with Silver Tip Bulb
[BUL01 See page 225]

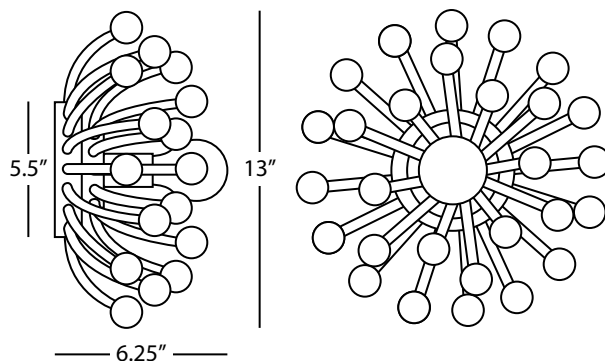

ANEMONE

S1306

Large Flush Mount/Wall Sconce

5 - 60W Max.
Bulb Type: A, Silver Tip
Direct Wire Only
Polished Nickel Finish

Ships with Five Historical Bulbs
[BUL01 (x5) See Page 225]

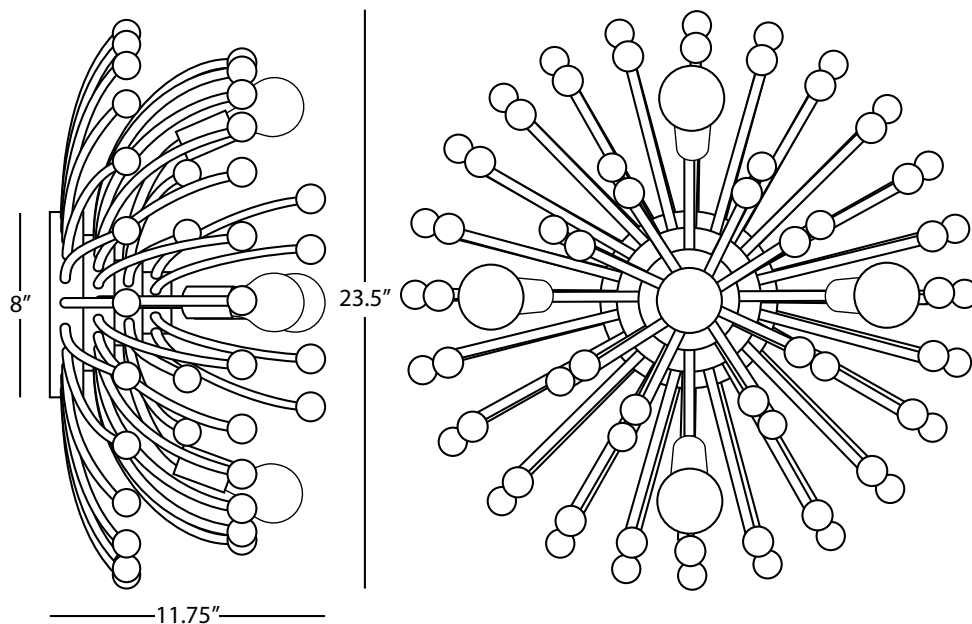



898



897

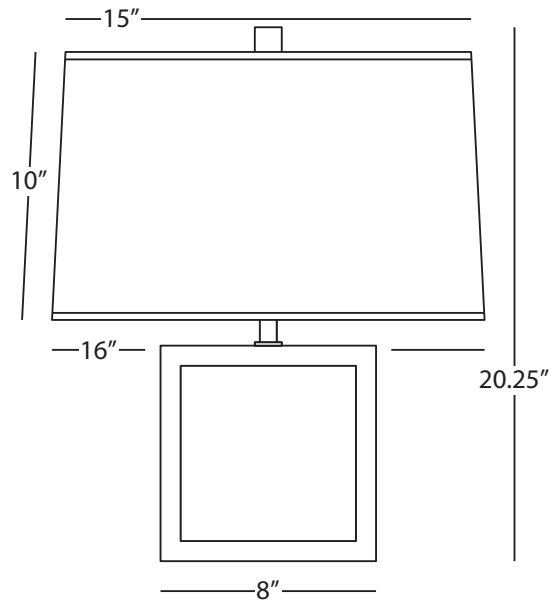
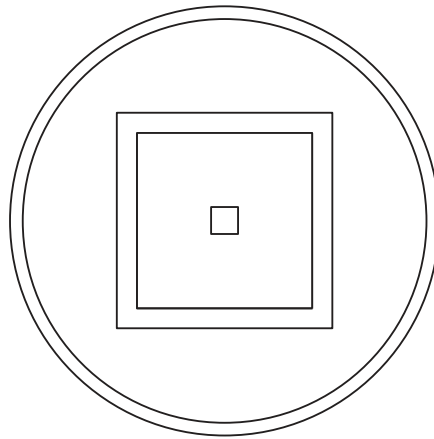

ANNA

897
Cube Table Lamp

1 - 150W Max.
Bulb Type: A
Switch: Hi-Lo Dimming
Faux Brown Snakeskin Wrapped Base
w/ Aged Brass Accents
Taupe Dupioni Fabric Shade w/
Self-Fabric Top Diffuser

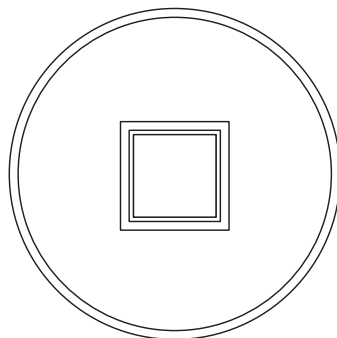
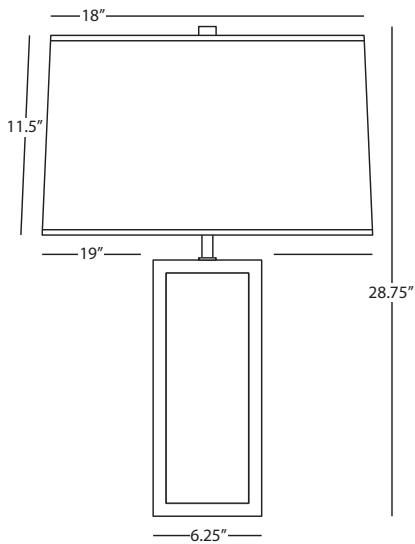

ANNA

898
Rectangular Table Lamp

1 - 150W Max.
Bulb Type: A
Switch: Hi-Lo Dimming
Faux Brown Snakeskin Wrapped Base w/
Aged Brass Accents
Taupe Pearl Dupioni Fabric Shade



2506X



2605



2504



2604X



2501



2503X



2600

MARY MCDONALD ANNIKA

2506X

Accent Lamp

1 - 60W Max.
 Bulb Type: B, Candelabra
 Switch: On-Off Line Switch
 Chocolate Lacquered Paint w/
 Natural Brass & Ivory Crackle Accents
 Cloud Cream Silk Shade

FINISH/SHADE OPTIONS:

- 2504** Cobalt Lacquered Paint
Cobalt Painted Parchment Shade
- 2504X** Cobalt Lacquered Paint
Cloud Cream Silk Shade
- 2505** Red Lacquered Paint
Red Painted Parchment Shade
- 2505X** Red Lacquered Paint
Cloud Cream Silk Shade
- 2506** Chocolate Lacquered Paint
Chocolate Painted Parchment Shade
- 2507** Black Lacquered Paint
Black Painted Parchment Shade
- 2507X** Black Lacquered Paint
Cloud Cream Silk Shade
- 2603** Tangerine Lacquered Paint
Tangerine Painted Parchment Shade
- 2603X** Tangerine Lacquered Paint
Cloud Cream Silk Shade
- 2604** Ivory Lacquered Paint
Ivory Painted Parchment Shade
- 2604X** Ivory Lacquered Paint
Cloud Cream Silk Shade
- 2605** Blush Lacquered Paint
Blush Painted Parchment Shade
- 2605X** Blush Lacquered Paint
Cloud Cream Silk Shade

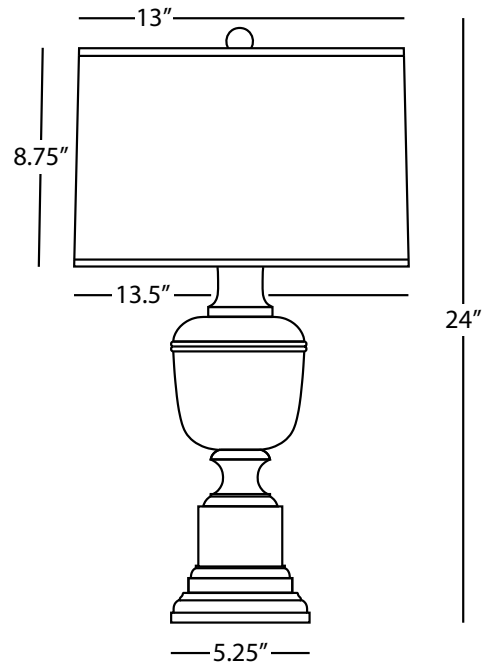

MARY MCDONALD ANNIKA

2501

Table Lamp

1 - 150W Max.
 Bulb Type: A
 Switch: 3-Way
 Red Lacquered Paint w/
 Natural Brass & Ivory Crackle Accents
 Red Painted Opaque Parchment Shade w/ Matte Gold Lining

FINISH/SHADE OPTIONS:

- 2500** Cobalt Lacquered Paint
Cobalt Painted Parchment Shade
- 2500X** Cobalt Lacquered Paint
Cloud Cream Silk Shade
- 2501X** Red Lacquered Paint
Cloud Cream Silk Shade
- 2502** Chocolate Lacquered Paint
Chocolate Painted Parchment Shade
- 2502X** Chocolate Lacquered Paint
Cloud Cream Silk Shade
- 2503** Black Lacquered Paint
Black Painted Parchment Shade
- 2503X** Black Lacquered Paint
Cloud Cream Silk Shade
- 2600** Tangerine Lacquered Paint
Tangerine Painted Parchment Shade
- 2600X** Tangerine Lacquered Paint
Cloud Cream Silk Shade
- 2601** Ivory Lacquered Paint
Ivory Painted Parchment Shade
- 2601X** Ivory Lacquered Paint
Cloud Cream Silk Shade
- 2602** Blush Lacquered Paint
Blush Painted Parchment Shade
- 2602X** Blush Lacquered Paint
Cloud Cream Silk Shade

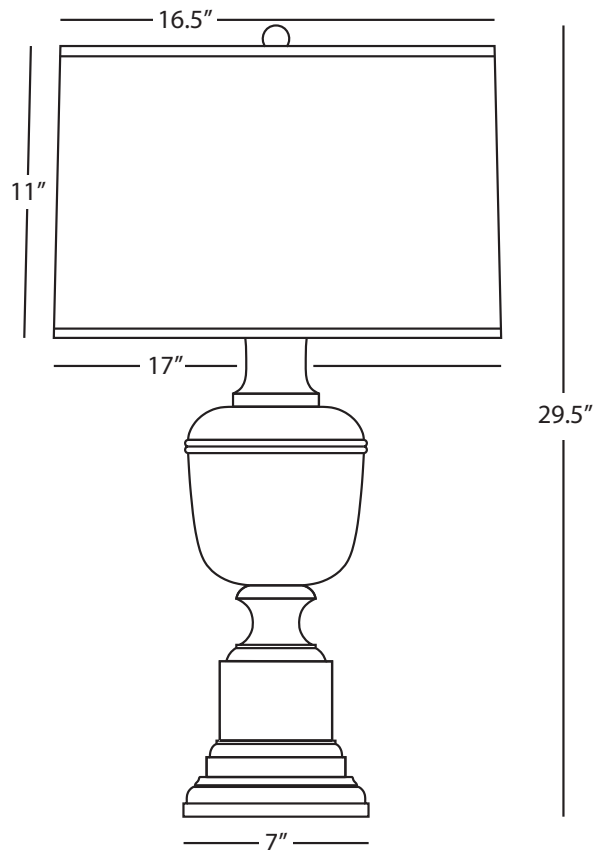



1582

Apollo

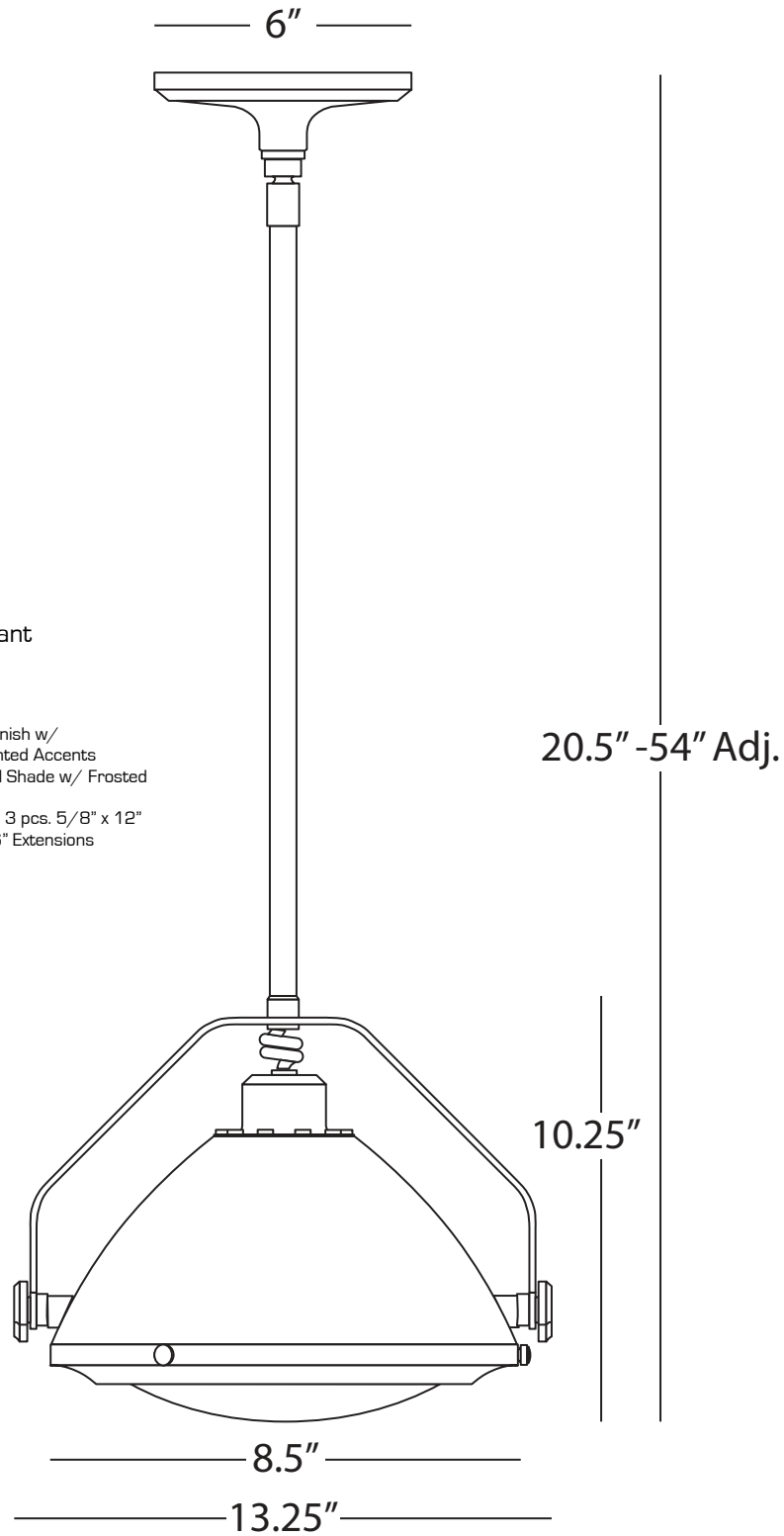



S2286



2287

Archer

ARCHER

2287 Small Floor Lamp

2 - 100W Max.
Bulb Type: A
Switch: Full Range Dimmer Foot Switch
Warm Brass Finish
Carrara Marble Base
White Brussels Linen Shade w/
Self-Fabric Bottom Diffuser

FINISH OPTION:
S2287 Polished Nickel

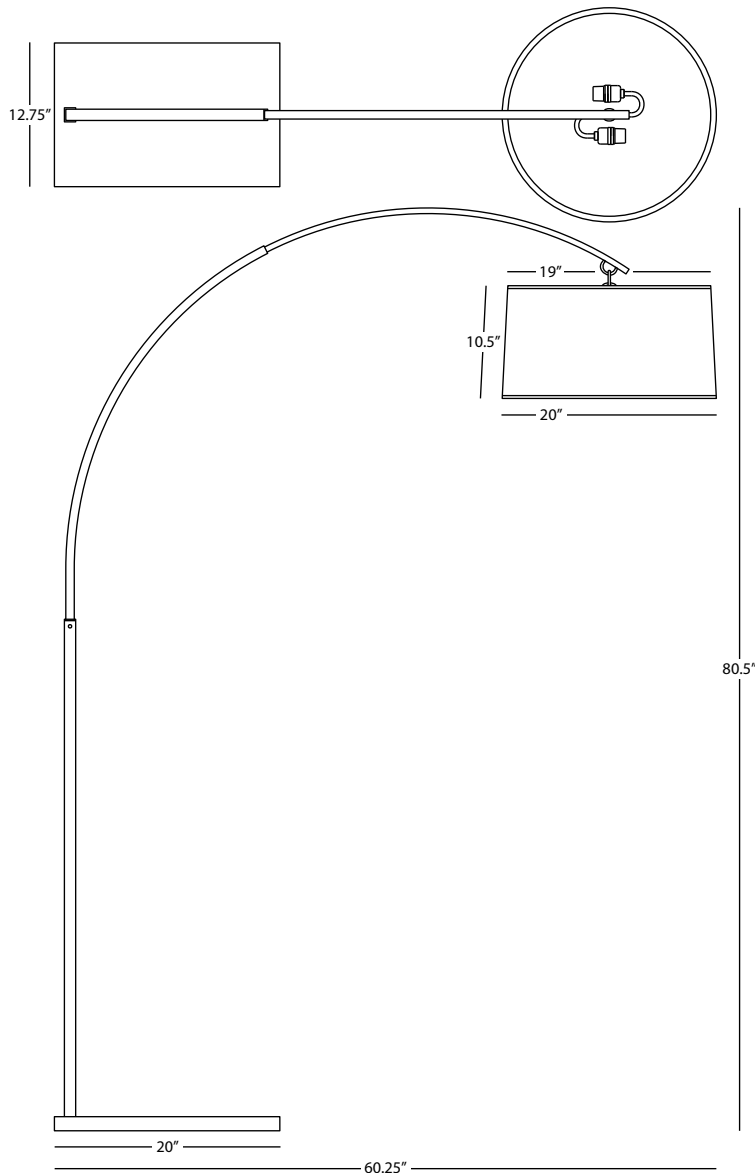
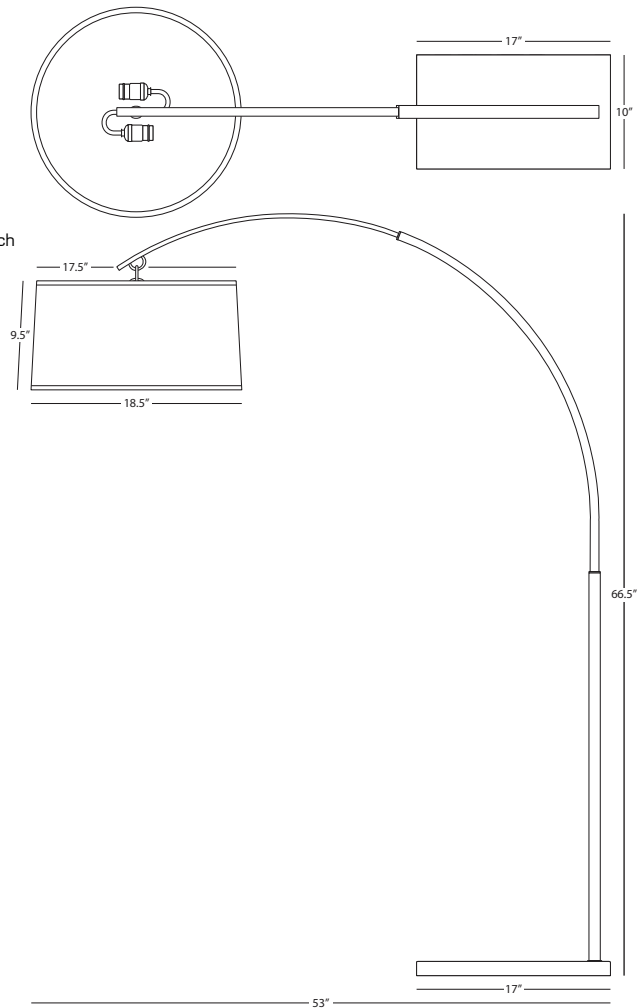

ARCHER

S2286 Floor Lamp

2 - 150W Max.
Bulb Type: A
Switch: Full Range Dimmer Foot Switch
Polished Nickel Finish
Carrara Marble Base
White Brussels Linen Shade w/
Self-Fabric Bottom Diffuser

FINISH OPTION:
2286 Warm Brass



3329



3324W



3324B

Artemis

ARTEMIS

3329 Accent Lamp

1 - 60W Max.
Bulb Type: B11 Torpedo
Switch: Full Range Dimmer
Clear Lead Crystal w/ Silver Plate Accents
Rectangular Cafe Dupioni Silk Shade

SHADE OPTIONS:
3329B Black Dupioni Silk
3329W Off-White Dupioni Silk

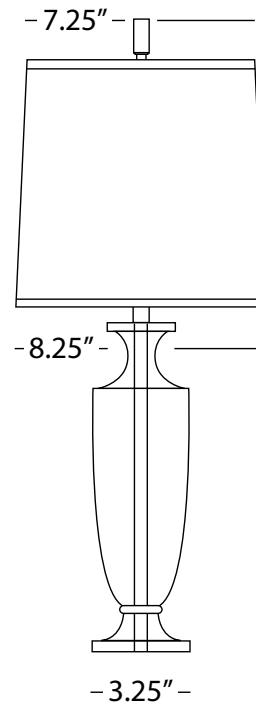
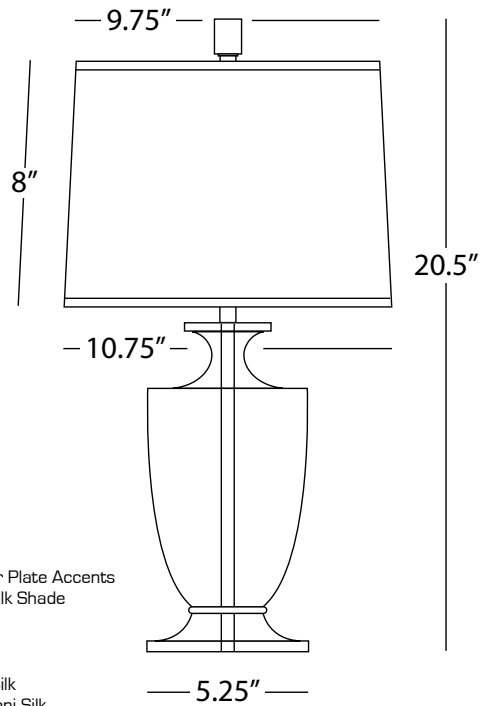

ARTEMIS

3324W Table Lamp

1 - 150W Max.
Bulb Type: A
Switch: Full Range Dimmer
Clear Lead Crystal w/ Silver Plate Accents
Rectangular Off-White Dupioni Silk Shade

SHADE OPTIONS:
3324 Cafe Dupioni Silk
3324B Black Dupioni Silk

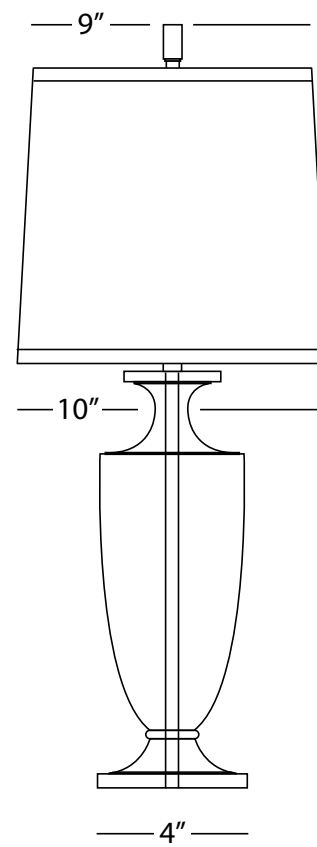
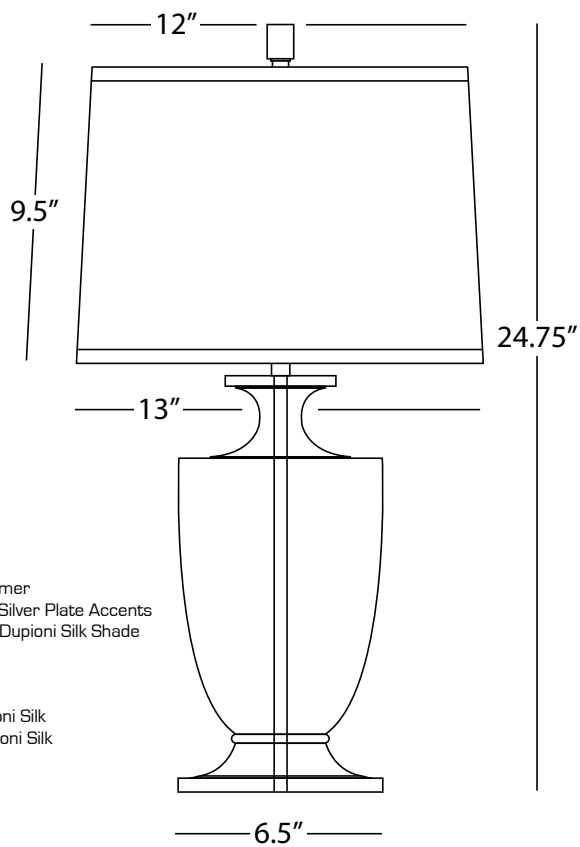

Arthur



Arthur



[Click photo above to watch Arthur video](#)

A modern take on classic candlestick designs, Arthur features tiered tapers and subtle curves that create a timeless and unique look to enhance your space.



S1225



1225



Z1225

Arthur

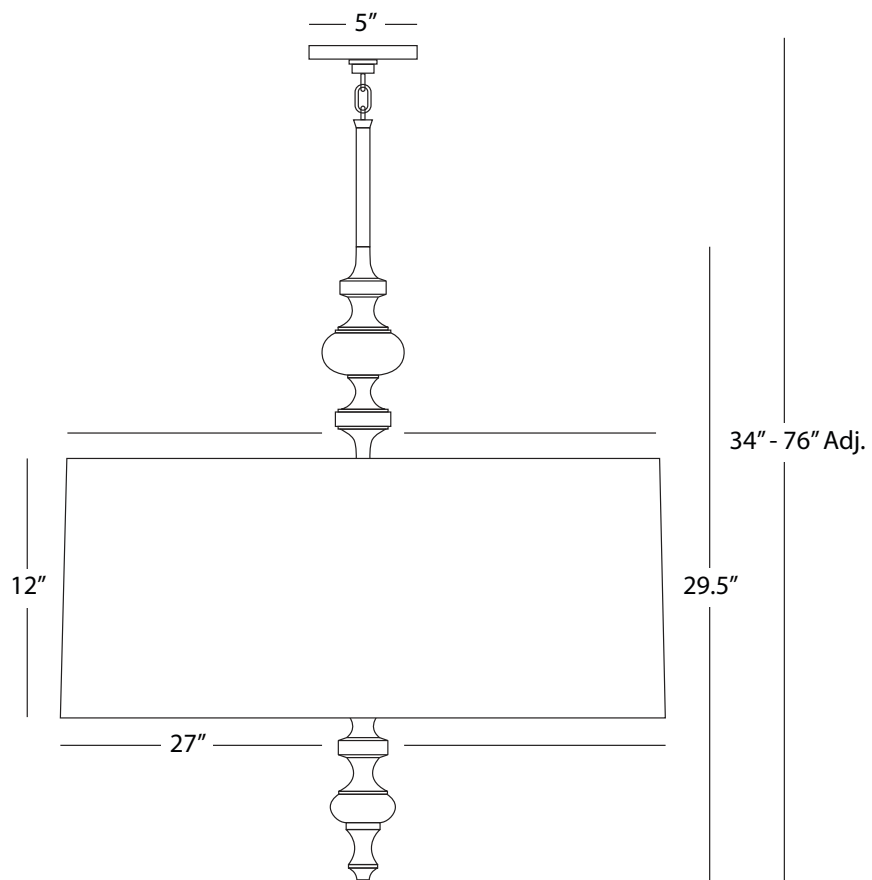

ARTHUR

S1225 Pendant

3 - 100W Max.
Bulb Type: A
Direct Wire Only
Polished Nickel Finish
Pearl Dupioni Fabric Shade with Self-Fabric Diffuser

FINISH OPTIONS:

1225 Modern Brass
Z1225 Deep Patina Bronze

Arthur



Arthur



[Click photo above to watch Arthur video](#)

A modern take on classic candlestick designs, Arthur features tiered tapers and subtle curves that create a timeless and unique look to enhance your space.



Z1224



S1224



1224

Arthur

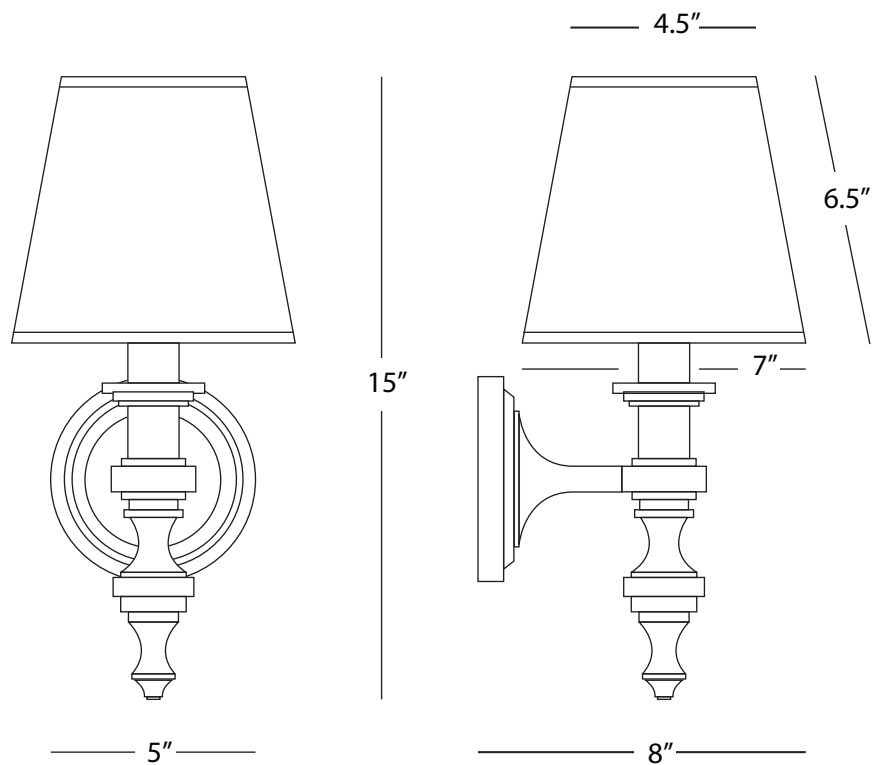

ARTHUR

Z1224

Wall Sconce

1 - 60W Max.
Bulb Type: B, Candelabra Base
Switch: On-Off Line Switch
24" Cord Cover/Direct Wire
Deep Patina Bronze Finish
Pearl Dupioni Fabric Shade

FINISH OPTIONS:

1224 Modern Brass
S1224 Polished Nickel

Arthur



Z1221



S1223



1220

Arthur



[Click photo above to watch Arthur video](#)

A modern take on classic candlestick designs, Arthur features tiered tapers and subtle curves that create a timeless and unique look to enhance your space.



Z1221



S1223



1220

Arthur

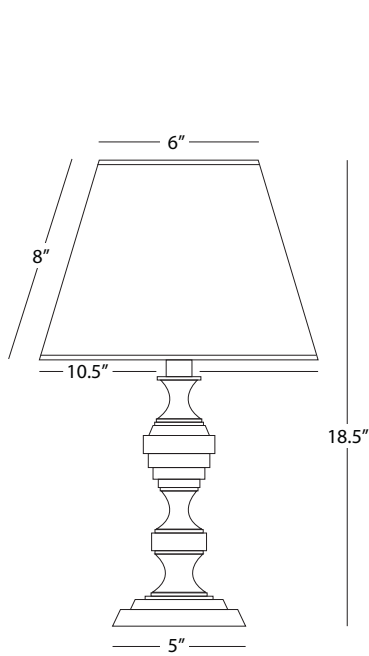

ARTHUR

Z1221

Accent Lamp

1 - 100W Max.
 Bulb Type: A
 Switch: Full Range Dimmer Line Switch
 Deep Patina Bronze Finish
 Pearl Dupioni Fabric Shade

FINISH OPTIONS:
1221 Modern Brass
S1221 Polished Nickel

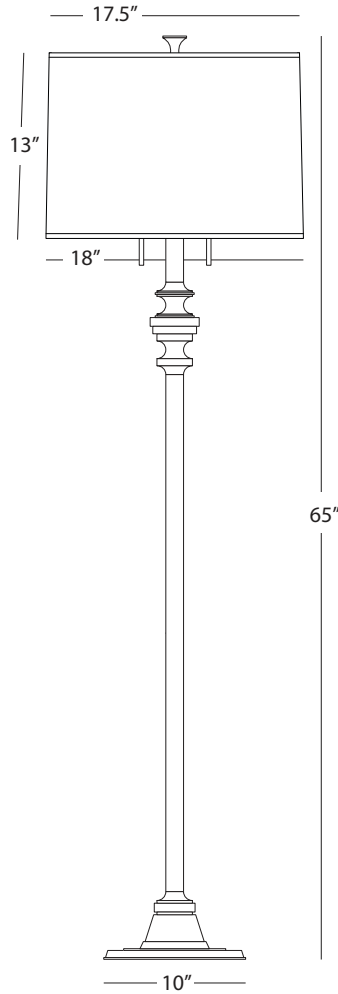

ARTHUR

1223

Floor Lamp

2 - 100W Max.
 Bulb Type: A
 Switch: On-Off Pull Chain
 Modern Brass Finish
 Pearl Dupioni Fabric Shade

FINISH OPTIONS:
S1223 Polished Nickel
Z1223 Deep Patina Bronze

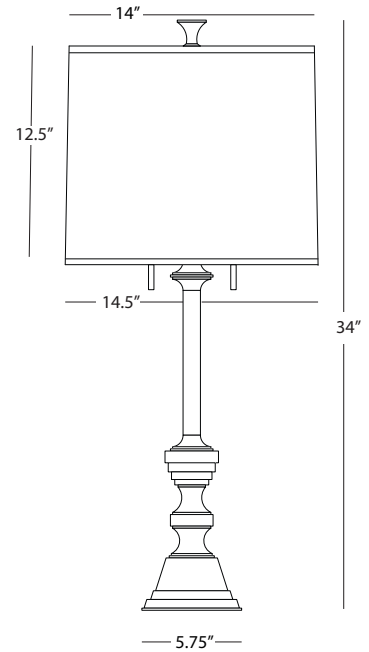

ARTHUR

1220

Table Lamp

1 - 150W Max.
 Bulb Type: A
 Switch: On-Off Pull Chain
 Modern Brass Finish
 Pearl Dupioni Fabric Shade

FINISH OPTIONS:
S1220 Polished Nickel
Z1220 Deep Patina Bronze



ML992



BN992



PC992



EG992



CI992



CR992

Athena

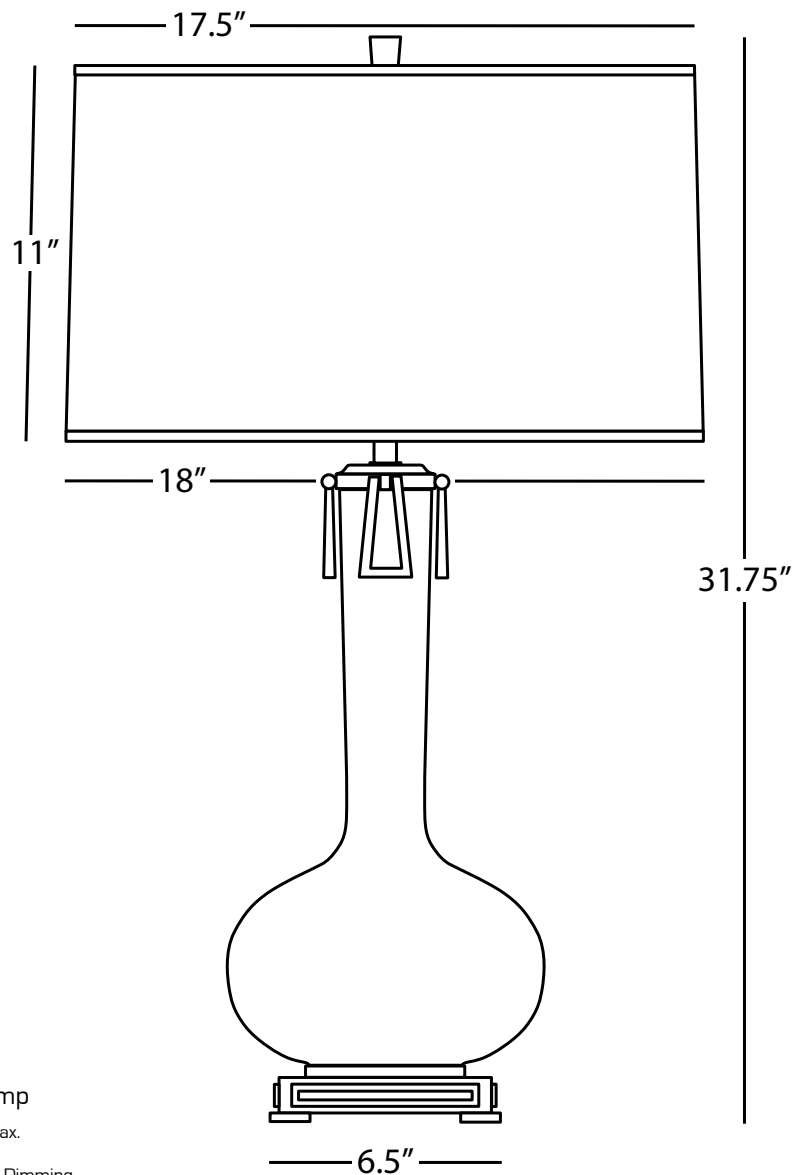

ATHENA

CI992

Table Lamp

1 - 150W Max.

Bulb Type: A

Switch: Hi-Lo Dimming

Citron Glazed Ceramic

Cast Metal Base and Ring Details

Aged Brass Finish

Open Weave Heather Linen Shade

See Page 495 for Color Options



LY980



ST980



PC980



MB980



MR980

Audrey

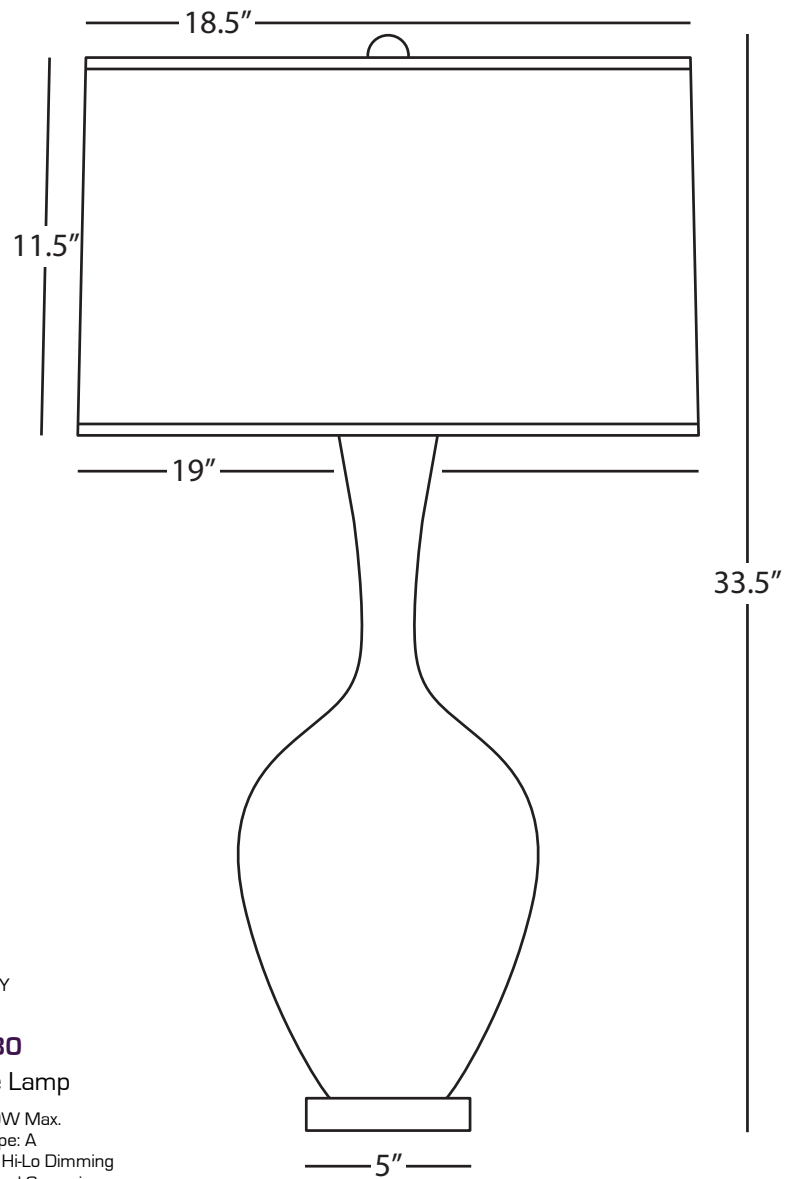

AUDREY

LY980

Table Lamp

1 - 150W Max.
Bulb Type: A
Switch: Hi-Lo Dimming
Lily Glazed Ceramic
Lucite Base
Fondine Fabric Shade

See Page 495 for Color Options



3390



B3390



S3390

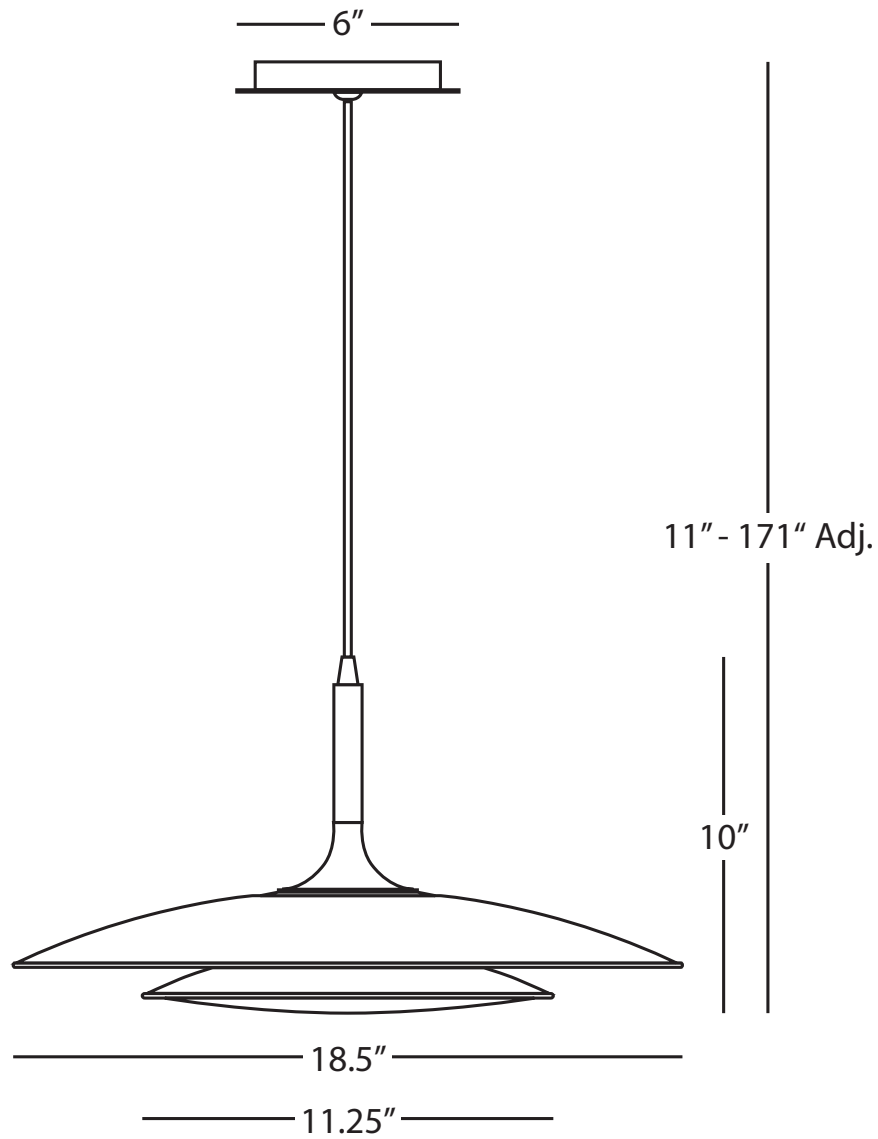

AXIOM

3390

Pendant

3 - 35W Max.
Bulb Type: 120V G6.35 Bi-Pin Halogen
Bulbs Included
Direct Wire
Polished Gold Finish
Frosted, White Cased Glass Diffuser
Susp. Hardware: 160" Black Fabric
Wrapped Cord

FINISH OPTIONS:

B3390 Gloss Black
S3390 Polished Nickel



2134



2136

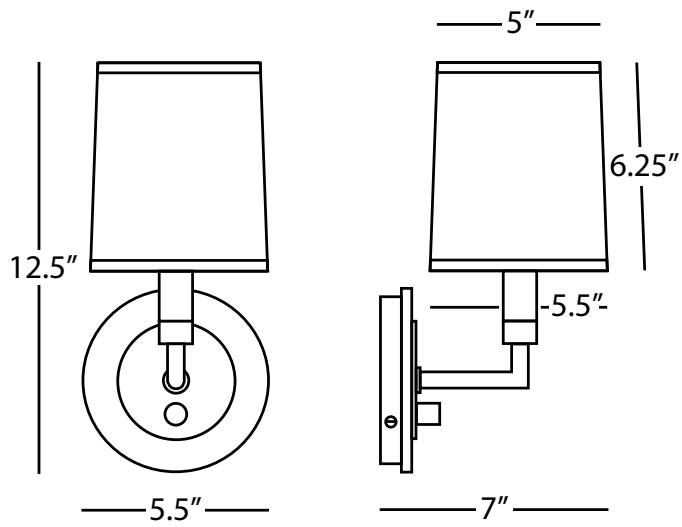

AXIS

2136
Single Sconce

1 - 60W Max.
Bulb Type: B, Candelabra
Switch: On-Off
24" Cord Cover/Direct Wire
Aged Brass Finish w/
Cocoa Brown Accents
Honed Travertine Back Plate
Fondine Fabric Shade w/
Black Contrasting Trim

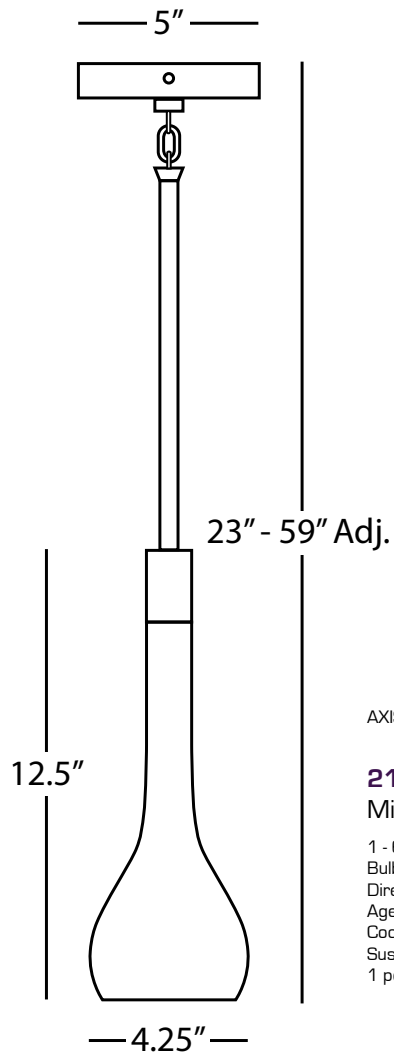

AXIS

2134
Mini Pendant

1 - 60W Max.
Bulb Type: G16.5 Candelabra
Direct Wire Only
Aged Brass Finish w/
Cocoa Brown Accents
Susp. Hardware: 3 pcs. 1/2" x 12" &
1 pc. 1/2" x 6" Extensions



D2139



2200



D2201

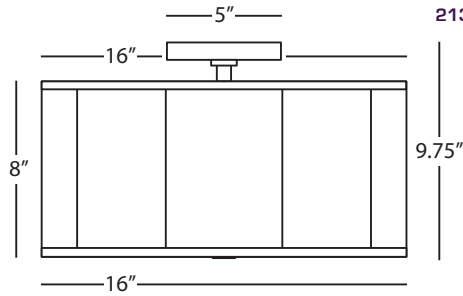
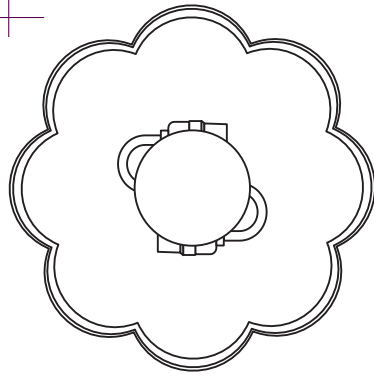

AXIS

D2139
16" Semi-Flush Mount

2 - 100W Max.
Bulb Type: A
Direct Wire
Blackened Antique Nickel Finish
Scalloped Ascot White Fabric Shade w/
Black Contrasting Trim
15" Dia. White Acrylic Diffuser

FINISH/SHADE OPTION:
2139 Aged Brass
Fondine Shade w/
Black Contrasting Trim

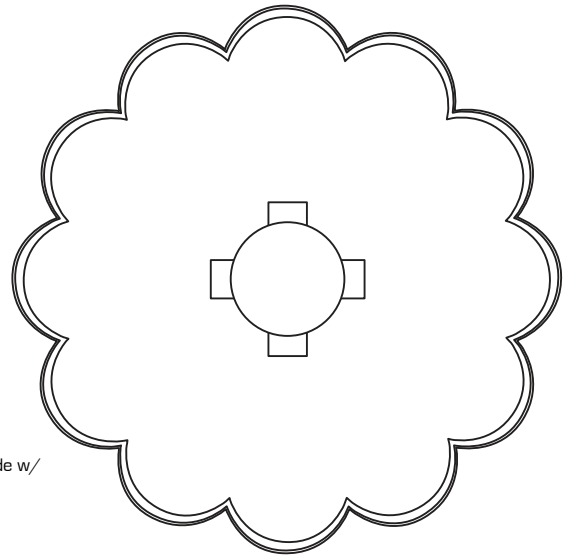

AXIS

D2201
24" Semi-Flush Mount

4 - 100W Max.
Bulb Type: A
Direct Wire
Blackened Antique Nickel Finish
Scalloped Ascot White Fabric Shade w/
Black Contrasting Trim
23" Dia. White Acrylic Diffuser

FINISH/SHADE OPTION:
2201 Aged Brass
Fondine Shade w/
Black Contrasting Trim

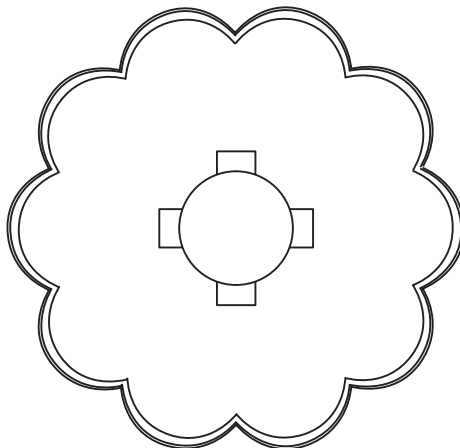
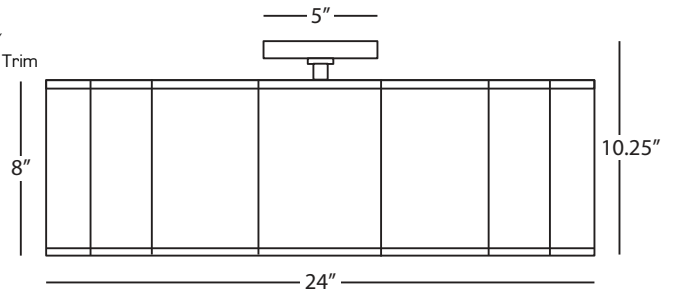
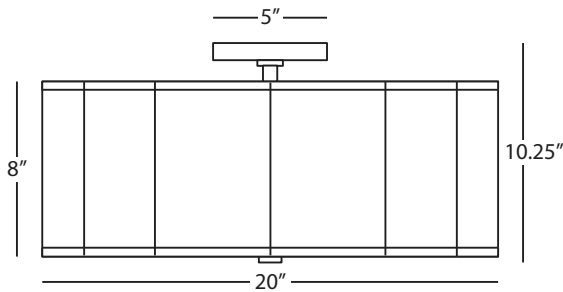

AXIS

D2200
20" Semi-Flush Mount

4 - 100W Max.
Bulb Type: A
Direct Wire
Aged Brass Finish
Scalloped Fondine Fabric Shade w/
Black Contrasting Trim
19" Dia. White Acrylic Diffuser

FINISH/SHADE OPTION:
D2200 Blackened Antique Nickel
Ascot White Fabric w/
Black Contrasting Trim



Z348



S349



Z347

Bandit

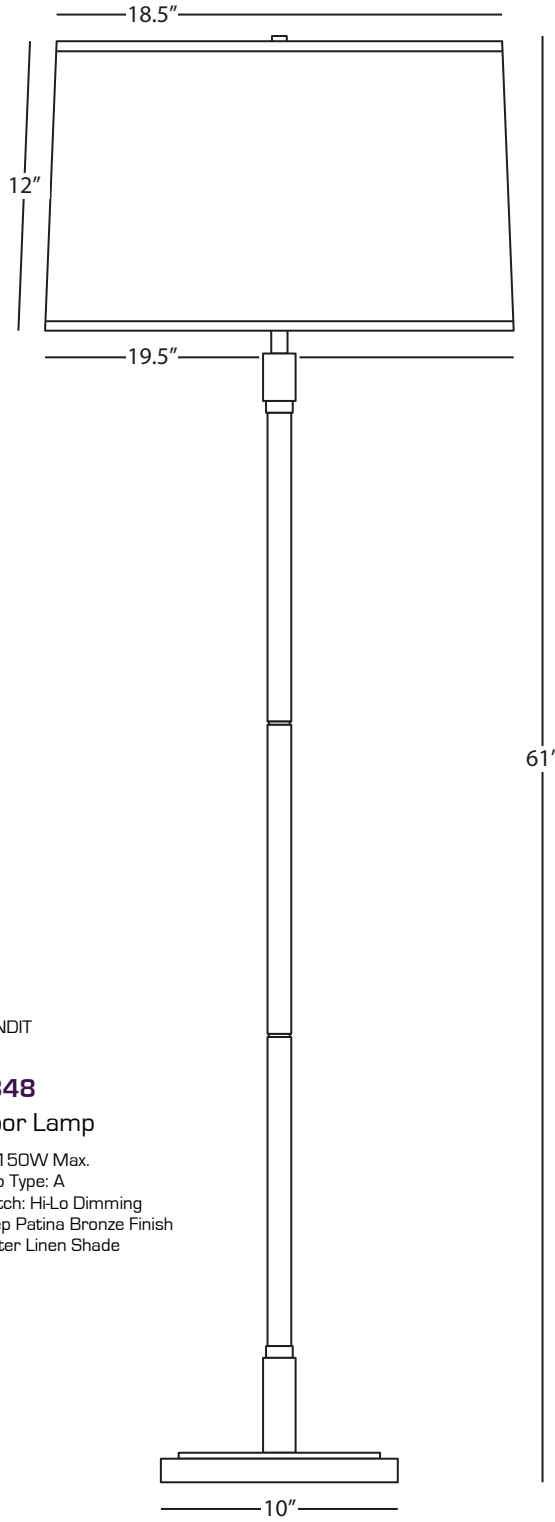

BANDIT

Z348

Floor Lamp

1 - 150W Max.
 Bulb Type: A
 Switch: Hi-Lo Dimming
 Deep Patina Bronze Finish
 Oyster Linen Shade

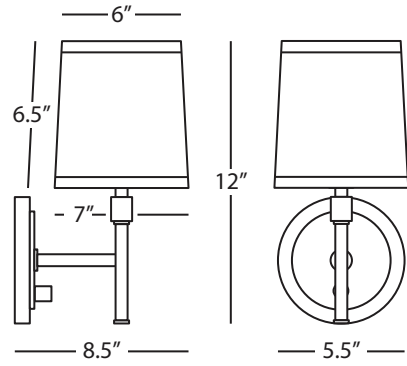

BANDIT

S349

Wall Sconce

1 - 60W Max.
 Bulb Type: B, Candelabra
 Switch: Hi-Lo Dimming
 24" Cord Cover/Direct Wire
 Polished Nickel Finish
 Oyster Linen Shade

FINISH OPTION:

Z349 Deep Patina Bronze

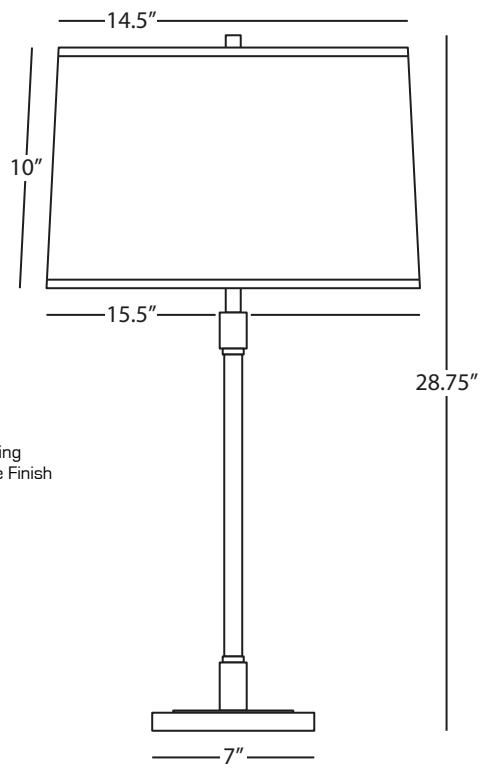

BANDIT

Z347

Table Lamp

1 - 150W Max.
 Bulb Type: A
 Switch: Hi-Lo Dimming
 Deep Patina Bronze Finish
 Oyster Linen Shade



9824BRN



9857X



9867B



9866



9856

Beaux Arts

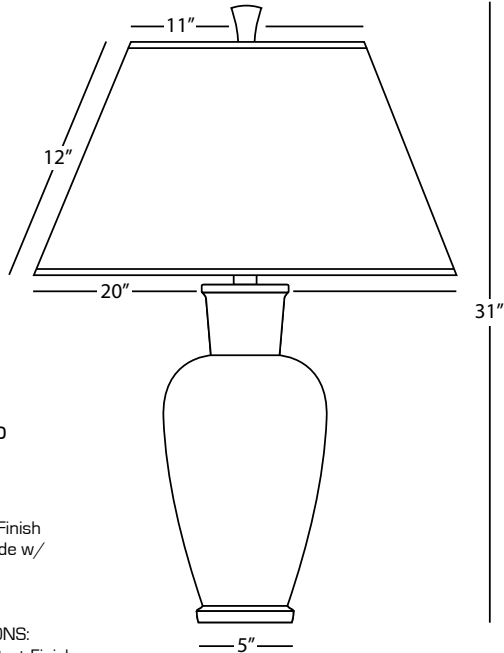

BEAUX ARTS

9867B Urn Table Lamp

1 - 150W Max.
Bulb Type: A
Switch: 3-Way
Dark Antique Copper Finish
Black Parchment Shade w/
Matte Gold Lining

FINISH/SHADE OPTIONS:

- 9857** Antique Rust Finish
 Golden Saki Fabric
- 9857X** Antique Rust Finish
 Translucent Flax Parchment
- 9867** Dark Antique Copper Finish
 Oyster Linen

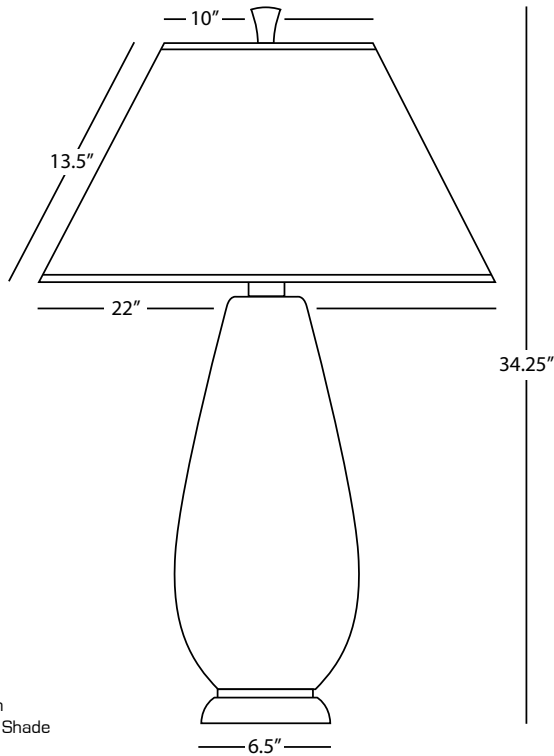

BEAUX ARTS

9856 Table Lamp

1 - 150W Max.
Bulb Type: A
Switch: 3-Way
Antique Rust Finish
Golden Saki Fabric Shade

FINISH/SHADE OPTIONS:

- 9856X** Antique Rust Finish
 Translucent Flax Parchment
- 9866** Dark Antique Copper Finish
 Oyster Linen
- 9866B** Dark Antique Copper Finish
 Black Parchment w/
 Matte Gold Lining

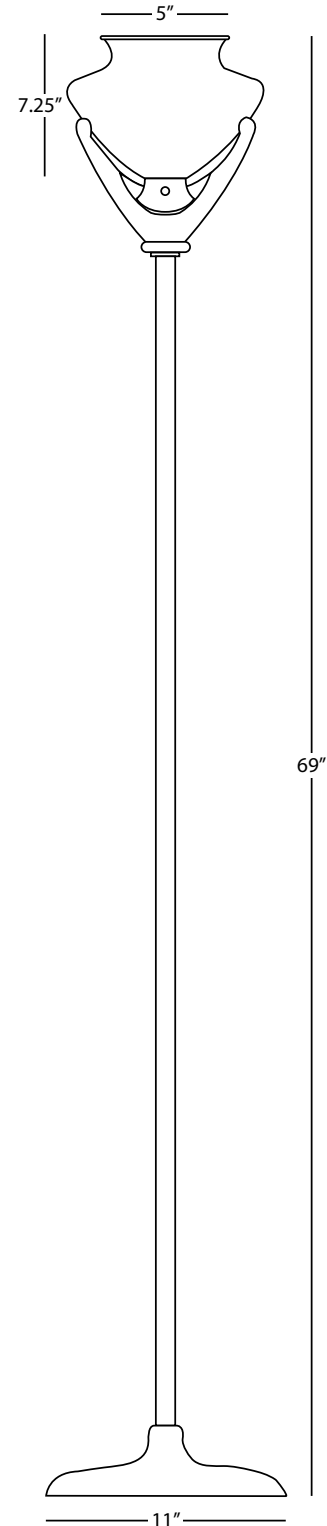

BEAUX ARTS

9824BRN Floor Torchiera

1 - 150W Max.
Bulb Type: A
Switch: 3-Way
Antiqued Rust Finish
Frosted, Amber Seeded Glass Shade



N616

Beehive

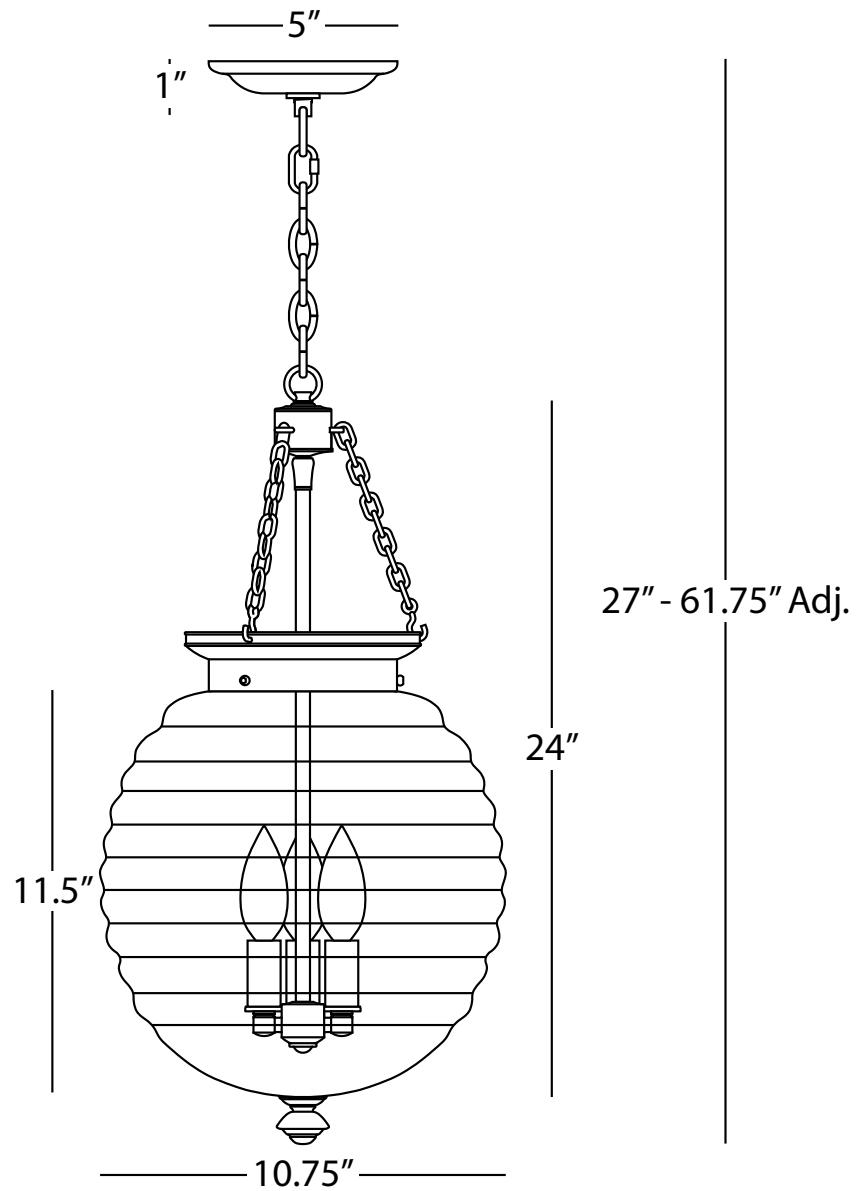

BEEHIVE

N616 Pendant

3 - 60W Max.
Bulb Type: B11 Torpedo
Direct Wire Only
Polished Nickel Finish
Clear Glass Shade
Susp. Hardware: 3 Ft. Chain

| Belvedere



Belvedere

[Click photo above to watch Belvedere Table Lamp video](#)

The Belvedere collection takes a classic urn shape and brings it to the next level with gorgeous curves and graceful tapers that create a sophisticated and timeless design.



1370



S1370

Belvedere

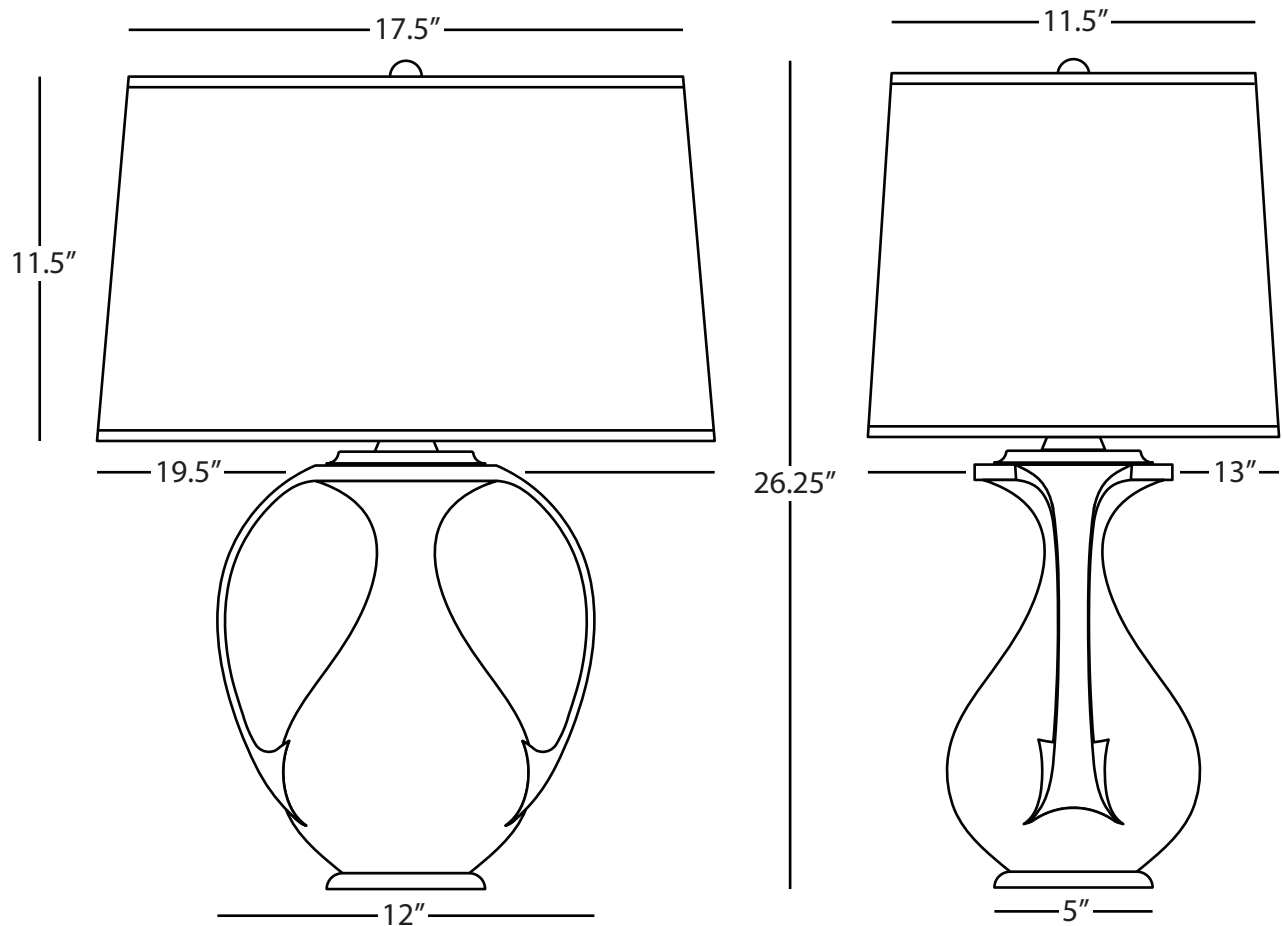

BELVEDERE

S1370

Urn Table Lamp

1 - 150W Max.

Bulb Type: A

Switch: Full Range Dimmer

Polished Nickel Finish

Pearl Dupioni Fabric Shade

FINISH OPTIONS:

1370 Modern Brass

Z1370 Deep Patina Bronze



1006



S1002

Bling

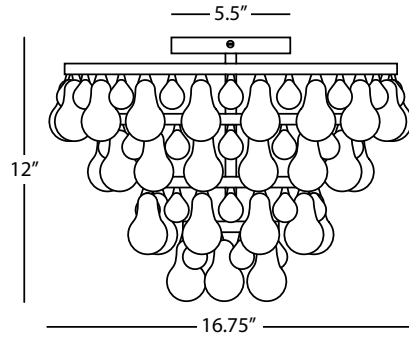

BLING

S1002 Flush Mount

2 - 60W Max.
Bulb Type: B, Medium Base
Direct Wire
Polished Nickel Finish
Glass Drops

FINISH OPTIONS:

1002 Antique Brass
Z1002 Deep Patina Bronze

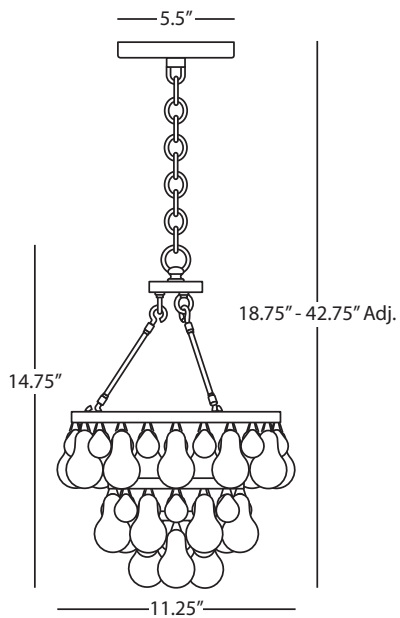

BLING

1006 Small Pendant

2 - 60W Max.
Bulb Type: G16.5 Candelabra
Direct Wire
Antique Brass Finish
Glass Drops
Susp. Hardware: 3 Ft. Chain

FINISH OPTIONS:

S1006 Polished Nickel



1000



1004



S1007

BLING

1000

Chandelier w/Convertible Double Canopy*

4 - 60W Max.
 Bulb Type: B, Medium Base
 Direct Wire Only
 Antique Brass Finish
 Glass Drops
 Susp. Hardware: 3 Ft. Chain

FINISH OPTIONS:

S1000 Polished Nickel
Z1000 Deep Patina Bronze

*Can be converted to a semi-flush mount by mounting the center canopy directly to ceiling canopy

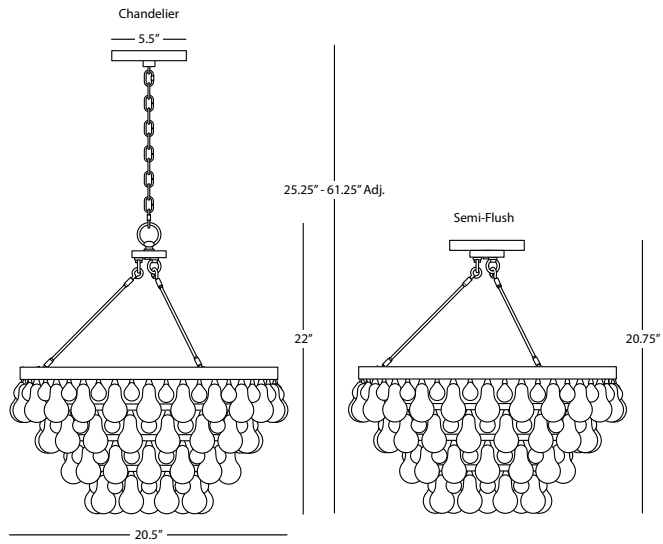

BLING

1004

Large Chandelier

6 - 100W Max.
 Bulb Type: A
 Direct Wire
 Antique Brass Finish
 Glass Drops
 Susp. Hardware: 3 Ft. Chain

FINISH OPTIONS:

S1004 Polished Nickel
Z1004 Deep Patina Bronze

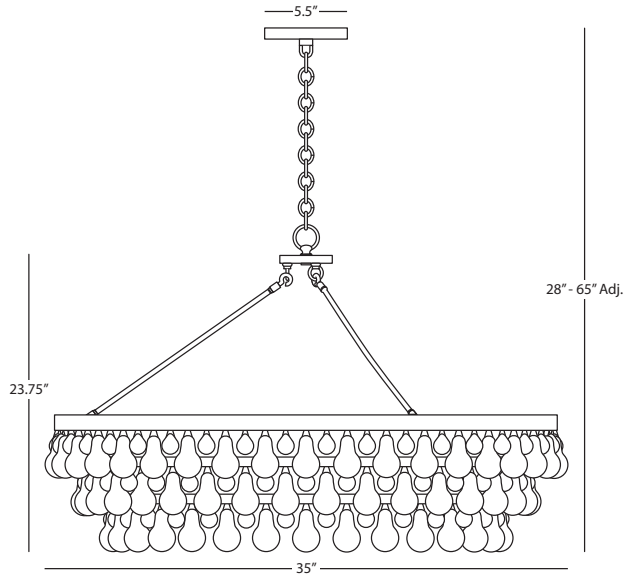

BLING

S1007

Oval Chandelier

8 - 60W Max.
 Bulb Type: A
 Direct Wire
 Polished Nickel Finish
 Glass Drops
 Susp. Hardware: 2 pcs. 5/8" x 6"
 & 6 pcs. 5/8" x 12" Extensions

FINISH OPTIONS:

1007 Antique Brass
Z1007 Deep Patina Bronze

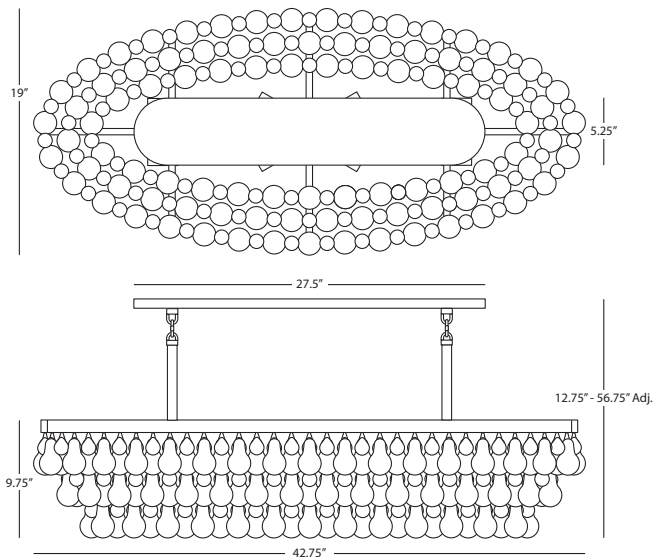



WH579



BK579

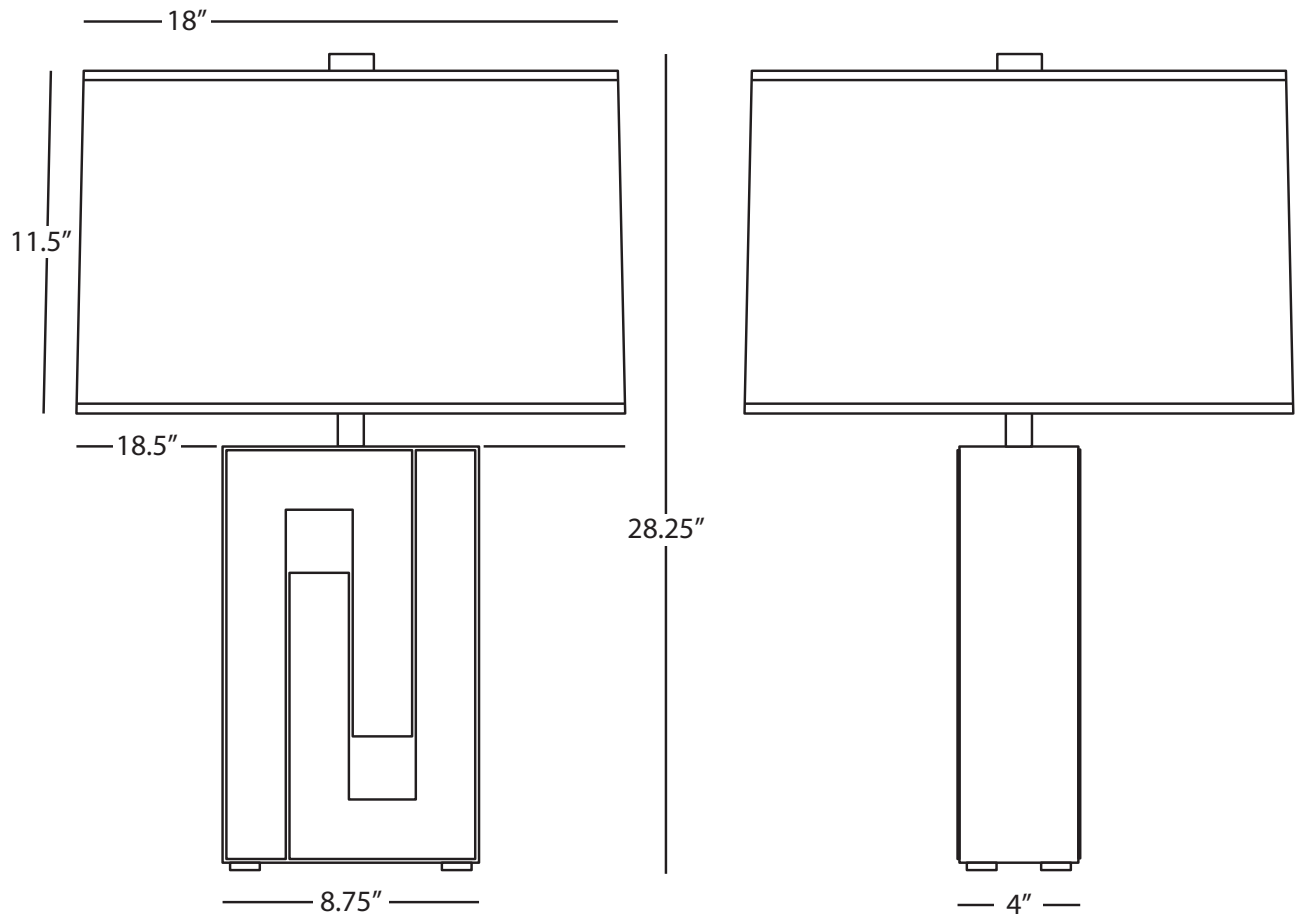

BLOX

BK579

Table Lamp

1 - 150W Max.
Bulb Type: A
Switch: Full Range Dimmer
Black Enamel Finish w/
Polished Nickel Accents
Ascot White Fabric Shade

FINISH OPTION:
WH579 White Enamel



C1334

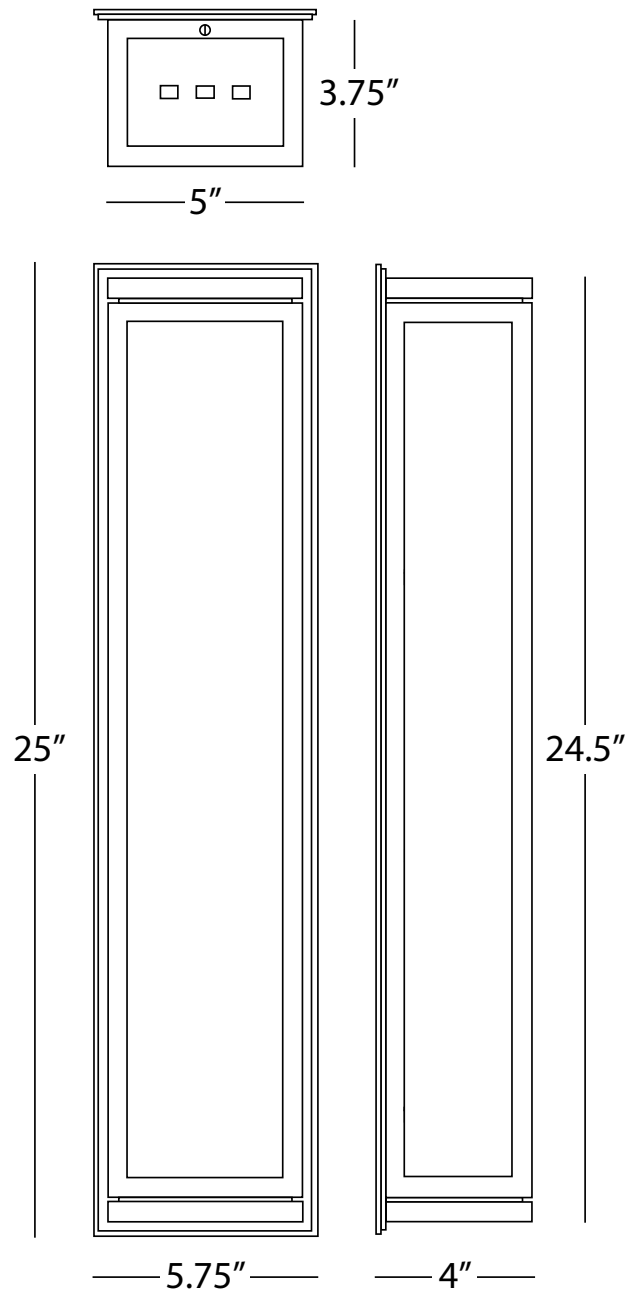

BRADLEY

C1334

Medium Wall Sconce

3 - 60W Max.
Bulb Type: B11 Torpedo
Direct Wire Only
Polished Chrome Finish
White Glass Shade
UL Rated for Damp Locations
ADA Compliant



Braxton

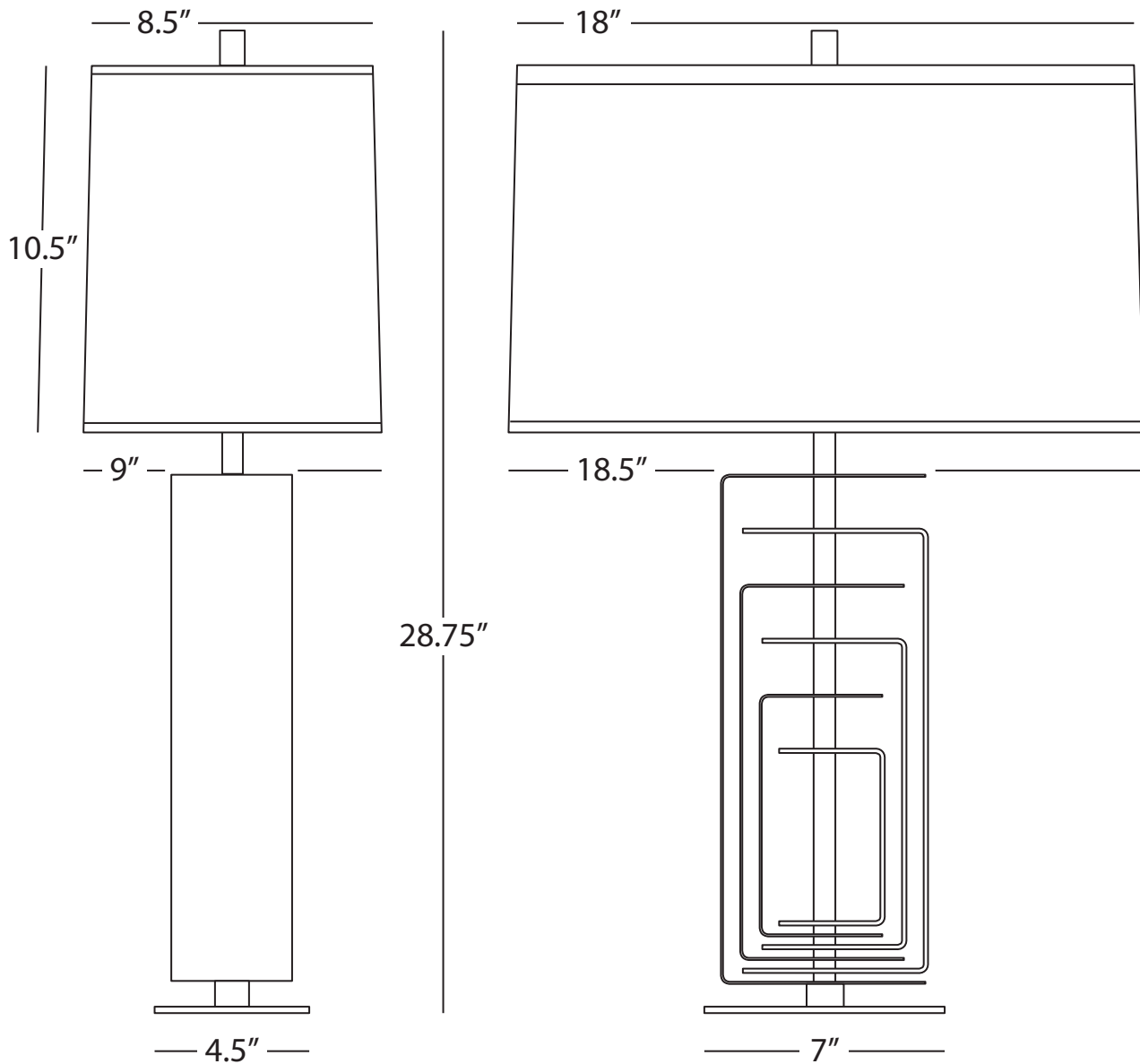

BRAXTON

279

Table Lamp

1 - 150W Max.
Bulb Type: A
Switch: Full Range Dimmer
Modern Brass Finish
Clear Acrylic Accents
Rectangular Fondine Fabric Shade



S3393



3391

Brighton

BRIGHTON

S3393

Ball Pendant

1 - 100W Max.
Bulb Type: A
Direct Wire
Polished Nickel Finish
Clear Halophane Glass Shade
Susp. Hardware: 3 Ft. Chain

FINISH OPTION:

3393 Modern Brass

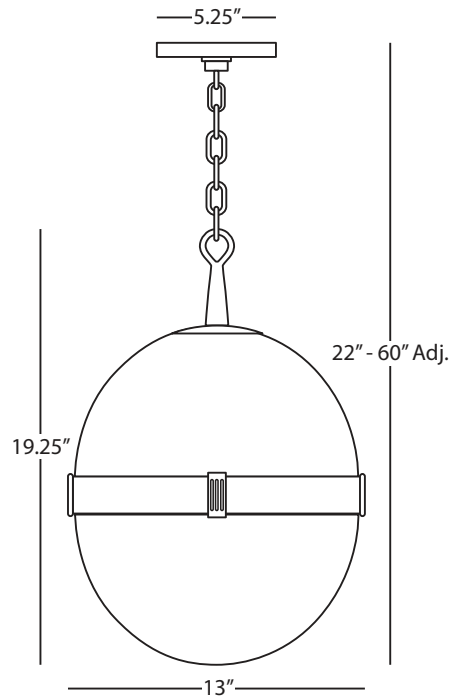

BRIGHTON

3391

Pendant

1 - 150W Max.
Bulb Type: A
Direct Wire
Modern Brass Finish
Matte Black Shade Hood
Clear Halophane Glass Diffuser
Susp. Hardware: 3 Ft. Chain

FINISH OPTION:

S3391 Polished Nickel

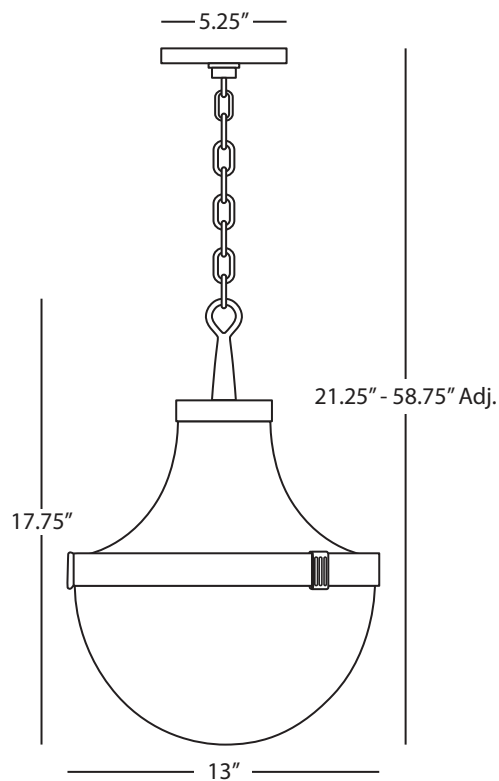



1849



1847



1848



1840

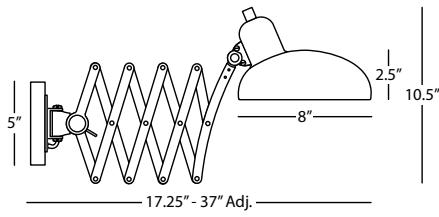

BRUNO

1849 Scissor Arm Wall Sconce

1 - 60W Max.
Bulb Type: A19, Silver Tip
Switch: On-Off
Cord Cover/Direct Wire
Lead Bronze Finish w/
Ebonized Nickel Accents
Metal Shade

Photographed with Silver Tip Bulb
SOLD SEPARATELY
(BULO1 See Page 225)

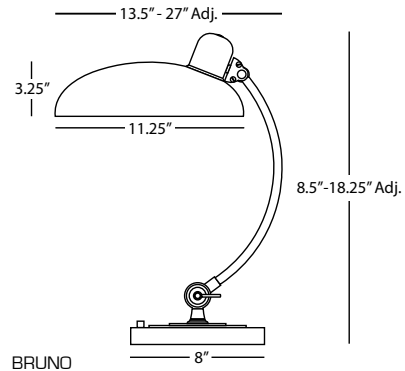

BRUNO

1840 Adjustable Task Table Lamp

1 - 60W Max.
Bulb Type: G25, Silver Tip
Switch: Hi-Lo Dimming
Lead Bronze Finish w/ Ebonized Nickel Accents
Lead Bronze Finished Metal Shade

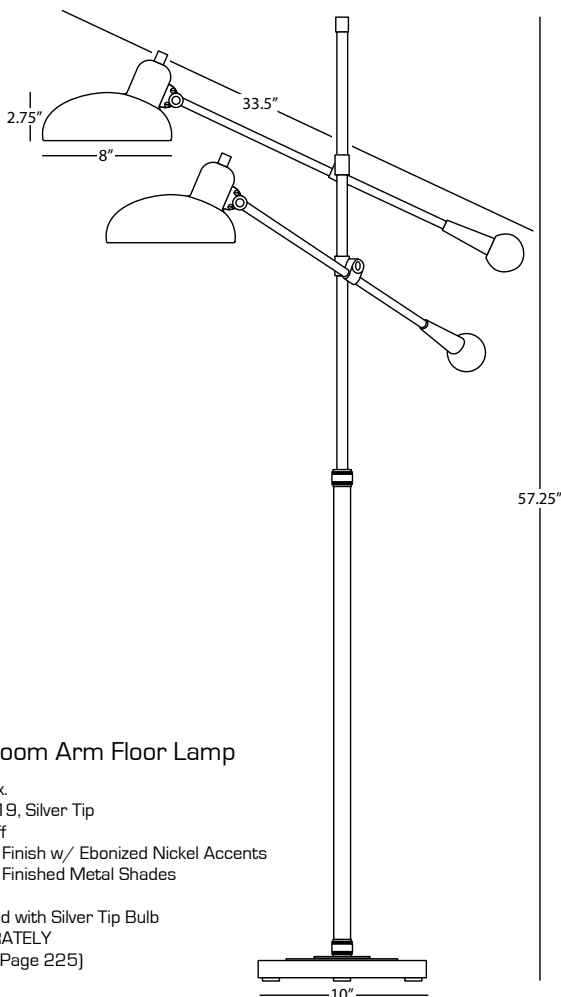

BRUNO

1848 Double Boom Arm Floor Lamp

2 - 60W Max.
Bulb Type: A19, Silver Tip
Switch: On-Off
Lead Bronze Finish w/ Ebonized Nickel Accents
Lead Bronze Finished Metal Shades

Photographed with Silver Tip Bulb
SOLD SEPARATELY
(BULO1 See Page 225)

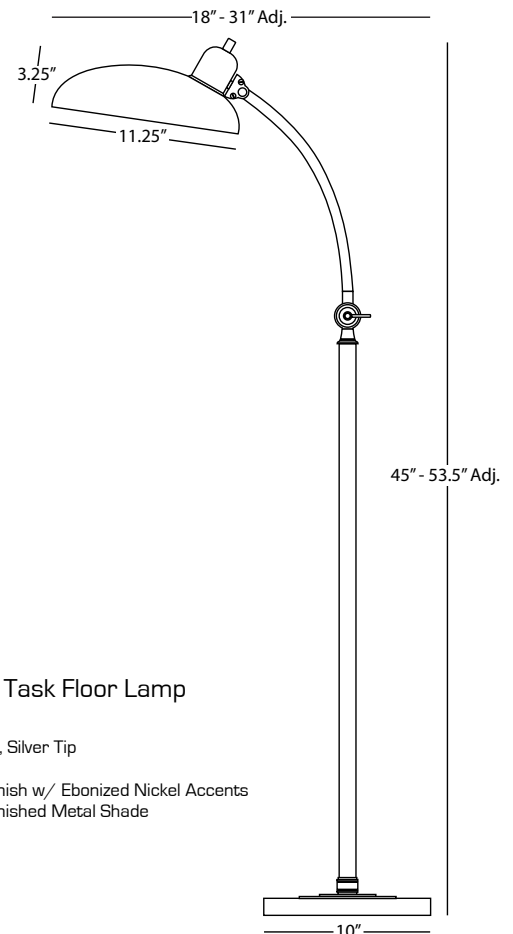

BRUNO

1847 Adjustable Task Floor Lamp

1 - 60W Max.
Bulb Type: G25, Silver Tip
Switch: On-Off
Lead Bronze Finish w/ Ebonized Nickel Accents
Lead Bronze Finished Metal Shade



1842X



1842W



1841



1841X

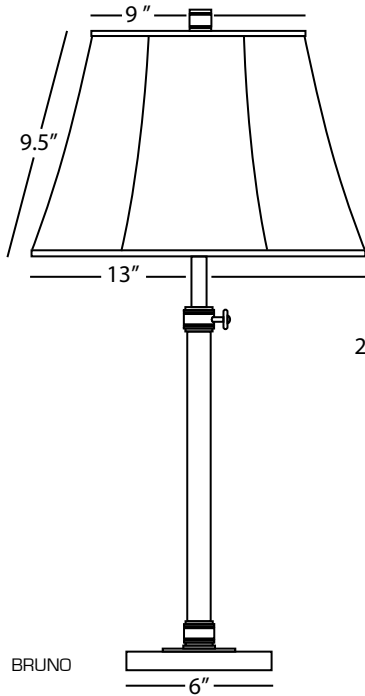

BRUNO

1841
Adjustable Column Table Lamp

1 - 150W Max.
Bulb Type: A
Switch: 3-Way
Lead Bronze Finish w/ Ebonized
Nickel Accents
Gray Microfiber Fabric Empire Shade

SHADE OPTIONS:
1841W Ivory Microfiber
1841X Fondine

26" - 32" Adj.

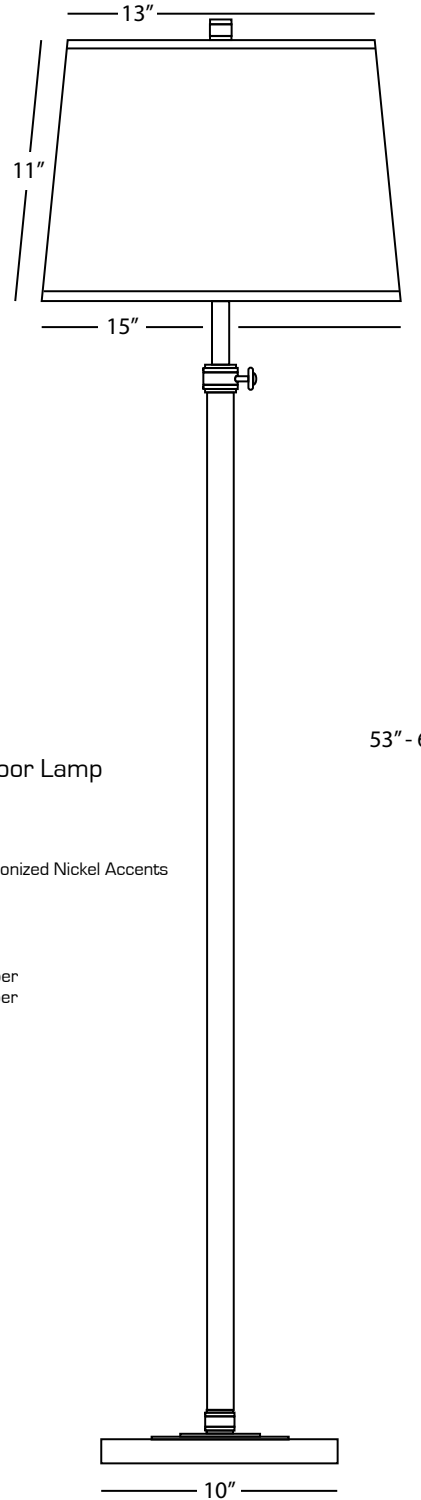

BRUNO

1842X
Adjustable Club Floor Lamp

1 - 150W Max.
Bulb Type: A
Switch: 3-Way
Lead Bronze Finish w/ Ebonized Nickel Accents
Fondine Fabric Shade

SHADE OPTIONS:
1842 Gray Microfiber
1842W Ivory Microfiber

53" - 61" Adj.



C1319



1319



Z1318



C1318



B1318

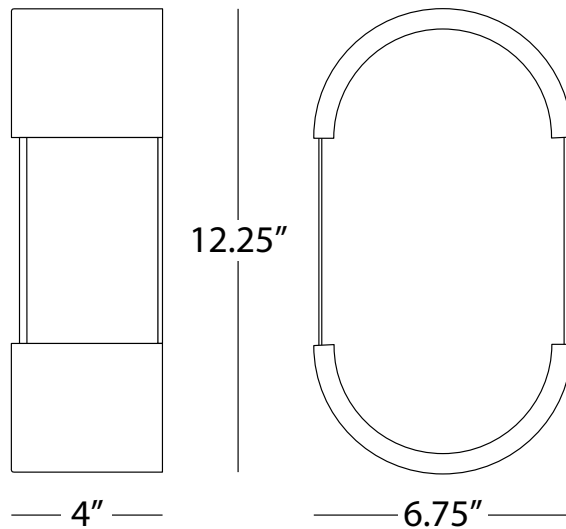

BRYCE

B1318

Wall Sconce

2 - 60W Max.
Bulb Type: B, Medium Base
Direct Wire Only
Brushed Nickel Finish
White Glass Shade
UL Rated for Damp Locations
ADA Compliant

FINISH OPTIONS:

1318 Antique Brass
C1318 Polished Chrome
Z1318 Deep Patina Bronze

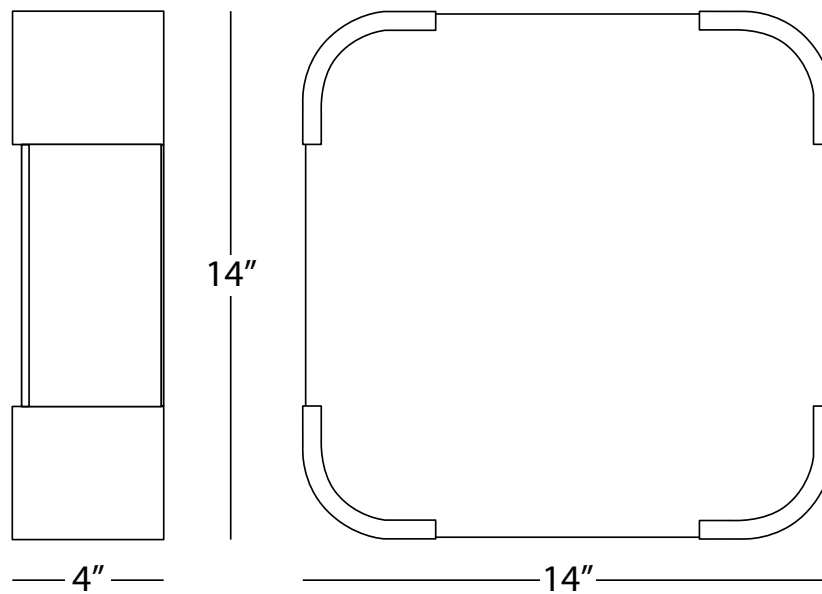

BRYCE

1319

Flush Mount

3 - 60W Max.
Bulb Type: B, Medium Base
Direct Wire
Antique Brass Finish
White Glass Shade
UL Rated for Damp Locations

FINISH OPTIONS:

C1319 Polished Chrome
Z1319 Deep Patina Bronze



292B



S291

CAMPBELL

S291
Task Table Lamp

1 - 100W Max.
Bulb Type: A
Switch: Full Range Dimmer
Polished Nickel Finish
Oyster Linen Shade

FINISH/SHADE OPTIONS:

S291B Polished Nickel/Anna Black Fabric w/ Silver Lining

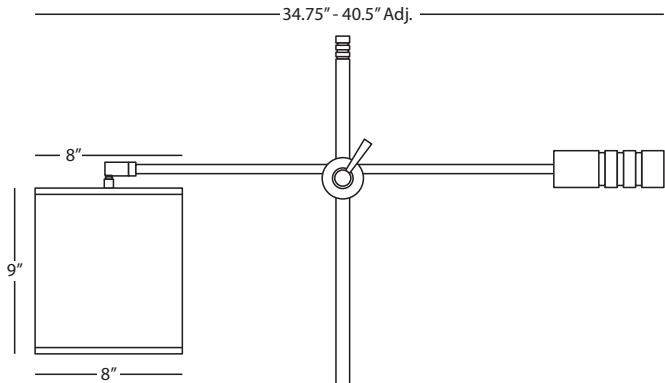
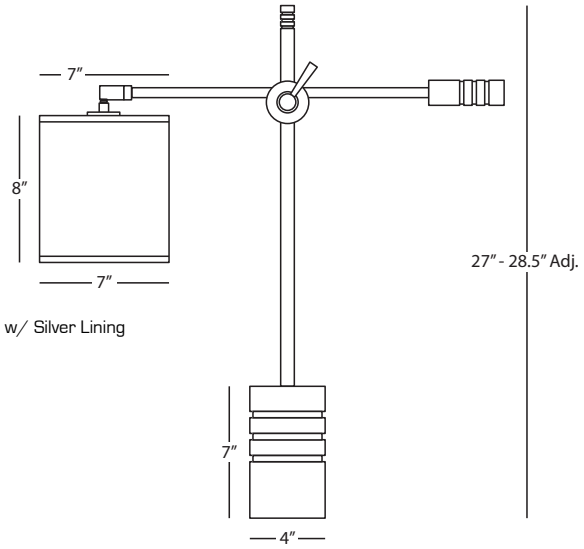
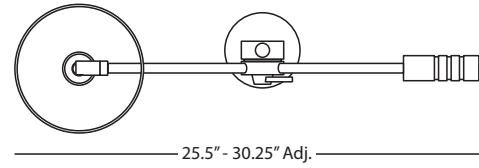

CAMPBELL

292B
Task Floor Lamp

1 - 100W Max.
Bulb Type: A
Switch: Full Range Dimmer
Modern Brass Finish
Anna Black Fabric Shade w/ Gold Lining

FINISH/SHADE OPTIONS:

292 Modern Brass/Oyster Linen
S292 Polished Nickel/Oyster Linen
S292B Polished Nickel/Anna Black Fabric w/ Silver Lining

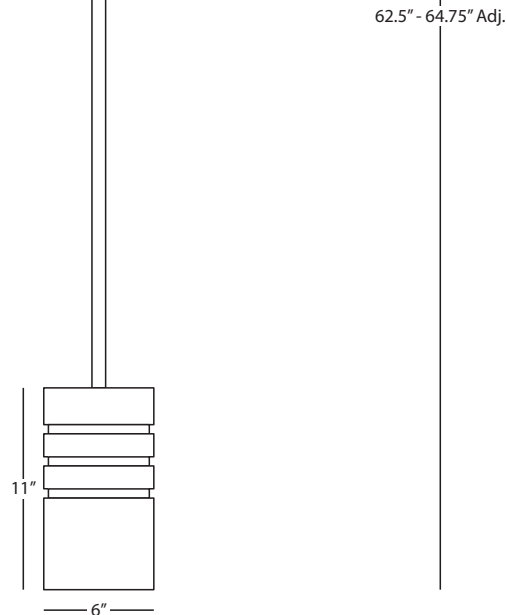



S388

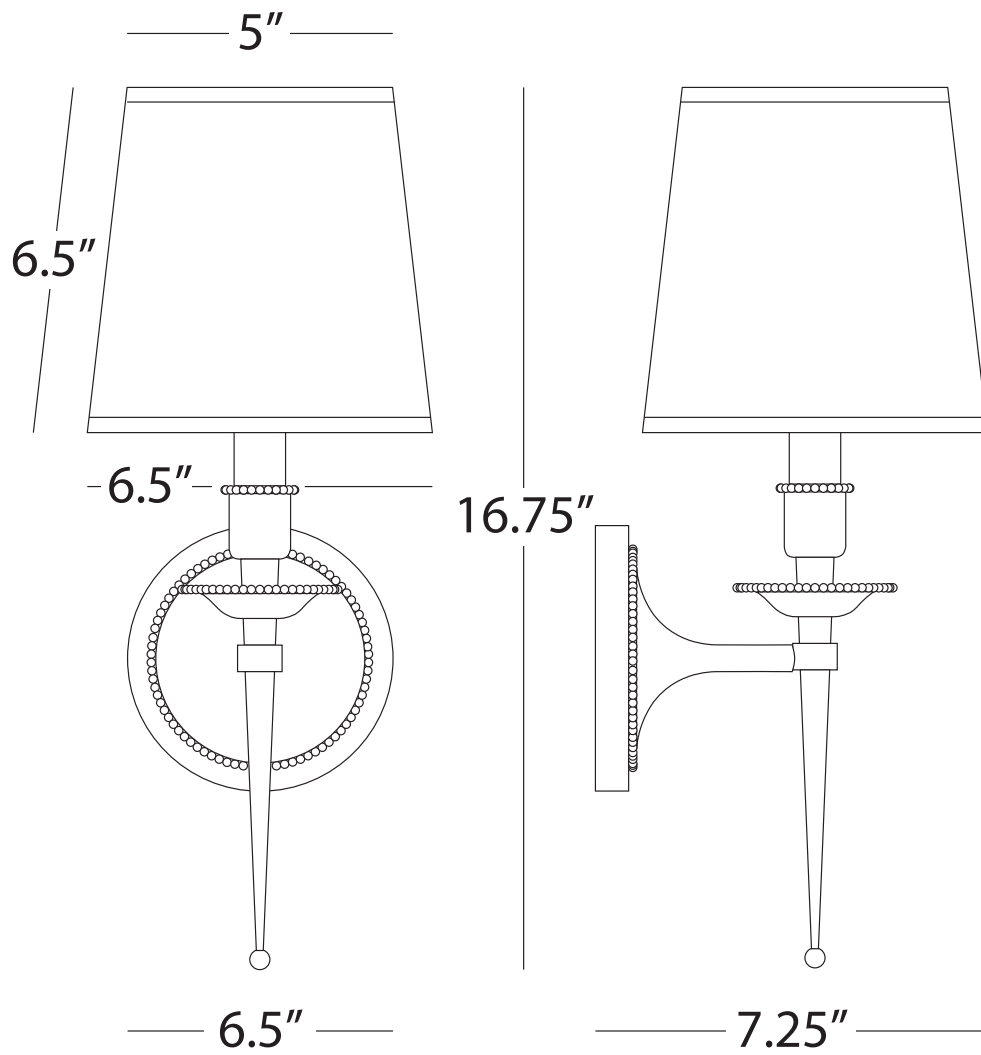

CEDRIC

S388

Wall Sconce

1 - 60W Max.
Bulb Type: B, Candelabra Base
Switch: On-Off Line Switch
Polished Nickel Finish
Ascot White Fabric Shade



1215



S1215

Celeste

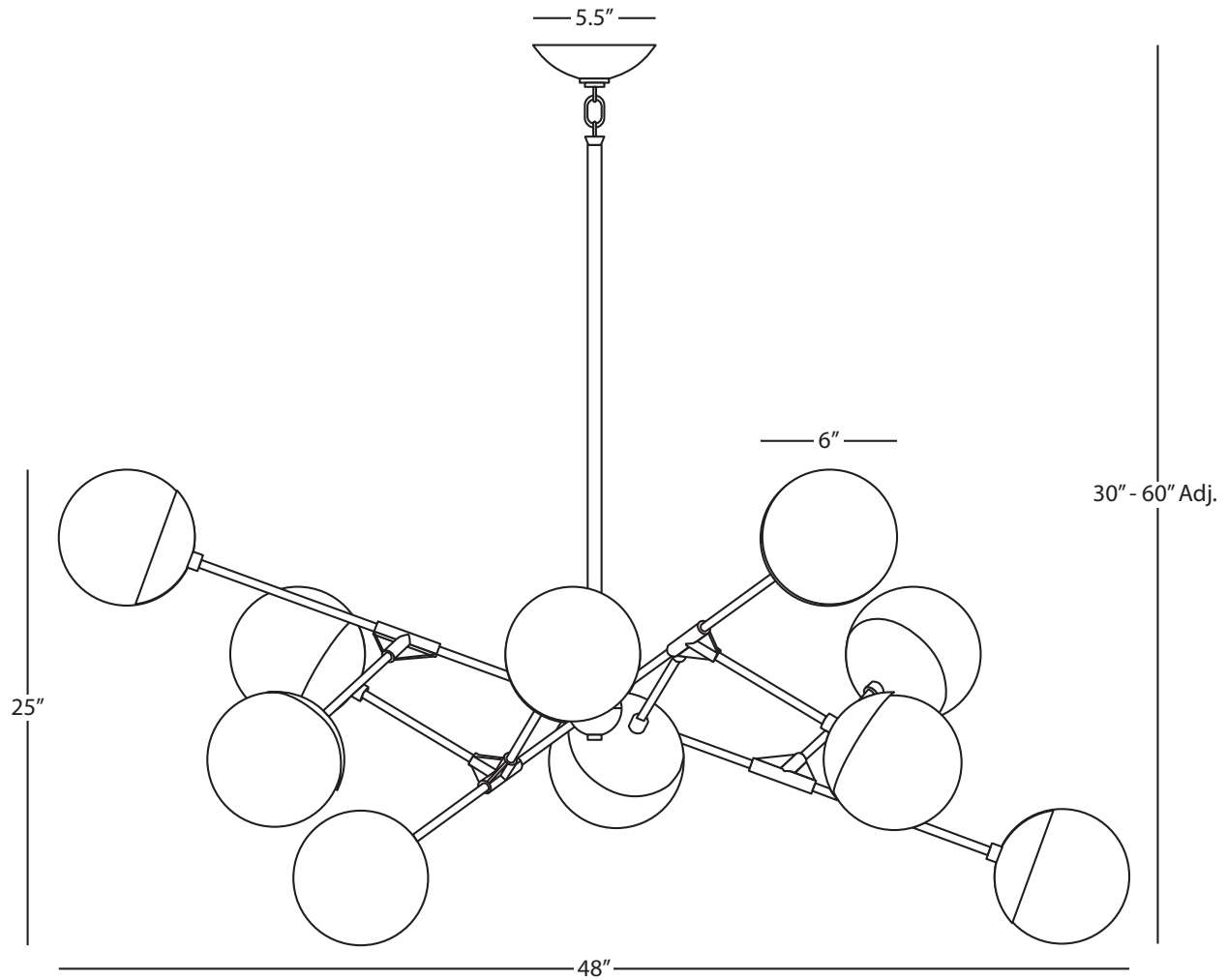

CELESTE

1215

Chandelier

12 - 40W Max.
Bulb Type: A15
Direct Wire
Modern Brass Finish
Clear Glass Globe Shades
Susp. Hardware: 1 pc. 5/8" x 6" & 3 pcs.
5/8" x 12" Extensions

FINISH OPTION:

S1215 Polished Nickel

Celeste



S1217



1216

Celeste



[Click photo above to watch Celeste video](#)

Beauty and kinetic energy are at the heart of Celeste's design. Reminiscent of a constellation of stars, this collection is perfect for creating a striking, modern focal point in your space.



S1217



1217



1216



S1216

Celeste

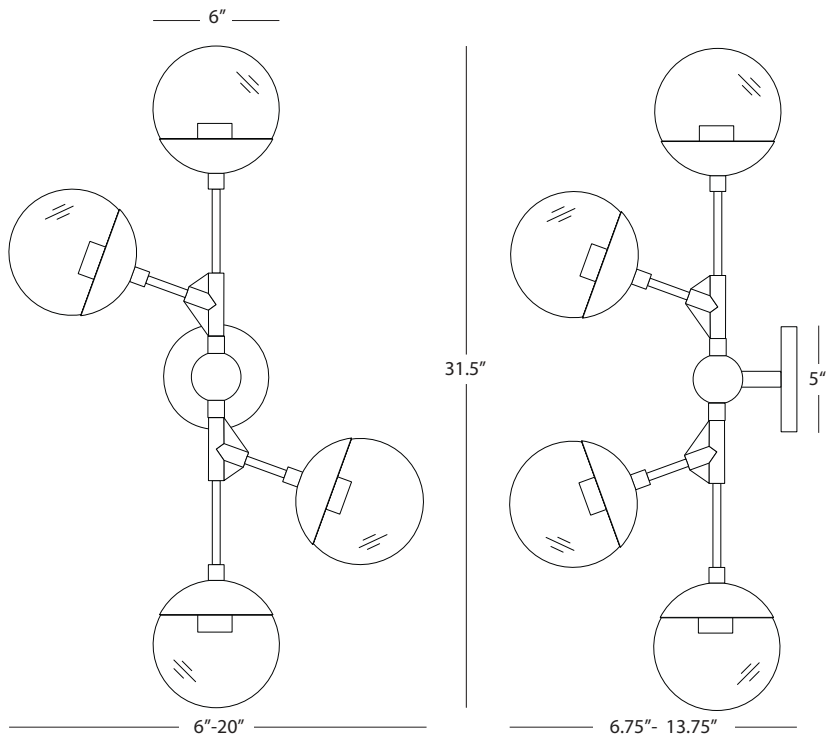

CELESTE
1216
Wall Sconce
 4 - 40W Max.
 Bulb Type: A15 (Short Neck)
 Direct Wire Only
 Modern Brass Finish
 Clear Glass Shade
 UL Rated Damp Locations
 FINISH OPTIONS:
S1216 Polished Nickel

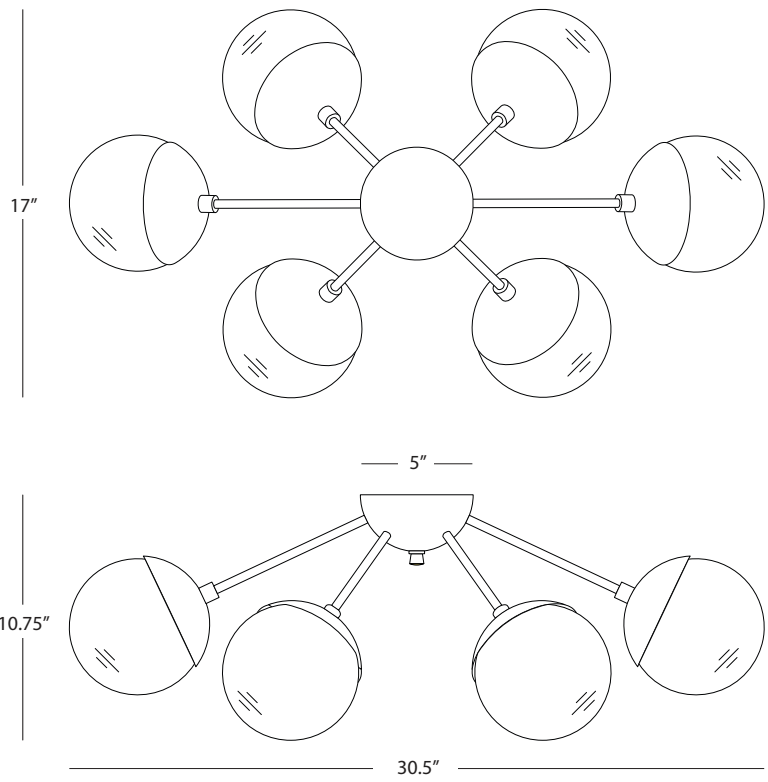

CELESTE
S1217
Flush Mount
 6 - 40W Max.
 Bulb Type: A15 (Short Neck)
 Direct Wire Only
 Polished Nickel Finish
 Clear Glass Shade
 UL Rated Damp Locations
 FINISH OPTIONS:
1217 Modern Brass

Celine



Celine

[Click photo above to watch Celine Table Lamp Video](#)

The name Celine means “heavenly” and this beautiful collection speaks the language of the moon—serene and enchanting. With a clear crystal ball and contrasting deep patina bronze accents, Celine makes a space feel polished and elegant.

Celine



Celine

[Click photo above to watch Celine Accent Lamp Video](#)

The name Celine means “heavenly” and this beautiful collection speaks the language of the moon—serene and enchanting. With a clear crystal ball and contrasting deep patina bronze accents, Celine makes a space feel polished and elegant.



1013



1014

Celine

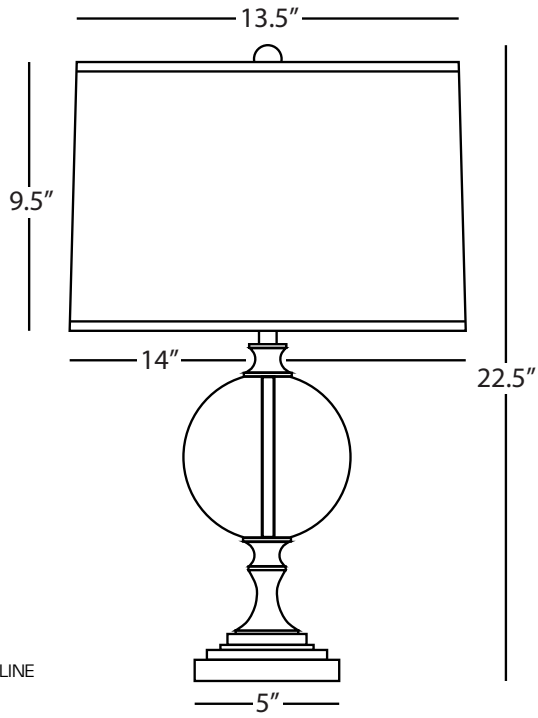

CELINE

1013

Accent Lamp

1 - 150W Max.
 Bulb Type: A
 Switch: Full Range Dimmer
 Deep Patina Bronze Finish w/
 Clear Crystal Ball
 Painted Bronze Parchment Shade w/
 Bright Silver Lining

SHADE OPTION:
1013X Pearl Dupioni

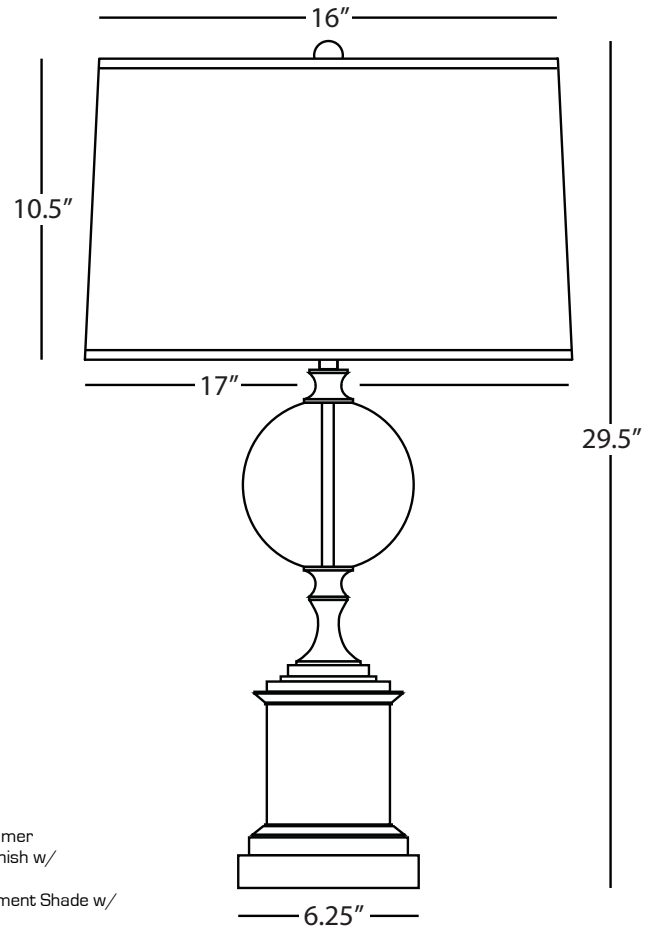

CELINE

1014

Table Lamp

1 - 150W Max.
 Bulb Type: A
 Switch: Full Range Dimmer
 Deep Patina Bronze Finish w/
 Clear Crystal Ball
 Painted Bronze Parchment Shade w/
 Bright Silver Lining

SHADE OPTION:
1014X Pearl Dupioni



1022X



1022

Celine

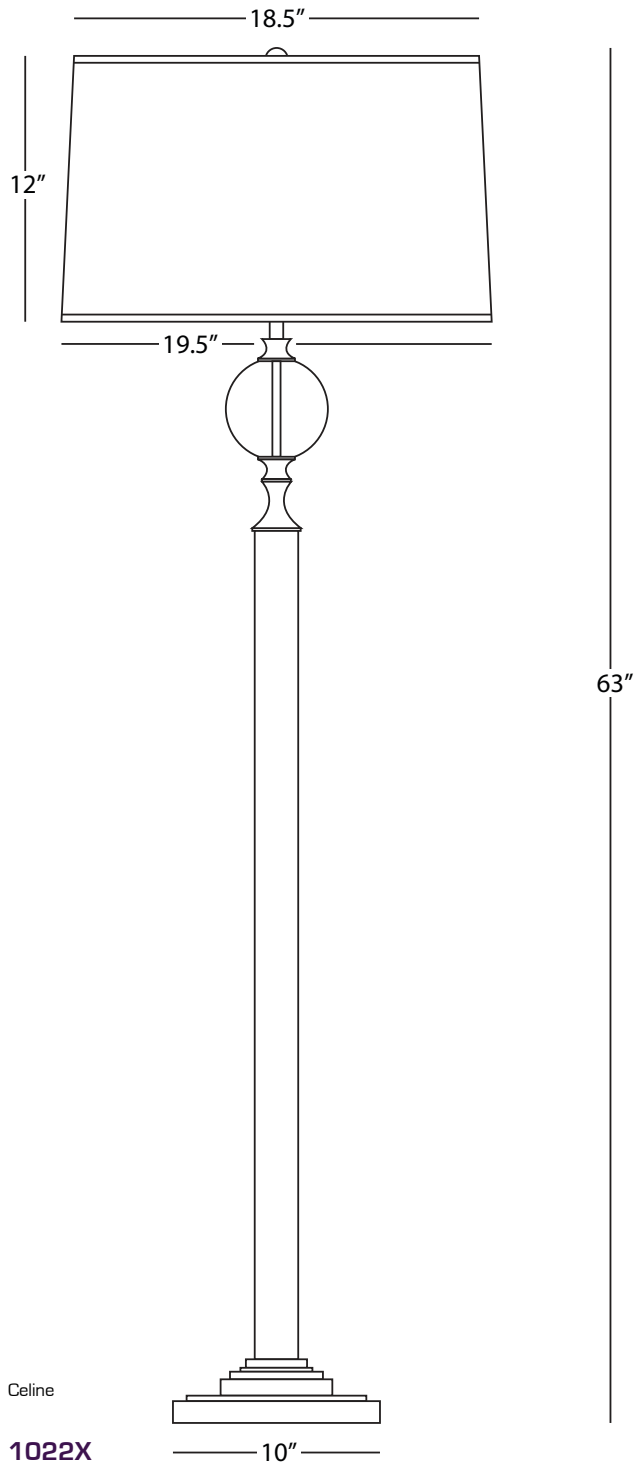

1022X
Floor Lamp

1 - 150W Max.
Bulb Type: A
Switch: Full Range Dimmer
Deep Patina Bronze Finish
Crystal Accents
Pearl Dupioni Silk Fabric Shade

FINISH OPTIONS:
1022 Deep Patina Bronze
Crystal Accents
Bronze Opaque Parchment
with Matte Silver Lining

Charlee



Charlee

[Click photo above to watch Charlee Table Lamp Video](#)

Ideal for an office desk or reading area, the Charlee table lamp features stylish curves and a double armed design. Charlee's tiered fabric shades adjust so you can direct the light to suit your needs.



B587



C587B



G587B



Z587

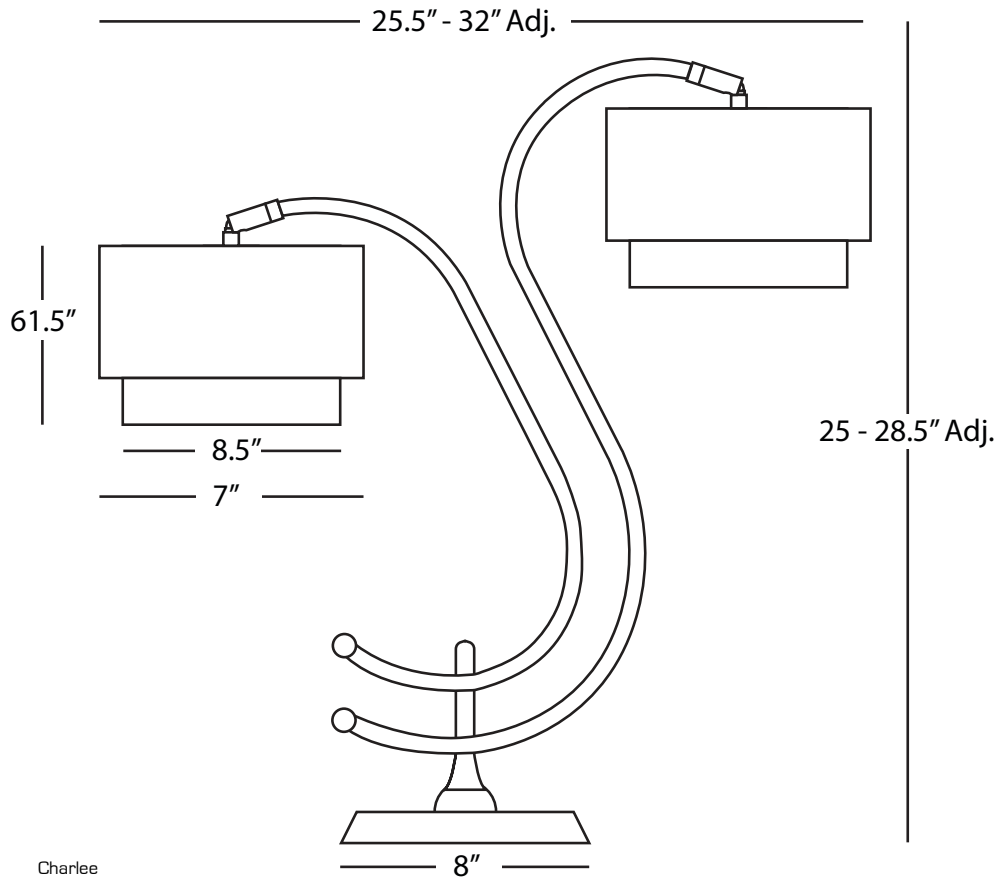

Charlee

B587

Double Arm Table Lamp

2 - 100W Max.

Bulb Type: A

Switch: Full Range Dimmer Line Switch

Matte Black Powder Coat Finish

Ascot White Fabric Shades

FINISH OPTIONS:

- B587B Matte Black/Raven Black
- C587 Chrome/Ascot White
- C587B Chrome/Raven Black
- G587 Gunmetal/Ascot White
- G587B Gunmetal/Raven Black
- Z587 Dark Bronze/Ascot White



1988



1985



D1985



S1987



D1986

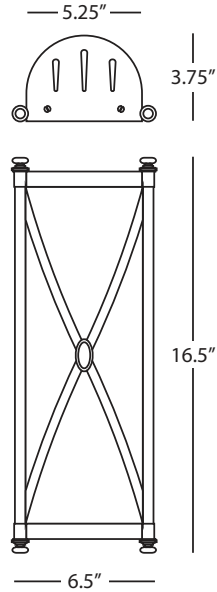

CHASE

D1986
Small Wall Sconce

2 - 40W Max.
Bulb Type: B, Medium Base
Direct Wire Only
Dark Antique Nickel Finish
Frosted White Cased Glass Shade
UL Rated for Damp Locations
ADA Compliant
Can Be Mounted Horizontally or Vertically

FINISH OPTIONS:

- 1986** Antique Brass
- S1986** Polished Nickel
- Z1986** Deep Patina Bronze

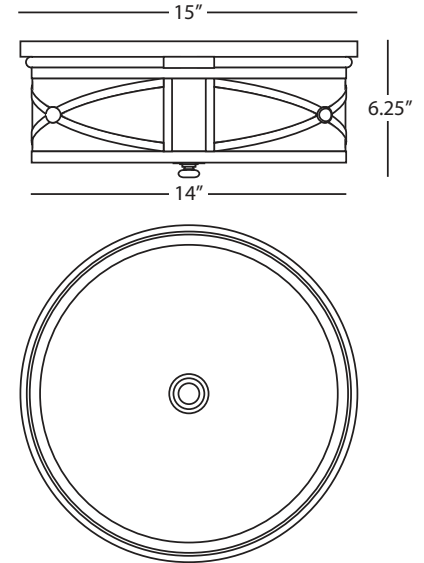

CHASE

1985
Flush Mount

3 - 60W Max.
Bulb Type: A
Direct Wire Only
Antique Brass Finish
Frosted White Glass Shade

FINISH OPTIONS:

- D1985** Dark Antique Nickel
- S1985** Polished Nickel
- Z1985** Deep Patina Bronze

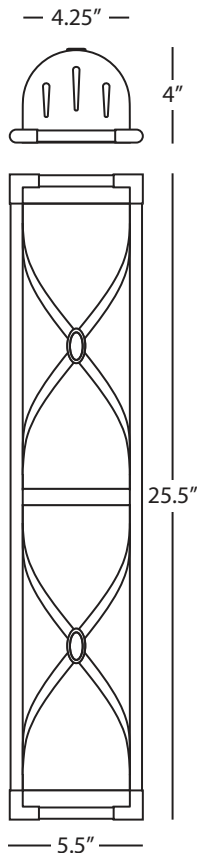

CHASE

S1987
Medium Wall Sconce

4 - 60W Max.
Bulb Type: B, Medium Base
Direct Wire Only
Polished Nickel Finish
Frosted White Cased Glass Shade
UL Rated for Damp Locations
ADA Compliant
Can Be Mounted Horizontally or Vertically

FINISH OPTIONS:

- 1987** Antique Brass
- D1987** Dark Antique Nickel
- Z1987** Deep Patina Bronze

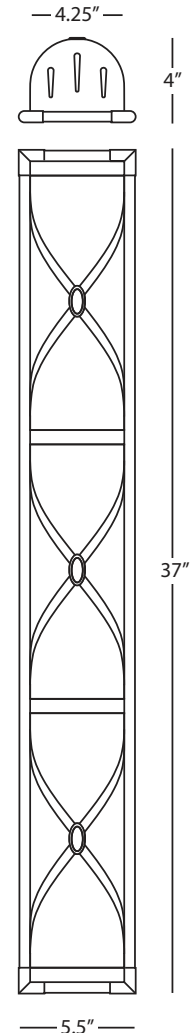

CHASE

1988
Large Wall Sconce

6 - 60W Max.
Bulb Type: B, Medium Base
Direct Wire Only
Antique Brass Finish
Frosted White Cased Glass Shade
UL Rated for Damp Locations
ADA Compliant
Can Be Mounted Horizontally or Vertically

FINISH OPTIONS:

- S1988** Polished Nickel

| Chloe



Chloe

[Click photo above to watch Chloe Table Lamp Video](#)

Sculptural spirals with just a touch of whimsy are at the heart of Chloe's design. Give your space artistic appeal with this table lamp's sense of movement and style.



D586



586

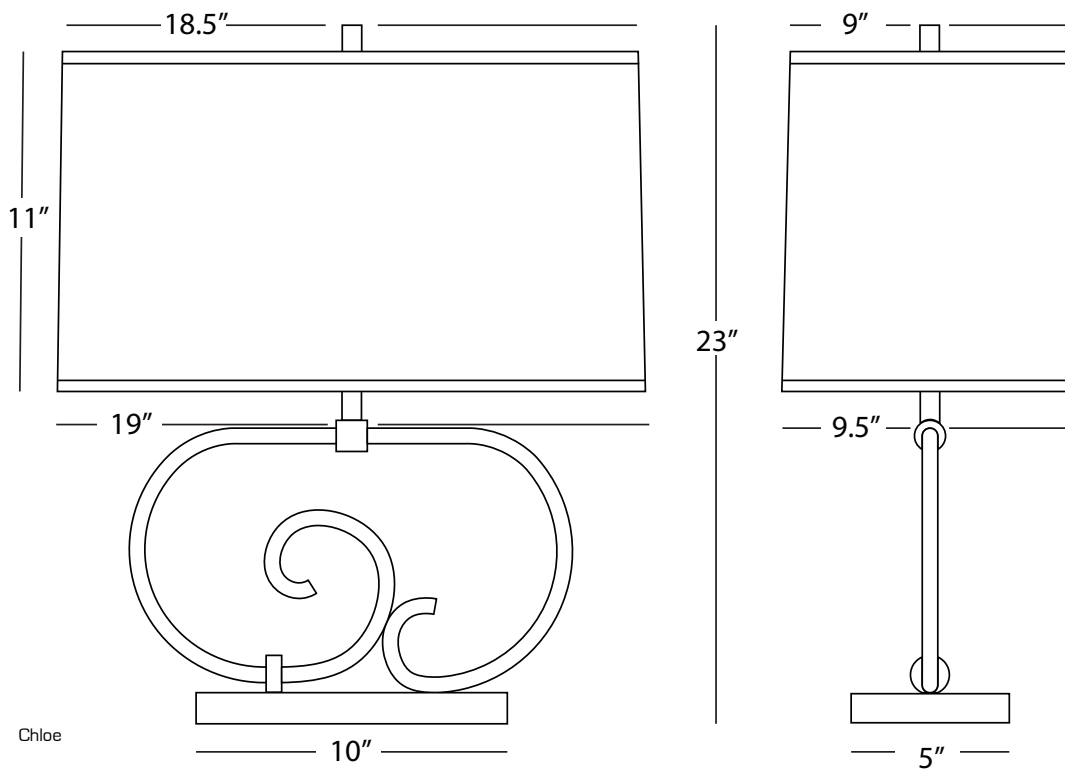

Chloe

D586
Table Lamp

1 - 150W Max.
Bulb Type: A
Switch: Full Range Dimmer
Dark Antique Nickel Finish
Matte Black Base
Oval Pearl Dupoini Fabric Shade

FINISH OPTIONS:
586 Warm Brass

Cinch



Cinch

[Click photo above to watch Cinch Table Lamp video](#)

Cinch's design is simple but dramatic. An exaggerated hourglass shape and matte black finish make this collection a stylish choice for modern spaces.

Cinch



1250



1251



1252

Cinch

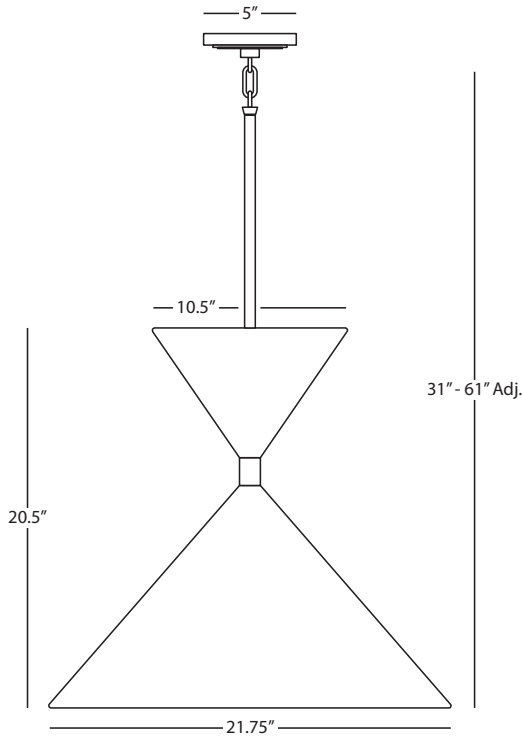

CINCH

1251

Pendant

1 - 60W Max.
 Bulb Type: A
 Direct Wire
 Matte Black Painted Finish
 Matching Metal Shade w/ White Interior
 Susp. Hardware: 1 pc. 5/8" x 6" & 3 pcs.
 5/8" x 12" Extensions

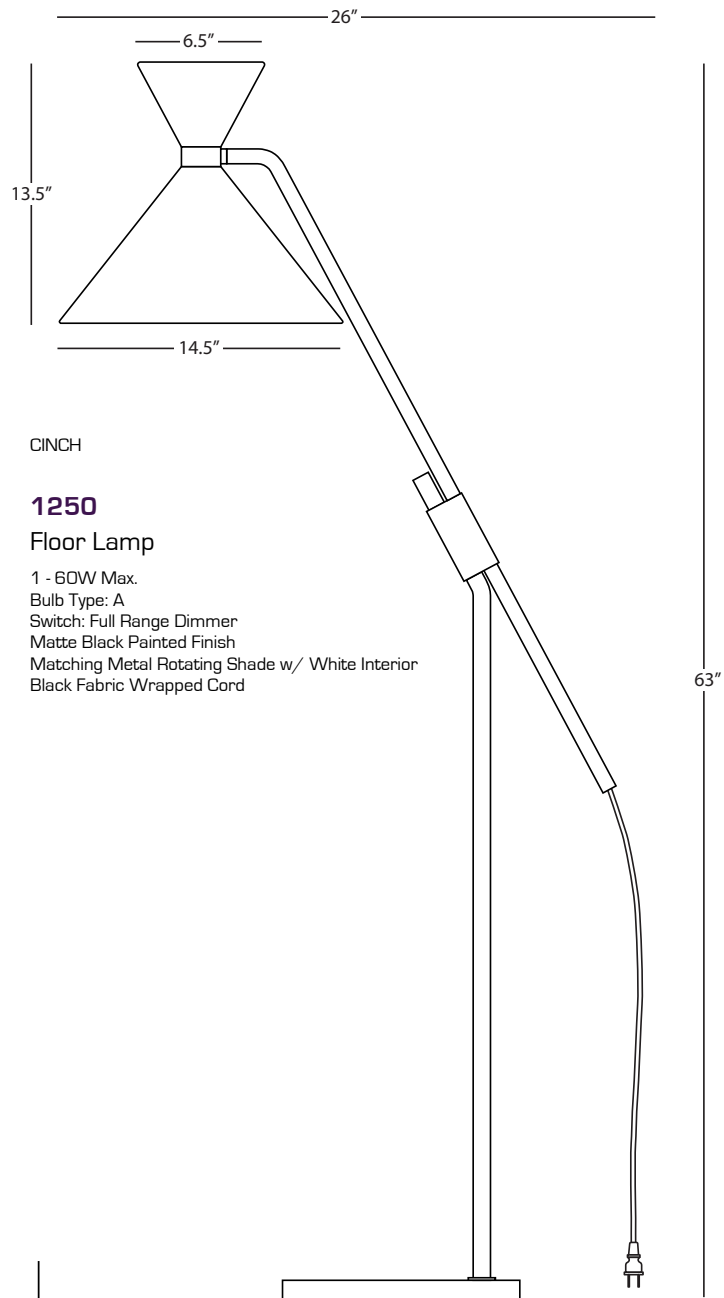

CINCH

1250

Floor Lamp

1 - 60W Max.
 Bulb Type: A
 Switch: Full Range Dimmer
 Matte Black Painted Finish
 Matching Metal Rotating Shade w/ White Interior
 Black Fabric Wrapped Cord

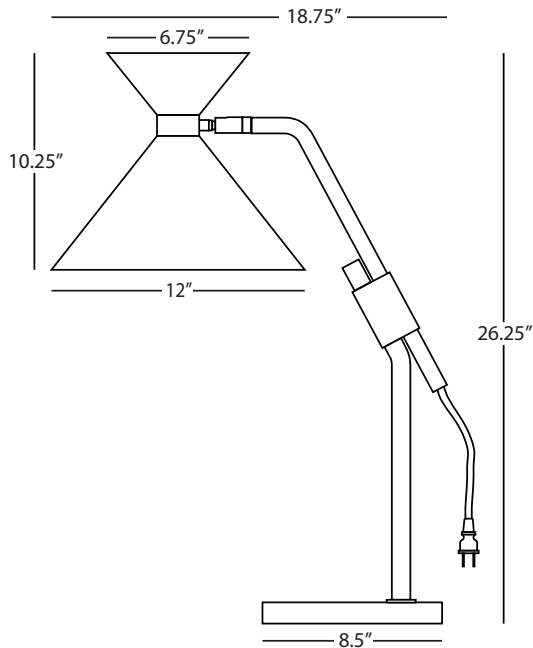

CINCH

1252

Table Lamp

1 - 60W Max.
 Bulb Type: A
 Switch: Full Range Dimmer
 Matte Black Painted Finish
 Matching Metal Shade w/ White Interior
 Black Fabric Wrapped Cord

Cinch



Cinch



[Click photo above to watch Cinch video](#)

Cinch's design is simple but dramatic. An exaggerated hourglass shape and matte black finish make this collection a stylish choice for modern spaces.



1254



1253

Cinch

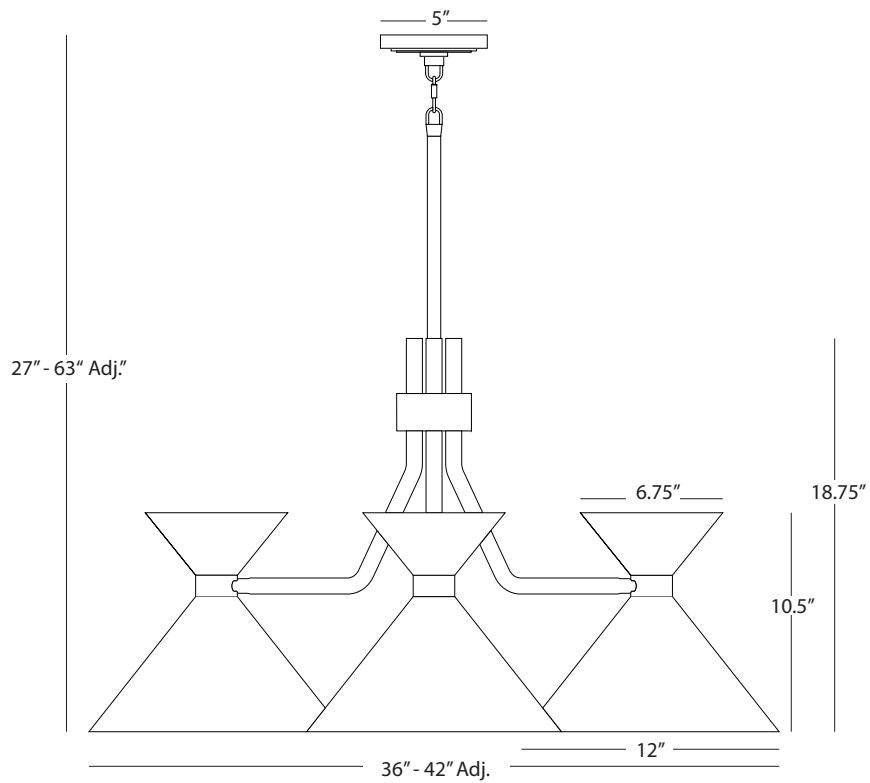

CINCH

1254 Pendant

3 - 60W Max.
Bulb Type: A
Direct Wire Only
Matte Black Painted Finish
Metal Shade with White Interior
Susp. Hardware: 3 pcs. 5/8" x 12" & 1 pc.
5/8" x 6" Extension Rods

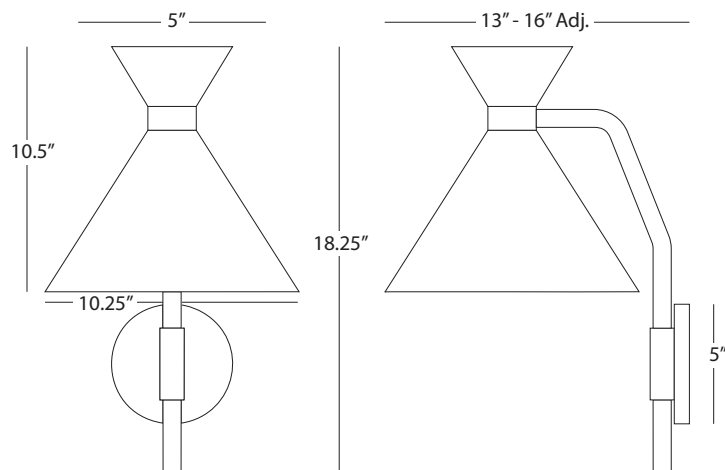

CINCH

1253 Swing Arm Sconce

1 - 60W Max.
Bulb Type: A
Switch: Full Range Dimmer
24" Cord Cover/Direct Wire
Matte Black Painted Finish
Metal Shade with White Interior



S3337



S3336

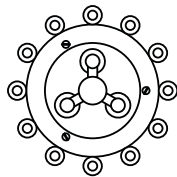
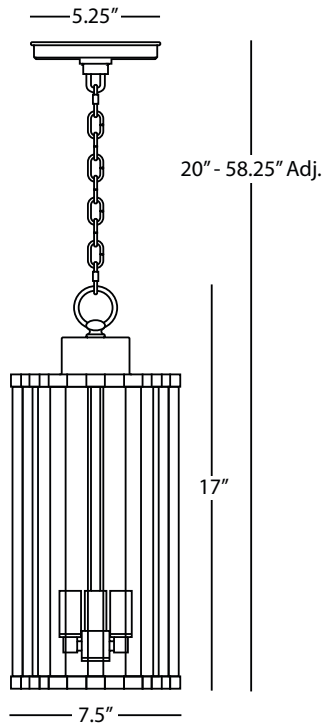

COLE

S3336

Small Narrow Pendant

3 - 60W Max.
 Bulb Type: B, Candelabra
 Direct Wire Only
 Clear Glass Rods w/ Clear Inner Glass Shade
 Polished Nickel Finished Accents
 Susp. Hardware: 3 Ft. Chain

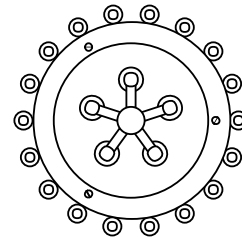
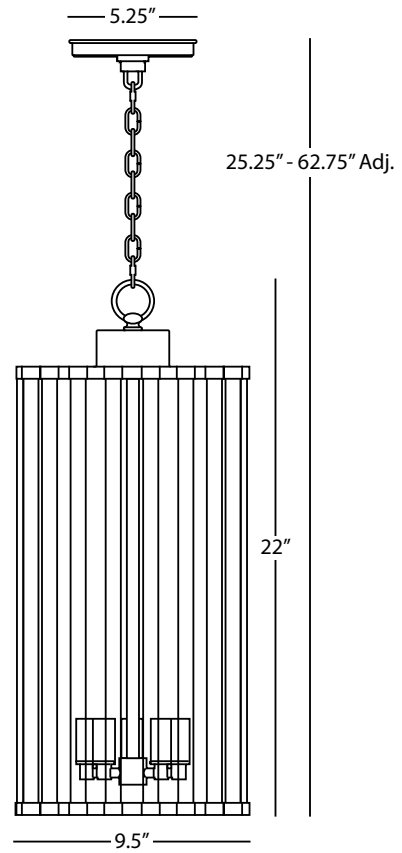

COLE

S3337

Large Narrow Pendant

5 - 60W Max.
 Bulb Type: B, Candelabra
 Direct Wire Only
 Clear Glass Rods w/ Clear Inner Glass Shade
 Polished Nickel Finished Accents
 Susp. Hardware: 3 Ft. Chain



1245

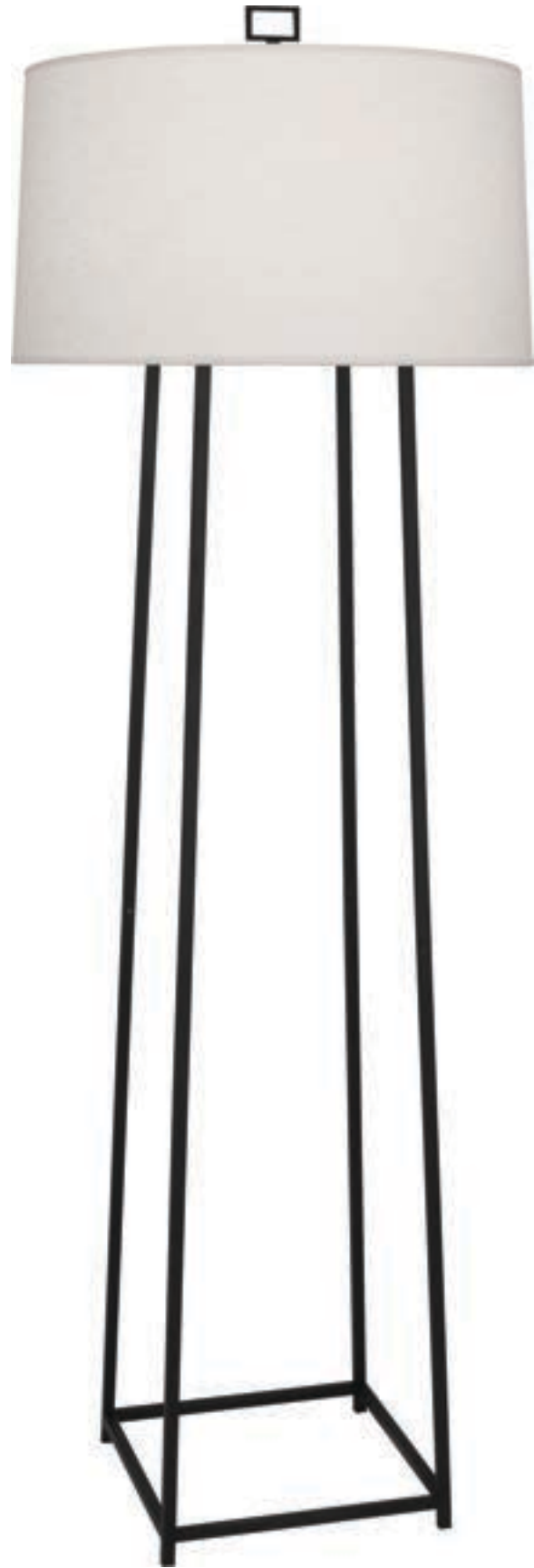

1246

Cooper

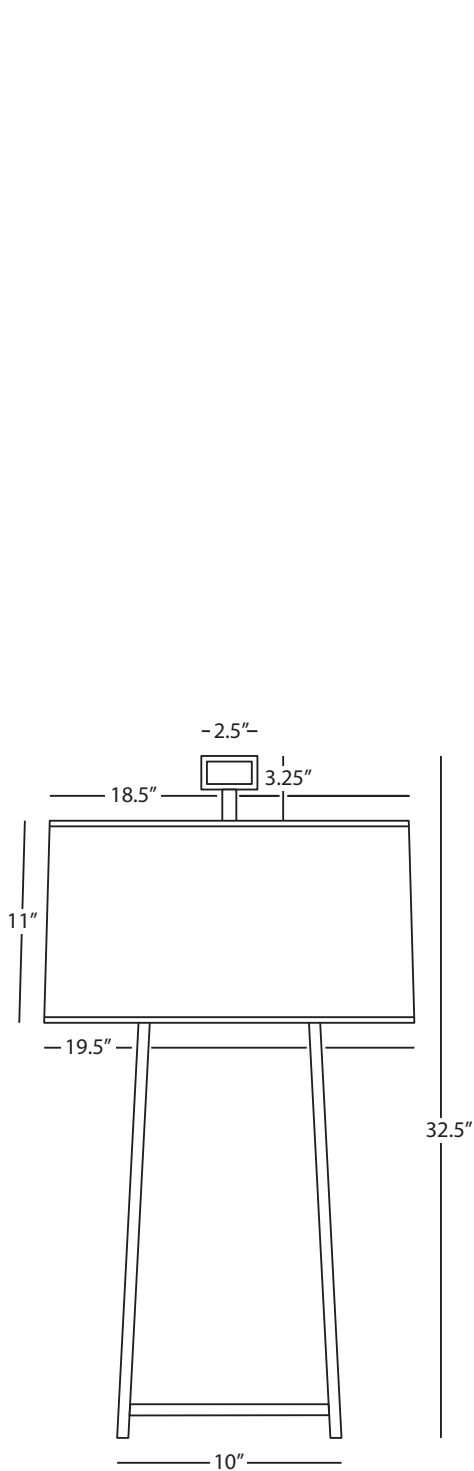

COOPER

1245

Table Lamp

1 - 150W Max.
Bulb Type: A
Switch: Full Range Dimmer
Wrought Iron Finish
Oyster Linen Shade

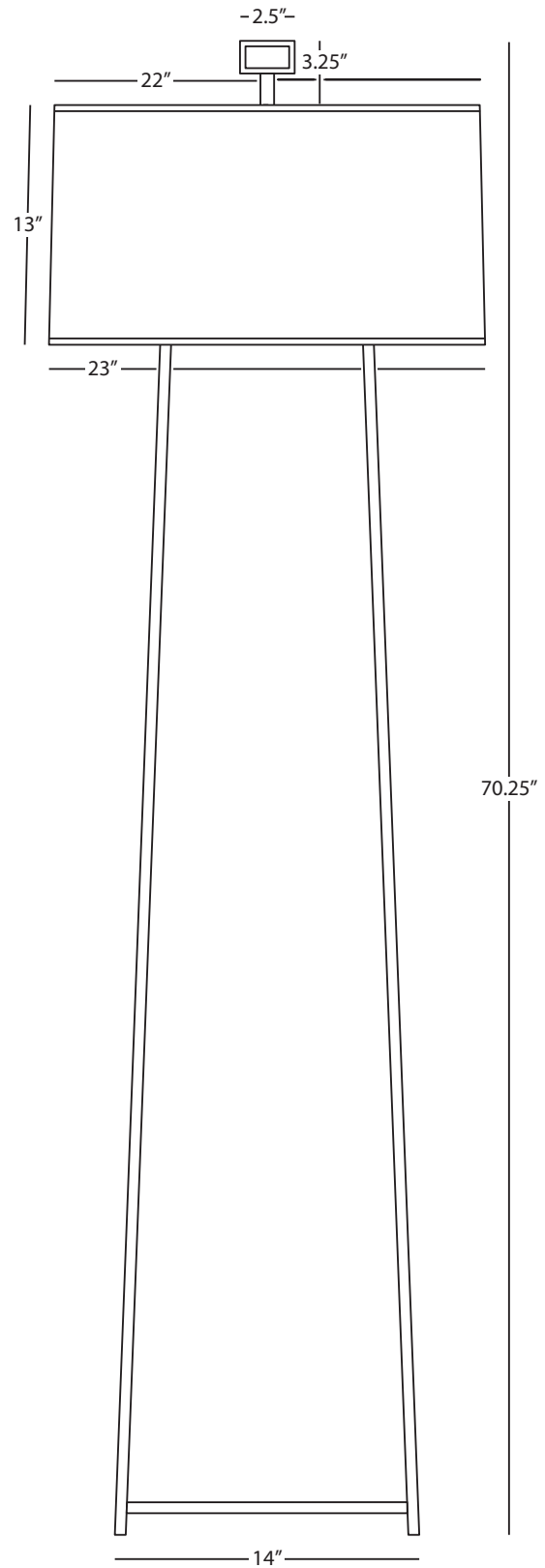

COOPER

1246

Floor Lamp

1 - 150W Max.
Bulb Type: A
Switch: Full Range Dimmer
Wrought Iron Finish
Oyster Linen Shade



1016



1018



S1015



S1017

Cosmos

COSMOS

1018

Chandelier

7 - 60W Max.
 Bulb Type: B, Candelabra Base
 1 - 5W Max.
 Bulb Type: GU10 LED MR16
 Direct Wire
 Deep Patina Bronze Finish w/
 Warm Brass Accents
 Oyster Linen Fabric Shades
 Frosted Glass Diffuser
 Susp. Hardware: 3 pcs. 1/2" x 6" &
 9 pcs. 1/2" x 12" Extensions

FINISH OPTION:

S1018 Antique Silver Accents

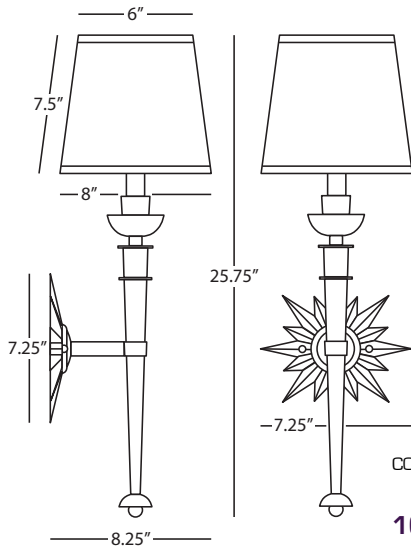
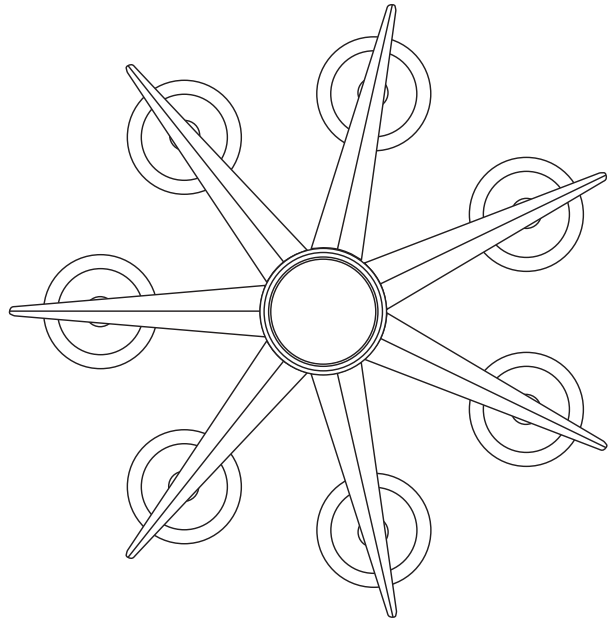

COSMOS

1016

Wall Sconce

1 - 60W Max.
 Bulb Type: B, Candelabra
 Direct Wire Only
 Deep Patina Bronze Finish w/
 Warm Brass Accents
 Oyster Linen Fabric Shade

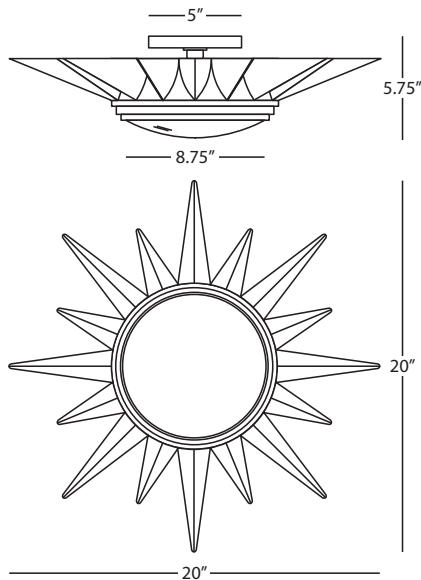
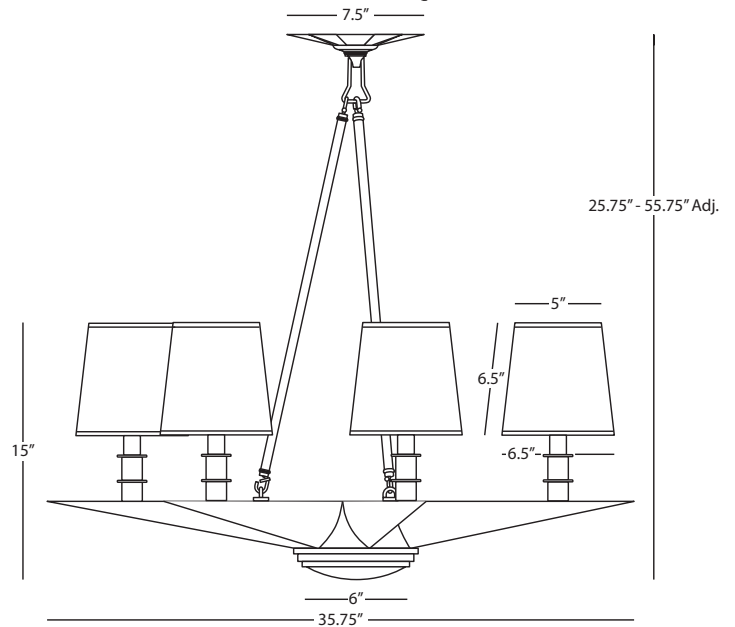

COSMOS

S1017

Flush Mount

2 - 60W Max.
 Bulb Type: B, Candelabra Base
 Direct Wire
 Deep Patina Bronze Finish w/
 Antique Silver Accents
 Frosted Glass Diffuser

FINISH OPTION:

1017 Warm Brass Accents

COSMOS

S1015

Table Lamp

1 - 150W Max.
 Bulb Type: A
 Switch: Full Range Dimmer
 Deep Patina Bronze Finish w/
 Antique Silver Accents
 Oyster Linen Fabric Shade

FINISH OPTION:

1015 Warm Brass Accents

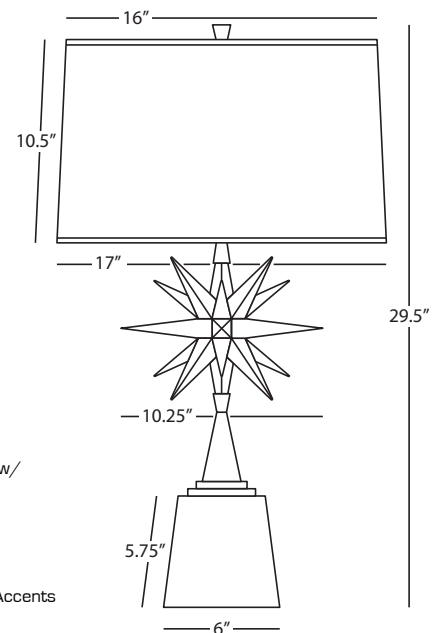

Cosmos



Cosmos



Click photo above to watch Cosmos video

Our Cosmos collection will compliment any space, adding extra appeal with contrasting finishes and a bold, dynamic design that is unforgettable.



1023



S1023

Cosmos

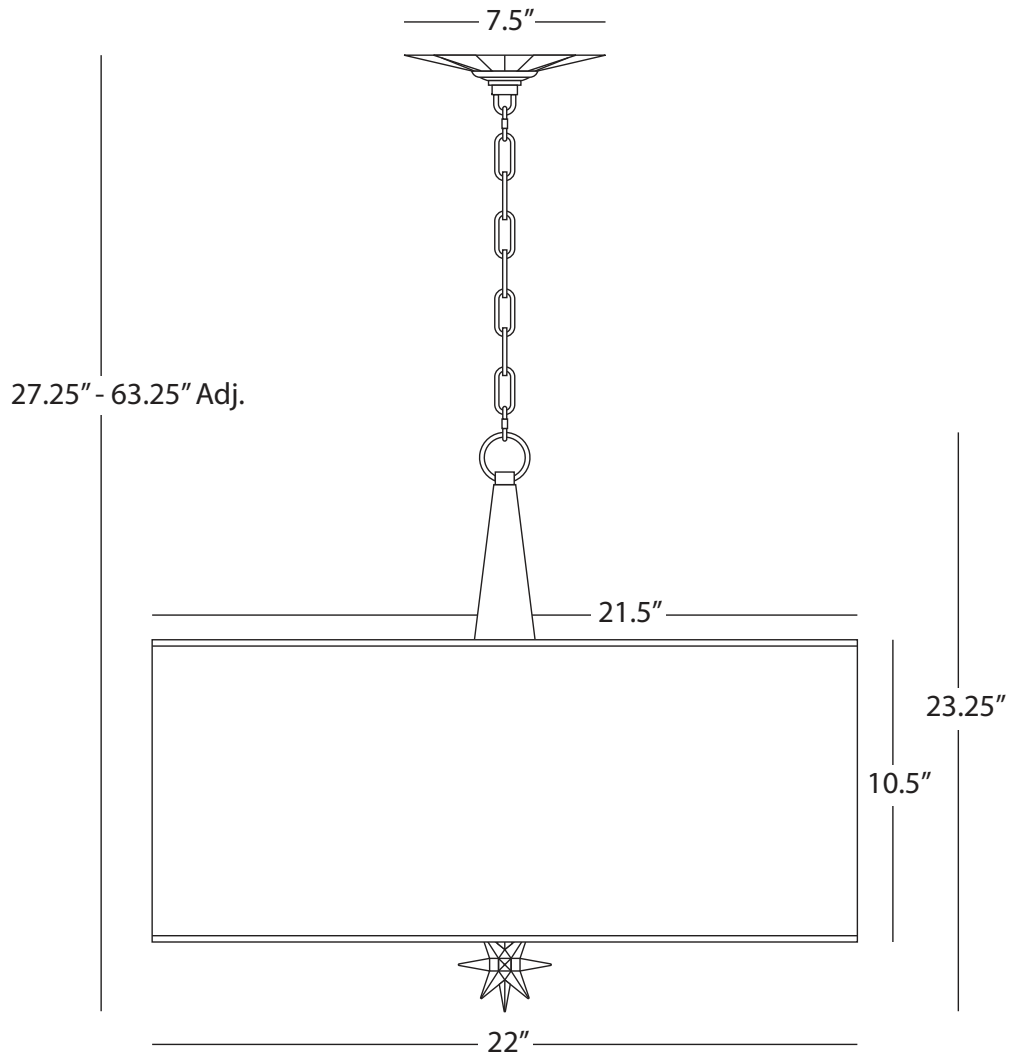

COSMOS

1023

Pendant

3 - 100W Max.

Bulb Type: A

Direct Wire Only

Deep Patina Bronze Finish

Warm Brass Accents

Oyster Linen Shade with Self-Fabric Diffuser

Susp. Hardware: 3 ft. Chain

FINISH OPTIONS:

S1023 Deep Patina Bronze/Antique Silver



625



S625

Cristallo

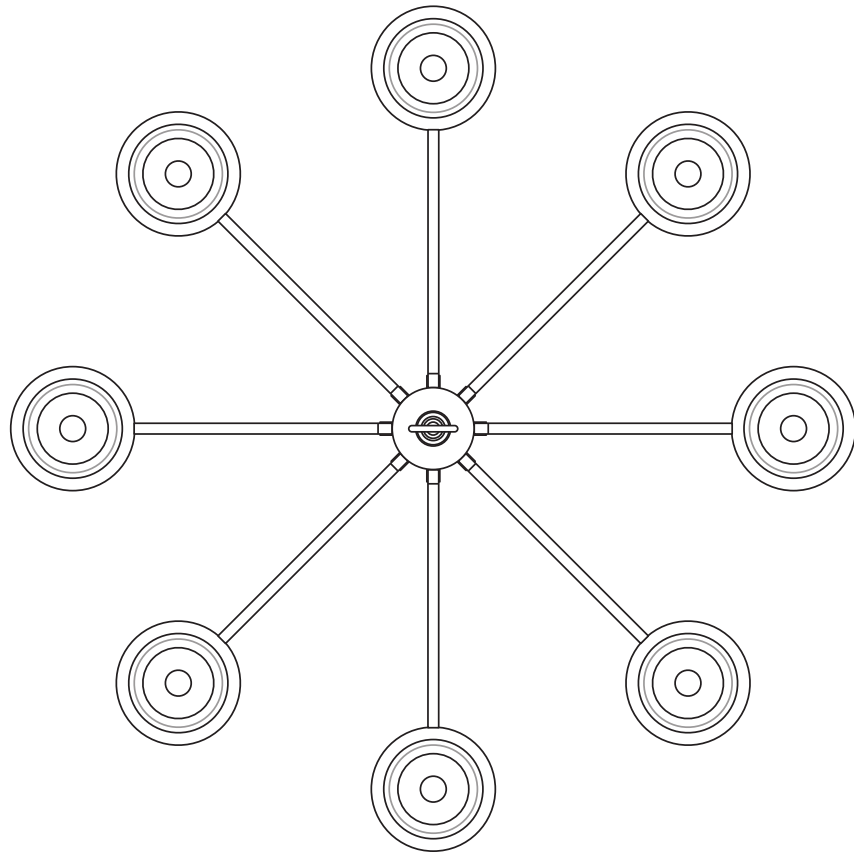

CRISTALLO

625

Chandelier

8 - 60W Max.
Bulb Type: B, Candelabra
Direct Wire
Modern Brass Finish w/
Smoke Crystal Accents
Fondine Fabric Shades
Susp. Hardware: 3 Ft. Chain

FINISH OPTION:

S625 Polished Nickel

— 5.25" —

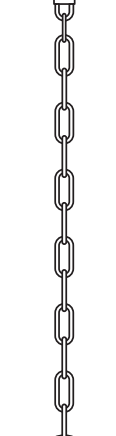

26.25" - 68.25" Adj.

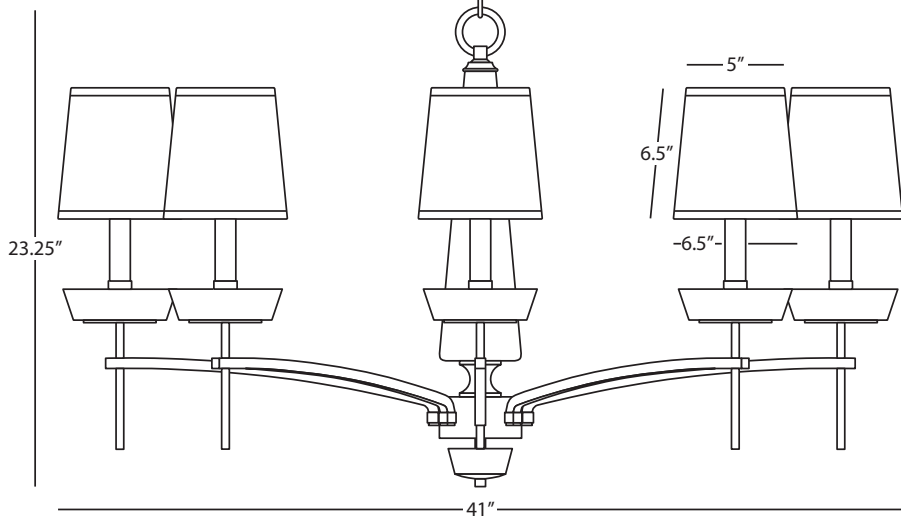

Cristallo



Cristallo



[Click photo above to watch Cristallo video](#)

A modern take on classic candlestick designs, Arthur features tiered tapers and subtle curves that create a timeless and unique look to enhance your space.



629



S609

Cristallo

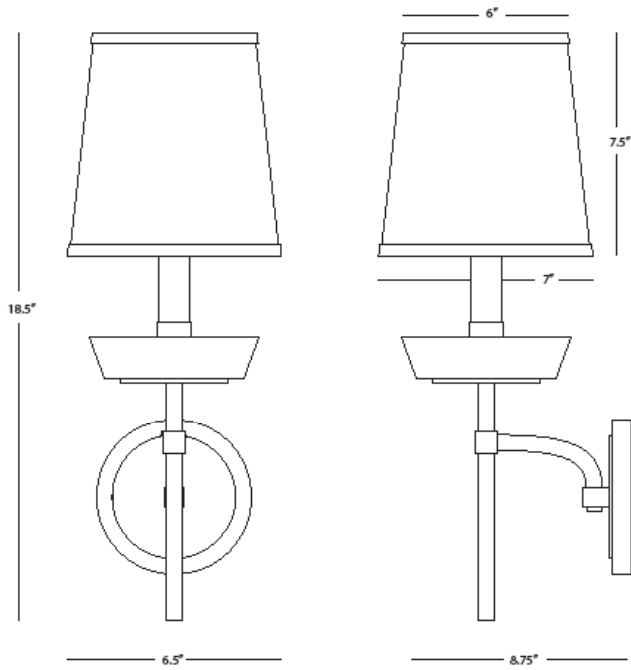

CRISTALLO

629 Wall Sconce

1 - 60W Max.
 Bulb Type: B, Candelabra Base
 Switch: On-Off Line Switch
 24" Cord Cover/Direct Wire
 Modern Brass Finish
 Smoke Crystal Accent
 Fondine Fabric Shade

FINISH OPTIONS:
S629 Polished Nickel

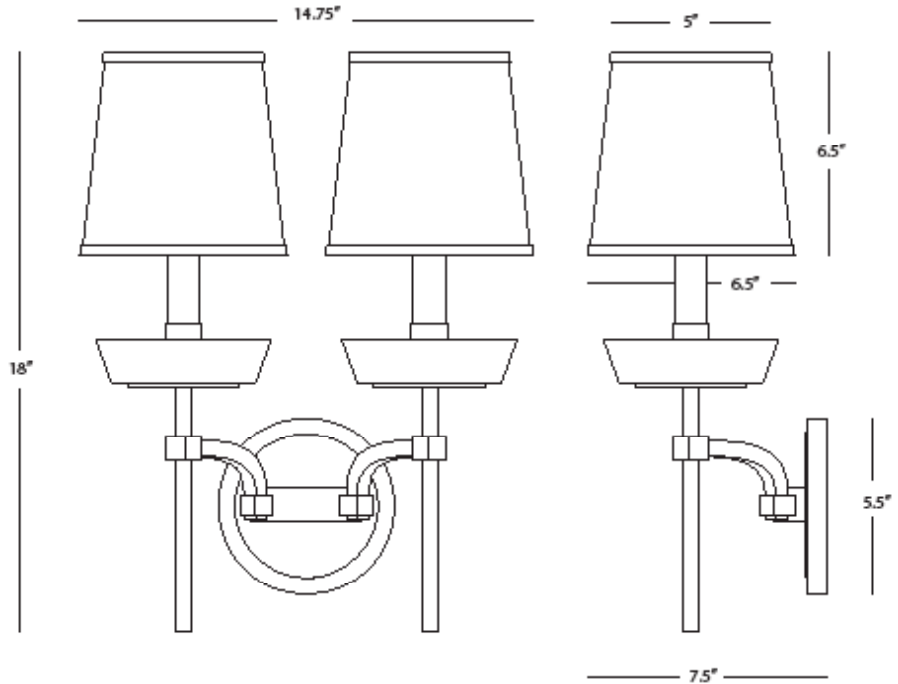

CRISTALLO

S609 Wall Sconce

2 - 60W Max.
 Bulb Type: B, Candelabra Base
 Switch: On-Off Line Switch
 24" Cord Cover/Direct Wire
 Polished Nickel Finish
 Smoke Crystal Accents
 Fondine Fabric Shade

FINISH OPTIONS:
609 Modern Brass



S3609



3608

CURTIS

S3609

Floor Lamp

1 - 100W Max.
 Bulb Type: A
 Switch: Full Range Dimmer Foot Switch
 Deep Patina Bronze Finish
 Dark Antique Nickel Accents
 Oyster Linen Shade

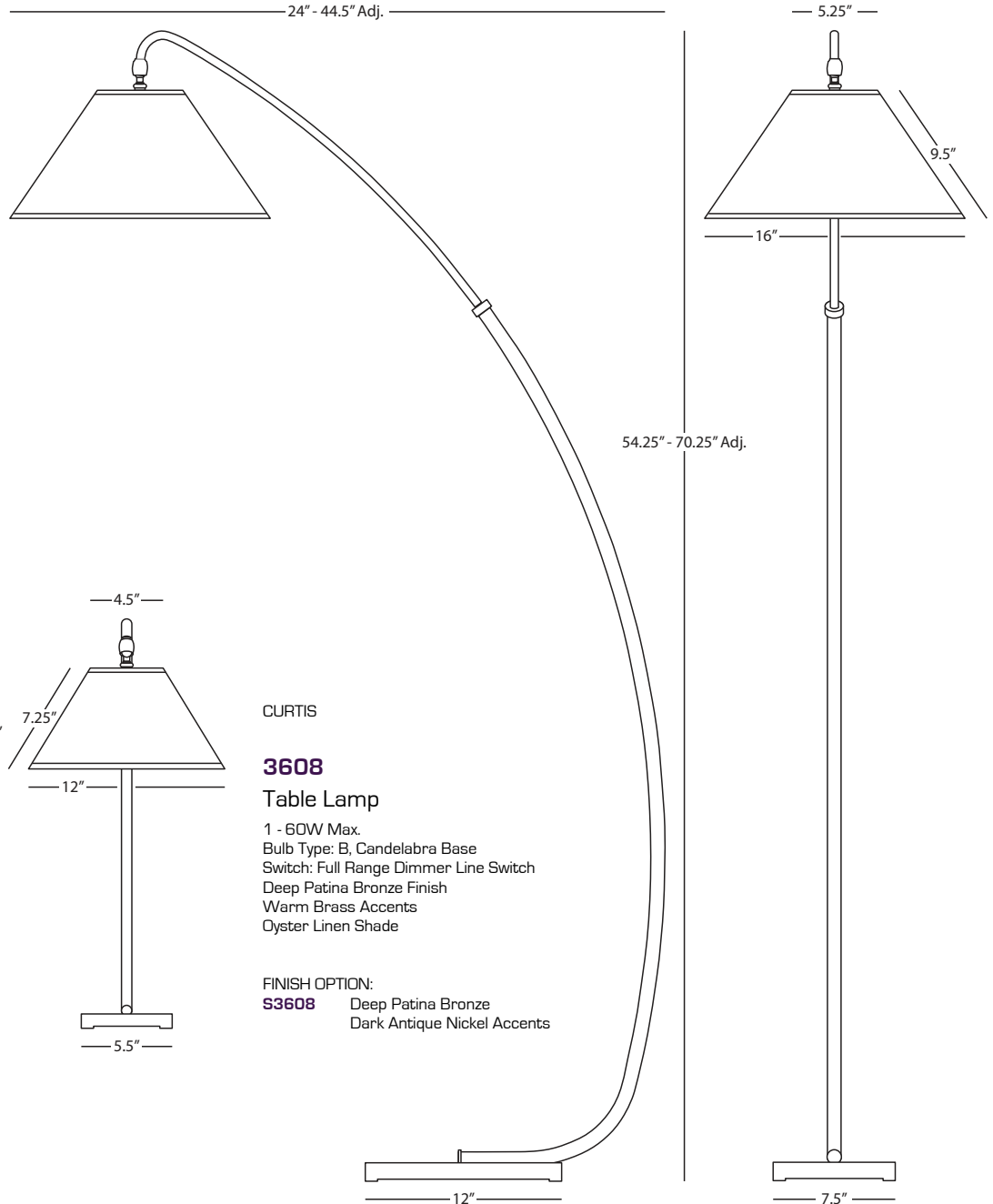

CURTIS

3608

Table Lamp

1 - 60W Max.
 Bulb Type: B, Candelabra Base
 Switch: Full Range Dimmer Line Switch
 Deep Patina Bronze Finish
 Warm Brass Accents
 Oyster Linen Shade

FINISH OPTION:

S3608 Deep Patina Bronze
 Dark Antique Nickel Accents



Z9870



9868



S9869



9871



Z9872

DAL

Z9870

Vessel Accent Lamp

1 - 100W Max.
 Bulb Type: A
 Switch: Hi-Lo Dimming
 Hammered Metal Base
 Deep Patina Bronze Finish
 Oyster Linen Shade

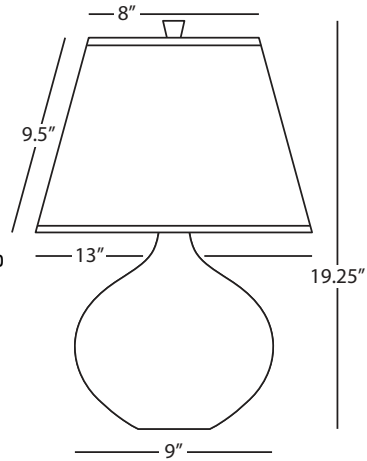

FINISH OPTIONS:

- 9870** Modern Brass
- S9870** Polished Nickel

DAL

9871

Vessel Table Lamp

1 - 150W Max.
 Bulb Type: A
 Switch: Hi-Lo Dimming
 Hammered Metal Base
 Modern Brass Finish
 Oyster Linen Shade

FINISH OPTIONS:

- S9871** Polished Nickel
- Z9871** Deep Patina Bronze

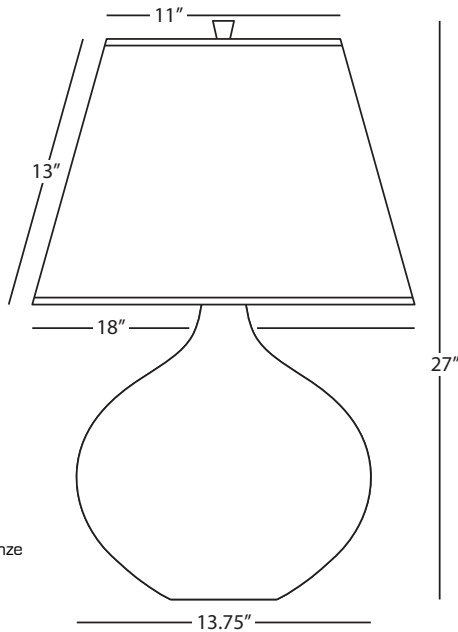

DAL

9868

Tapered Accent Lamp

1 - 150W Max.
 Bulb Type: A
 Switch: Hi-Lo Dimming
 Hammered Metal Base
 Modern Brass Finish
 Oyster Linen Shade

FINISH OPTIONS:

- S9868** Polished Nickel
- Z9868** Deep Patina Bronze

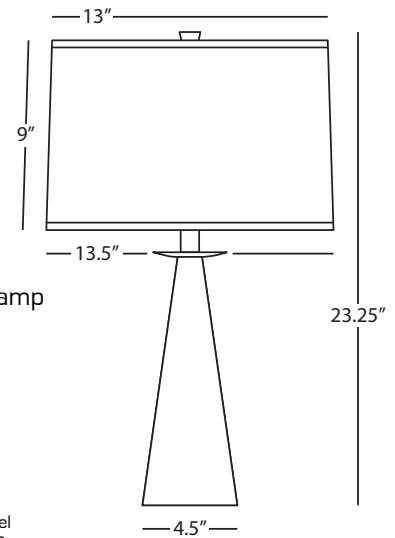

DAL

Z9872

Tapered Square Table Lamp

1 - 150W Max.
 Bulb Type: A
 Switch: Hi-Lo Dimming
 Hammered Metal Base
 Deep Patina Bronze Finish
 Oyster Linen Shade

FINISH OPTIONS:

- 9872** Modern Brass
- S9872** Polished Nickel

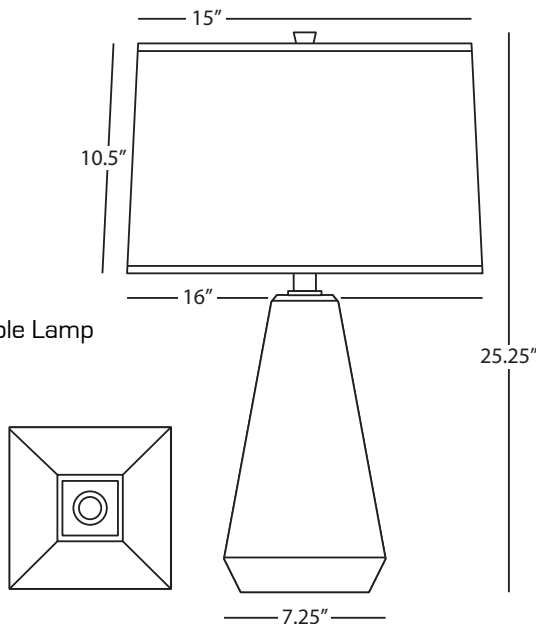

DAL

S9869

Tapered Table Lamp

1 - 150W Max.
 Bulb Type: A
 Switch: Hi-Lo Dimming
 Hammered Metal Base
 Polished Nickel Finish
 Oyster Linen Shade

FINISH OPTIONS:

- 9869** Modern Brass
- Z9869** Deep Patina Bronze

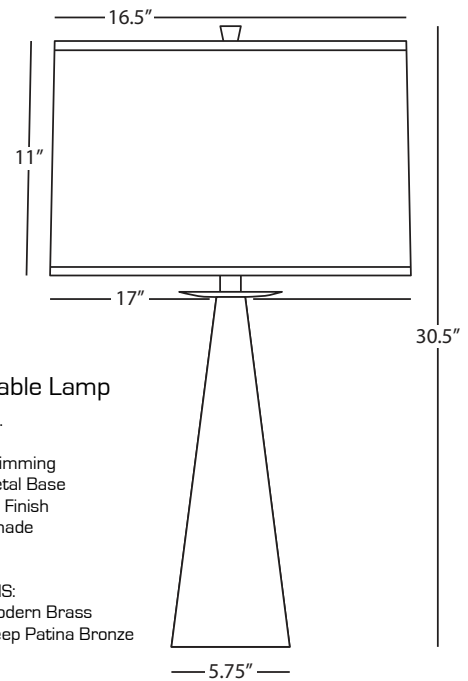

| Dal

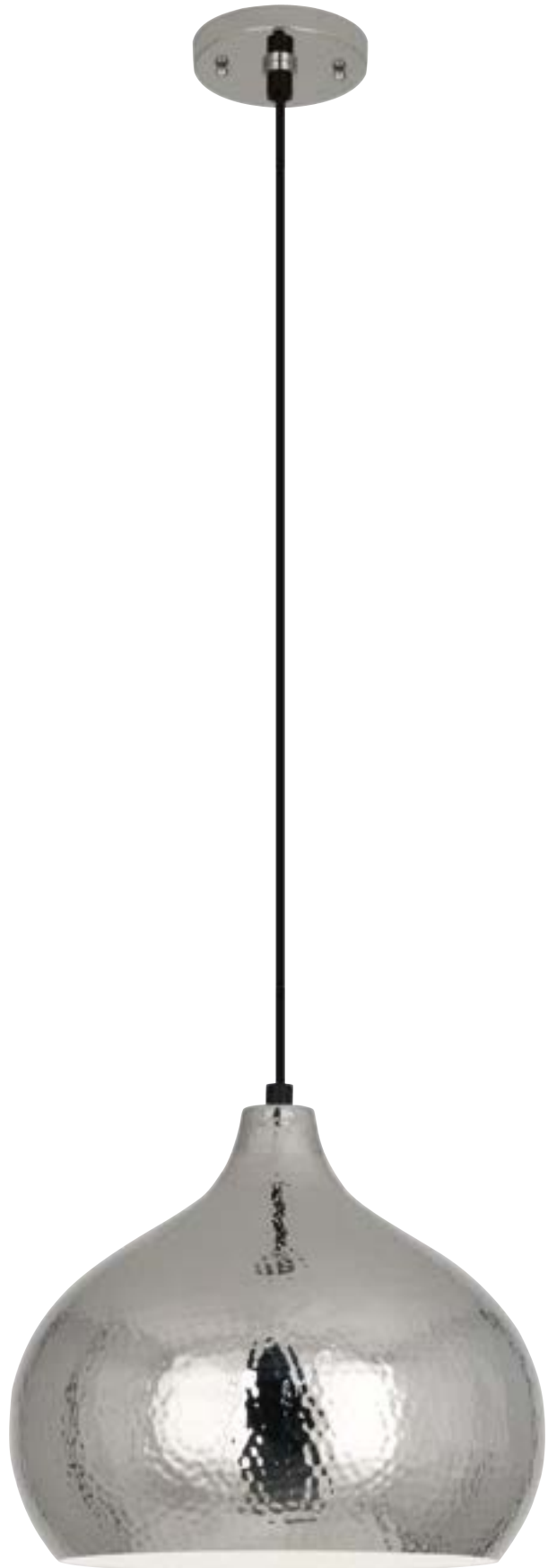

Dal

[Click photo above to watch Dal Dome Pendant Video](#)

Elegant tapers, curves, and hammered metal finishes give Dal a sophisticated and stylish quality that draws the eye and creates a warm, inviting ambiance!

Dal



Dal

[Click photo above to watch Dal Tapered Pendant Video](#)

Elegant tapers, curves, and hammered metal finishes give Dal a sophisticated and stylish quality that draws the eye and creates a warm, inviting ambiance!



9873



S9873



Z9873



S9874



Z9874



9874

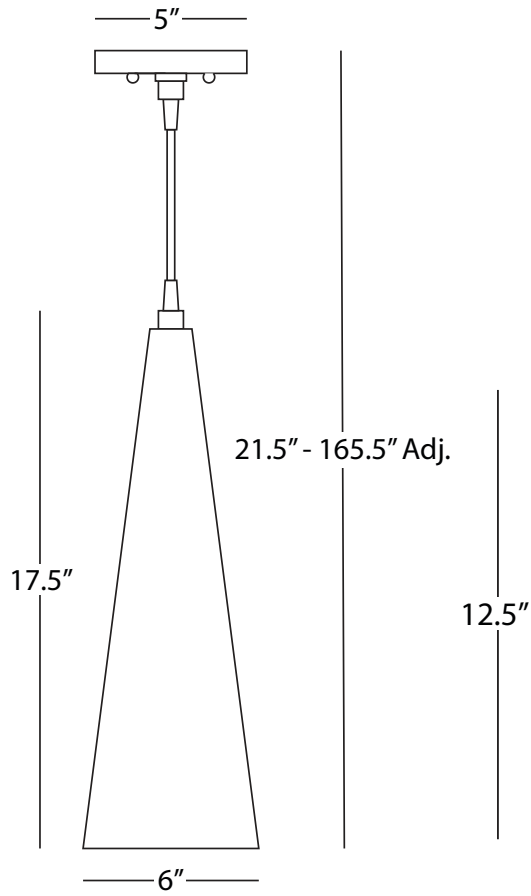

Dal

9873

Tapered Pendant

1- 60W Max.
 Bulb Type: A
 Direct Wire Only
 Modern Brass Finish
 Metal Shade
 Black Fabric Wrapped Cord

FINISH OPTIONS:

S9873 Polished Nickel
Z9873 Deep Patina Bronze

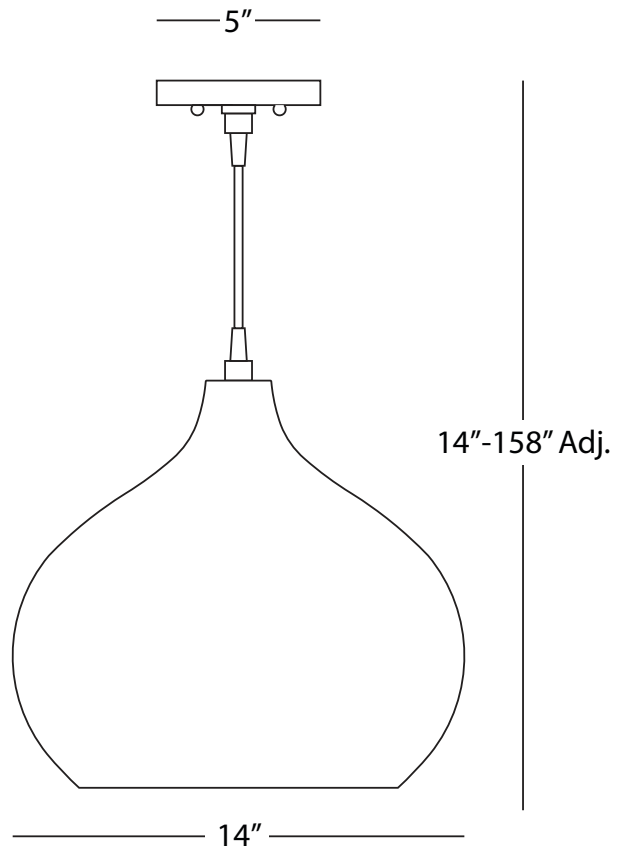

Dal

S9874

Dome Pendant

1- 60W Max.
 Bulb Type: A
 Direct Wire Only
 Polished Nickel Finish
 Metal Shade
 Black Fabric Wrapped Cord

FINISH OPTIONS:

9874 Modern Brass
Z9874 Deep Patina Bronze

Dal

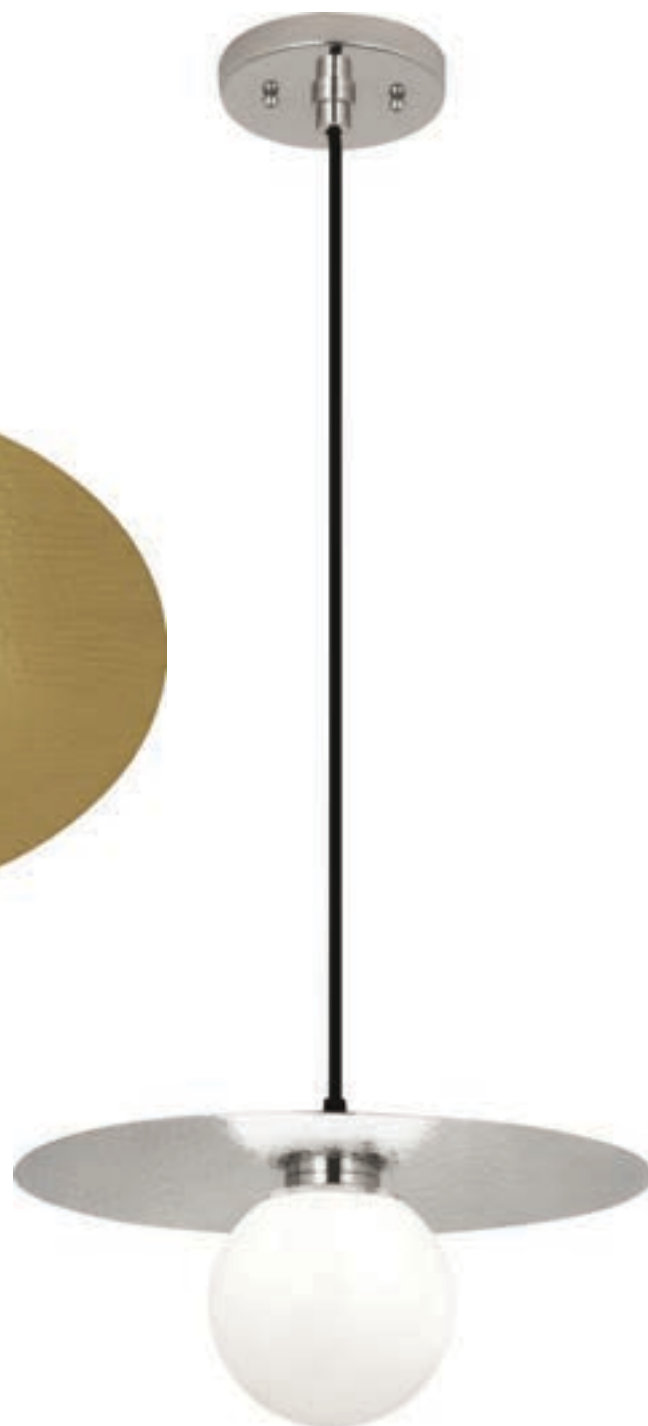

Dal



[Click photo above to watch Dal video](#)

A modern take on classic candlestick designs, Arthur features tiered tapers and subtle curves that create a timeless and unique look to enhance your space.



S9875



Z9876

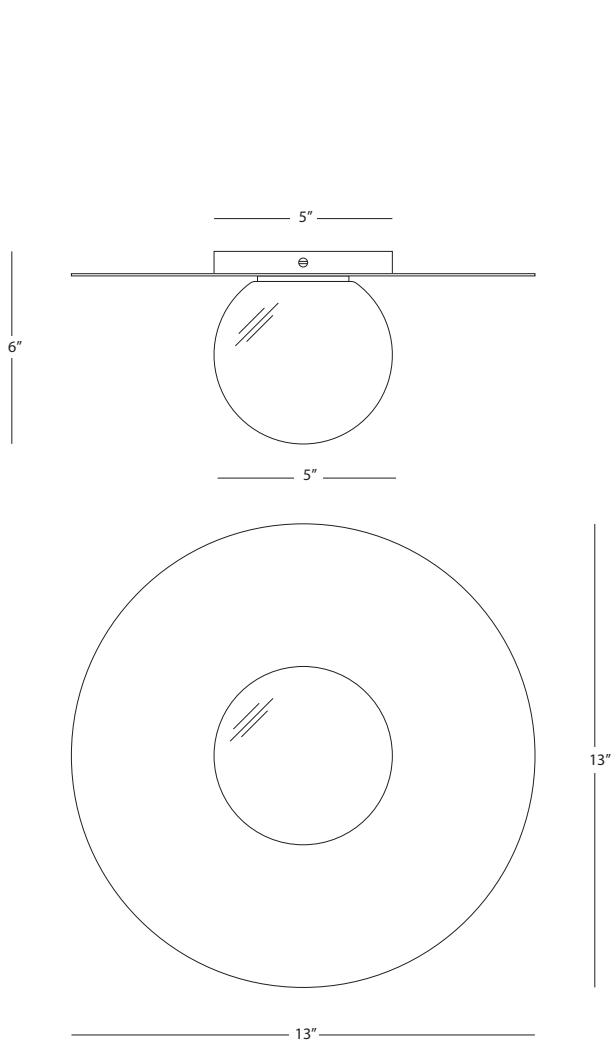

DAL

S9875
Flush Mount

1 - 4W Max.
Bulb Type: 120V G9, Bi-Pen LED
Direct Wire Only
Polished Nickel Finish
White Glass Shade
UL Rated Damp Locations

FINISH OPTIONS:

9875 Modern Brass
Z9875 Deep Patina Bronze

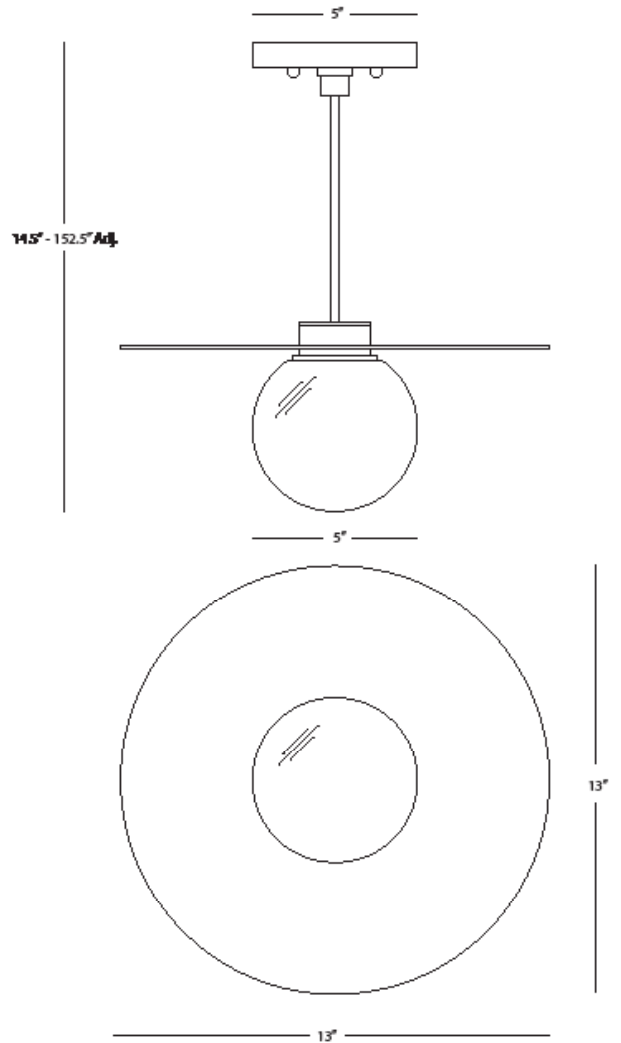

DAL

Z9876
Pendant

1 - 4W Max.
Bulb Type: 120V G9, Bi-Pen LED
Direct Wire Only
Deep Patina Bronze Finish
White Glass Shade
UL Rated Damp Locations

FINISH OPTIONS:

9876 Modern Brass
S9876 Polished Nickel



C6900



6900



S6900



B6900



Z6900

Daphne

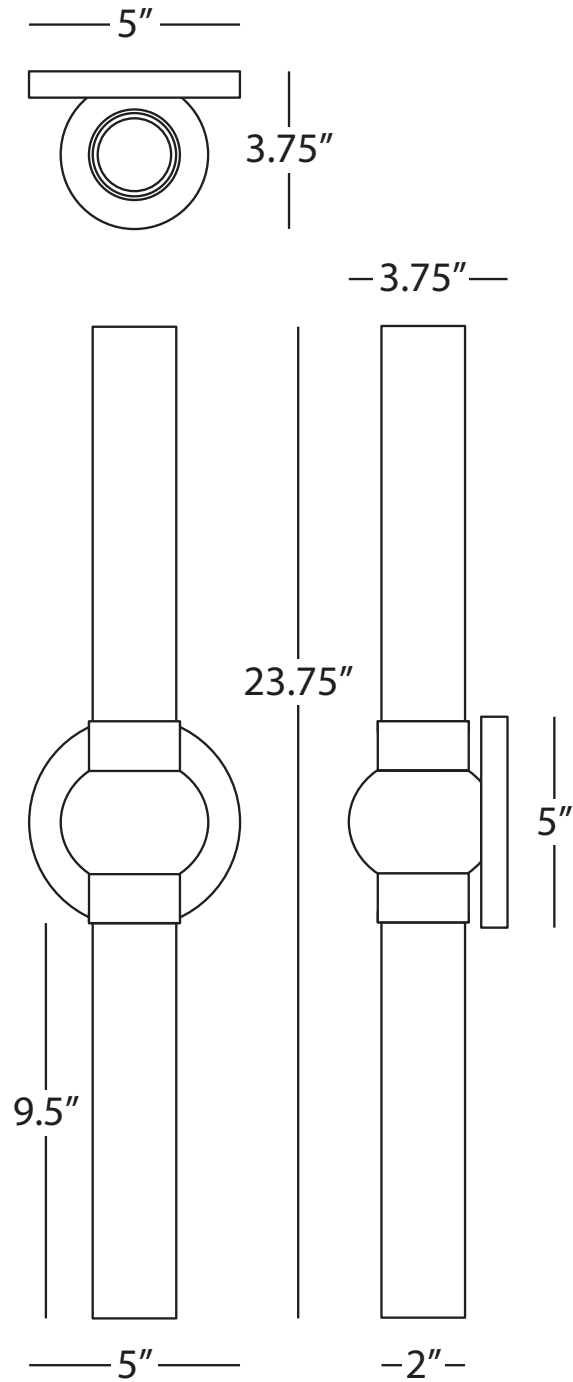

DAPHNE

6900

Wall Sconce

2 - 10W Max.

(1600 Lumen Output)

Bulb Type: LED unit, Included (Non-Replaceable)

LED Color Temp: 3000, CRI: 90

Direct Wire Only

Modern Brass Finish

Cased White Frosted Glass Shades

UL Rated for Damp Locations

ADA Compliant

FINISH OPTIONS:

B6900 Antique Silver

C6900 Chrome

S6900 Polished Nickel

Z6900 Deep Patina Bronze



AW137



PG138



RB137



SG137



VW138

Decker

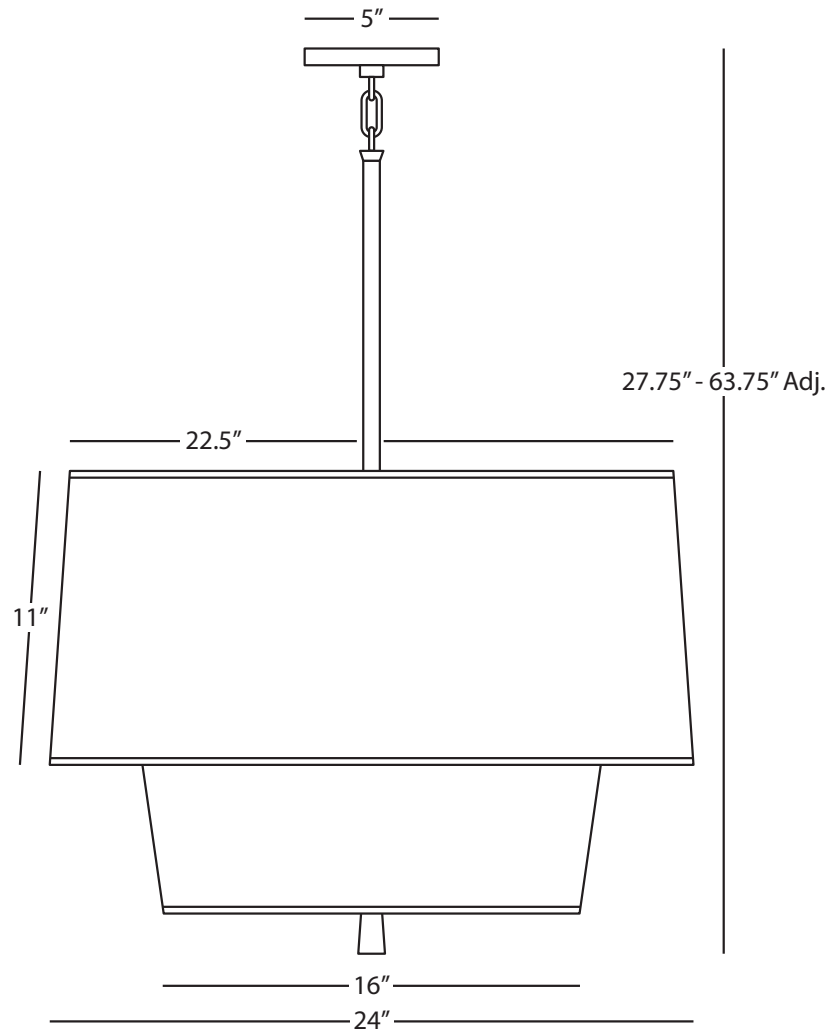

DECKER

AW137

Two-Tier Pendant

3 - 100W Max.
Bulb Type: A
Direct Wire
Modern Brass Finish
Two-Tier Ascot White Fabric Shade
14.5" Dia. White Acrylic Diffuser
Susp. Hardware: 1 pc. 5/8" x 6" & 3 pcs.
5/8" x 12" Extensions

FINISH/SHADE OPTIONS:

PG137	Modern Brass/Pearl Gray
RB137	Modern Brass/Raven Black
SG137	Modern Brass/Smoke Gray
VW137	Modern Brass/Vintage Wine
AW138	Polished Nickel/Ascot White
PG138	Polished Nickel/Pearl Gray
RB138	Polished Nickel/Raven Black
SG138	Polished Nickel/Smoke Gray
VW138	Polished Nickel/Vintage Wine

| Decker



Decker

[Click photo above to watch Decker Wide Two-Tier Pendant Video](#)

The Decker collection features nested fabric shades that create a warm and inviting atmosphere. Decker comes in a variety of size and color options to accommodate your space perfectly.

Decker



Decker

[Click photo above to watch Decker Three-Tier Pendant Video](#)

The Decker collection features nested fabric shades that create a warm and inviting atmosphere. Decker comes in a variety of size and color options to accommodate your space perfectly.



AW140



SG141

Decker

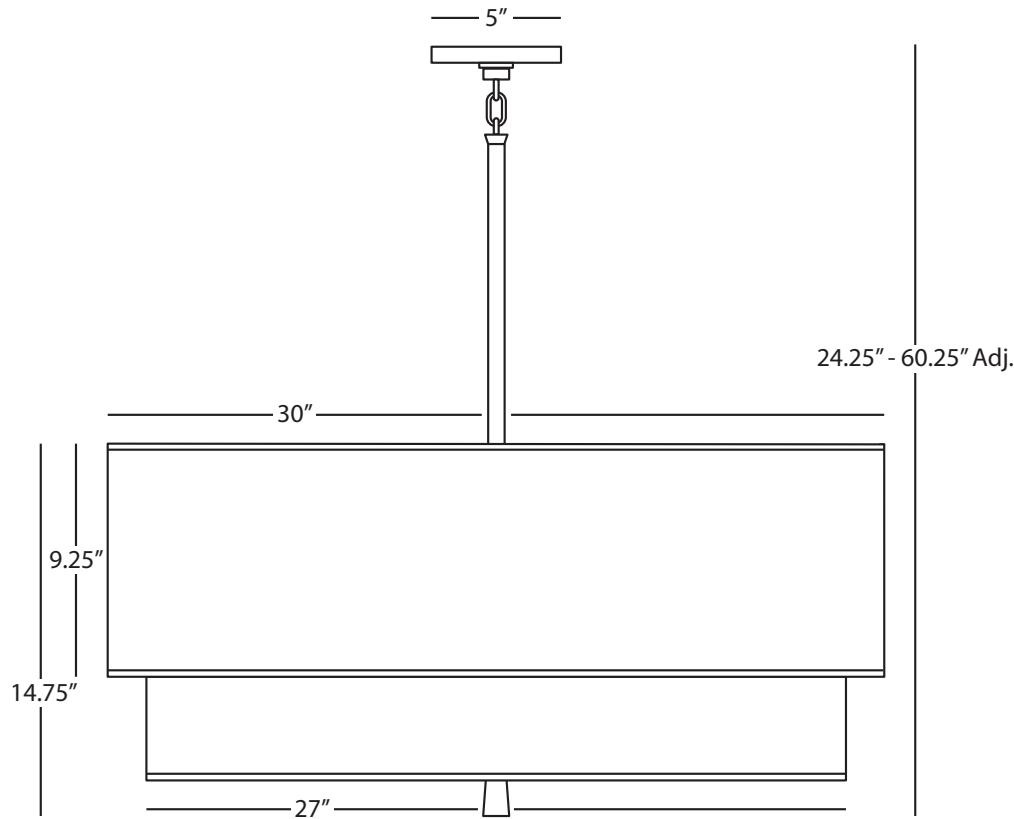

DECKER

AW140

Wide Two-Tier Pendant

3 - 100W Max.
 Bulb Type: A
 Direct Wire
 Polished Nickel Finish
 Wide Two-Tier Ascot White Fabric Shade
 26.25" Dia. White Acrylic Diffuser
 Susp. Hardware: 1 pc. 5/8" x 6" & 3 pcs. 5/8" x 12" Extensions

FINISH/SHADE OPTIONS:

AW139 Modern Brass/Ascot White
PG139 Modern Brass/Pearl Gray
RB139 Modern Brass/Raven Black
SG139 Modern Brass/Smoke Gray
VW139 Modern Brass/Vintage Wine
PG140 Polished Nickel/Pearl Gray
RB140 Polished Nickel/Raven Black
SG140 Polished Nickel/Smoke Gray
VW140 Polished Nickel/Vintage Wine

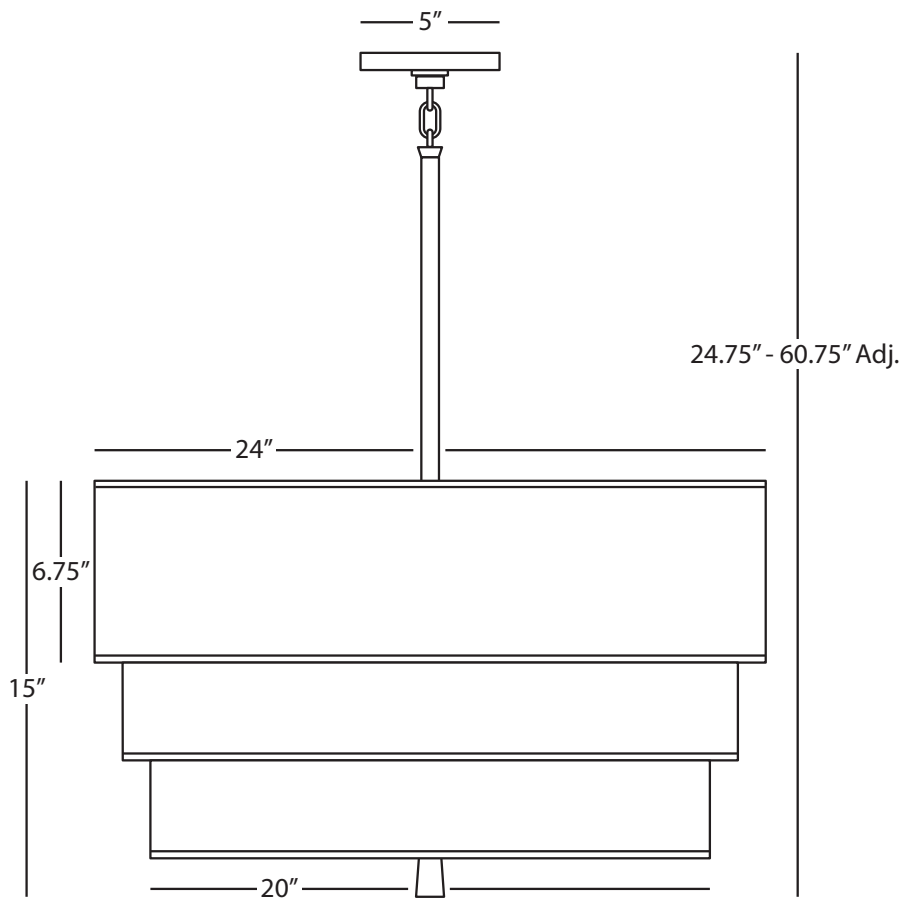

DECKER

SG141

Three-Tier Pendant

3 - 100W Max.
 Bulb Type: A
 Direct Wire
 Modern Brass Finish
 Three-Tier Smoke Gray Fabric Shade
 19.25" Dia. White Acrylic Diffuser
 Susp. Hardware: 1 pc. 5/8" x 6" & 3 pcs. 5/8" x 12" Extensions

FINISH/SHADE OPTIONS:

AW141 Modern Brass/Ascot White
PG141 Modern Brass/Pearl Gray
RB141 Modern Brass/Raven Black
VW141 Modern Brass/Vintage Wine
AW142 Polished Nickel/Ascot White
PG142 Polished Nickel/Pearl Gray
RB142 Polished Nickel/Raven Black
SG142 Polished Nickel/Smoke Gray
VW142 Polished Nickel/Vintage Wine

| Decker



Decker

[Click photo above to watch Decker Flush Mount video](#)

The Decker collection features nested fabric shades that create a warm and inviting atmosphere. Decker comes in a variety of size and color options to accommodate your space perfectly.



AW143



PG144



SG143



RB143



VW144

Decker

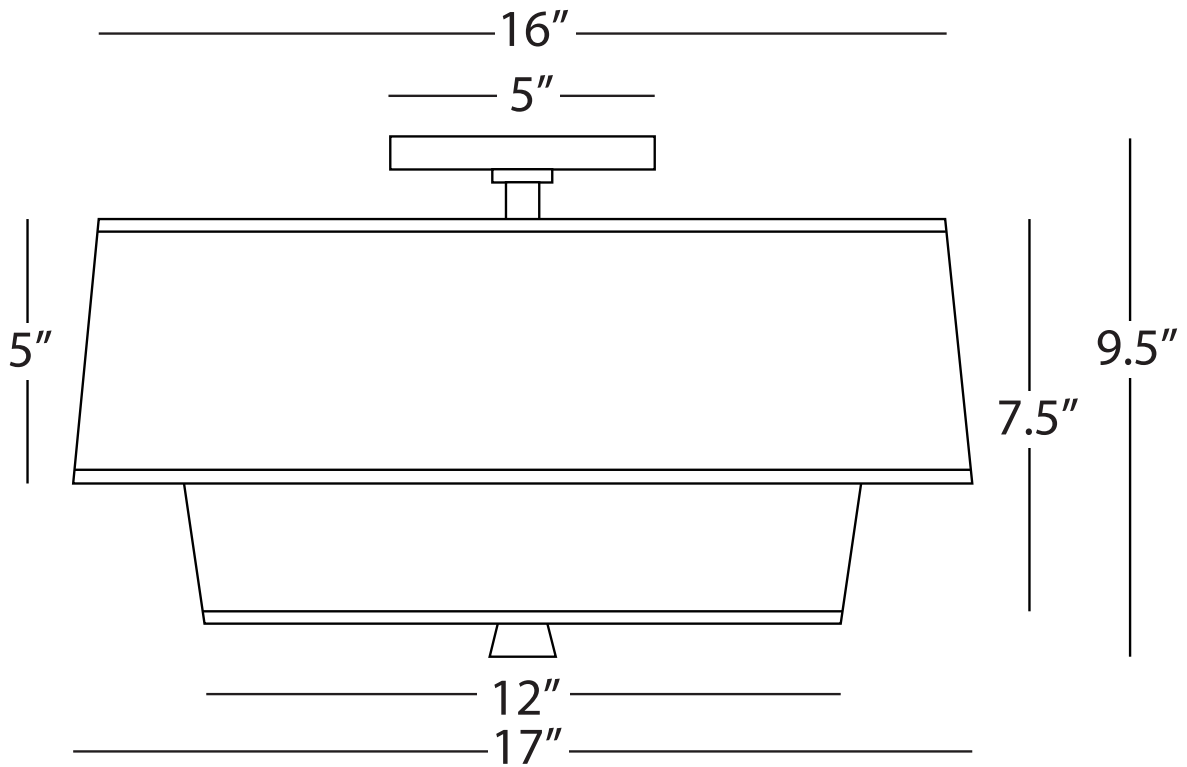

DECKER

AW143

Flush Mount

2 - 60W Max.

Bulb Type: A

Direct Wire

Modern Brass Finish

Two-Tier Ascot White Fabric Shade

11.75" Dia. White Acrylic Diffuser

FINISH/SHADE OPTIONS:

PG143	Modern Brass/Pearl Gray
RB143	Modern Brass/Raven Black
SG143	Modern Brass/Smoke Gray
VW143	Modern Brass/Vintage Wine
AW144	Polished Nickel/Ascot White
PG144	Polished Nickel/Pearl Gray
RB144	Polished Nickel/Raven Black
SG144	Polished Nickel/Smoke Gray
VW144	Polished Nickel/Vintage Wine

Decker



Decker

[Click photo above to watch Decker Table Lamp Video](#)

The Decker collection features nested fabric shades that create a warm and inviting atmosphere. Decker comes in a variety of size and color options to accommodate your space perfectly.

Decker



Decker

[Click photo above to watch Decker Floor Lamp Video](#)

The Decker collection features nested fabric shades that create a warm and inviting atmosphere. Decker comes in a variety of size and color options to accommodate your space perfectly.



PG133



AW130

Decker

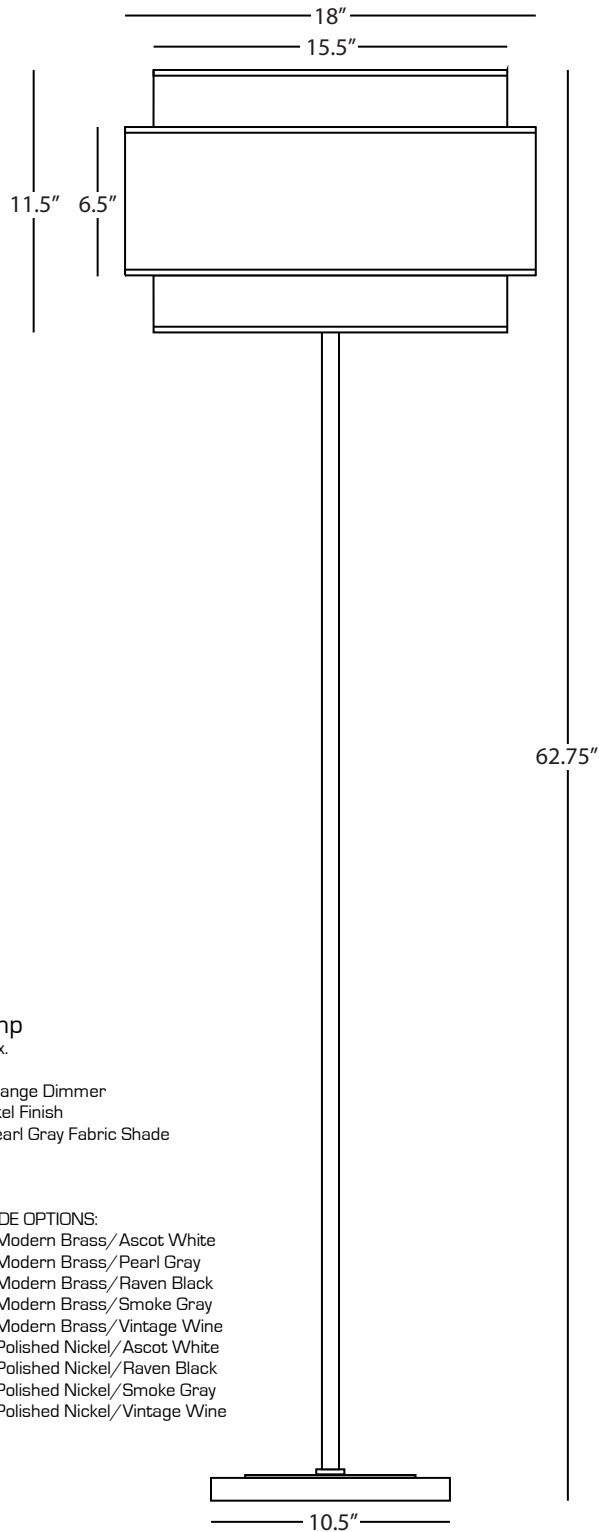

DECKER

PG133

Floor Lamp

1-150W Max.

Bulb Type: A

Switch: Full Range Dimmer

Polished Nickel Finish

Three-Tier Pearl Gray Fabric Shade

FINISH/SHADE OPTIONS:

AW132	Modern Brass/Ascot White
PG132	Modern Brass/Pearl Gray
RB132	Modern Brass/Raven Black
SG132	Modern Brass/Smoke Gray
VW132	Modern Brass/Vintage Wine
AW133	Polished Nickel/Ascot White
RB133	Polished Nickel/Raven Black
SG133	Polished Nickel/Smoke Gray
VW133	Polished Nickel/Vintage Wine

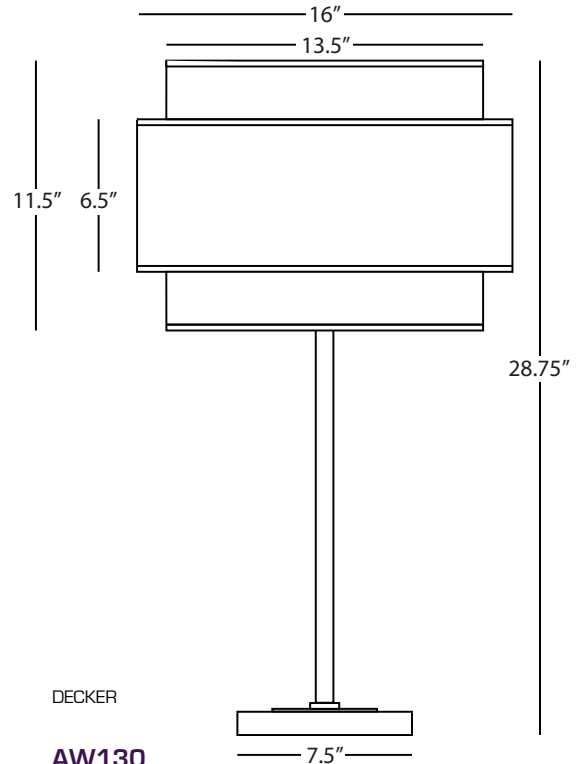

DECKER

AW130

Table Lamp

1-150W Max.

Bulb Type: A

Switch: Full Range Dimmer

Modern Brass Finish

Three-Tier Ascot White Fabric Shade

FINISH/SHADE OPTIONS:

PG130	Modern Brass/Pearl Gray
RB130	Modern Brass/Raven Black
SG130	Modern Brass/Smoke Gray
VW130	Modern Brass/Vintage Wine
AW131	Polished Nickel/Ascot White
PG131	Polished Nickel/Pearl Gray
RB131	Polished Nickel/Raven Black
SG131	Polished Nickel/Smoke Gray
VW131	Polished Nickel/Vintage Wine



4500

Delany

DELANY

4500 Chandelier

8 - 60W Max.
Bulb Type: B, Candelabra
1 - 35W Max. for Downlight
Bulb Type: GU10 MR16 Halogen
Direct Wire
Antique Brass Finish
Susp. Hardware: 1 pc. 5/8" x 6"
& 3 pcs. 5/8" x 12" Extensions

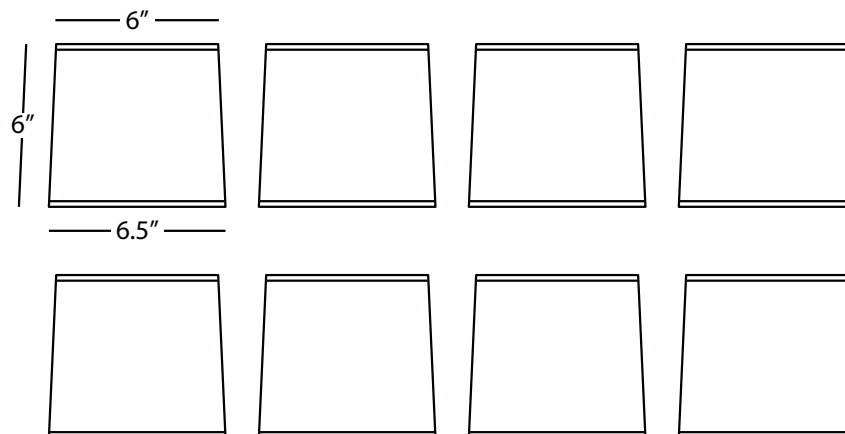
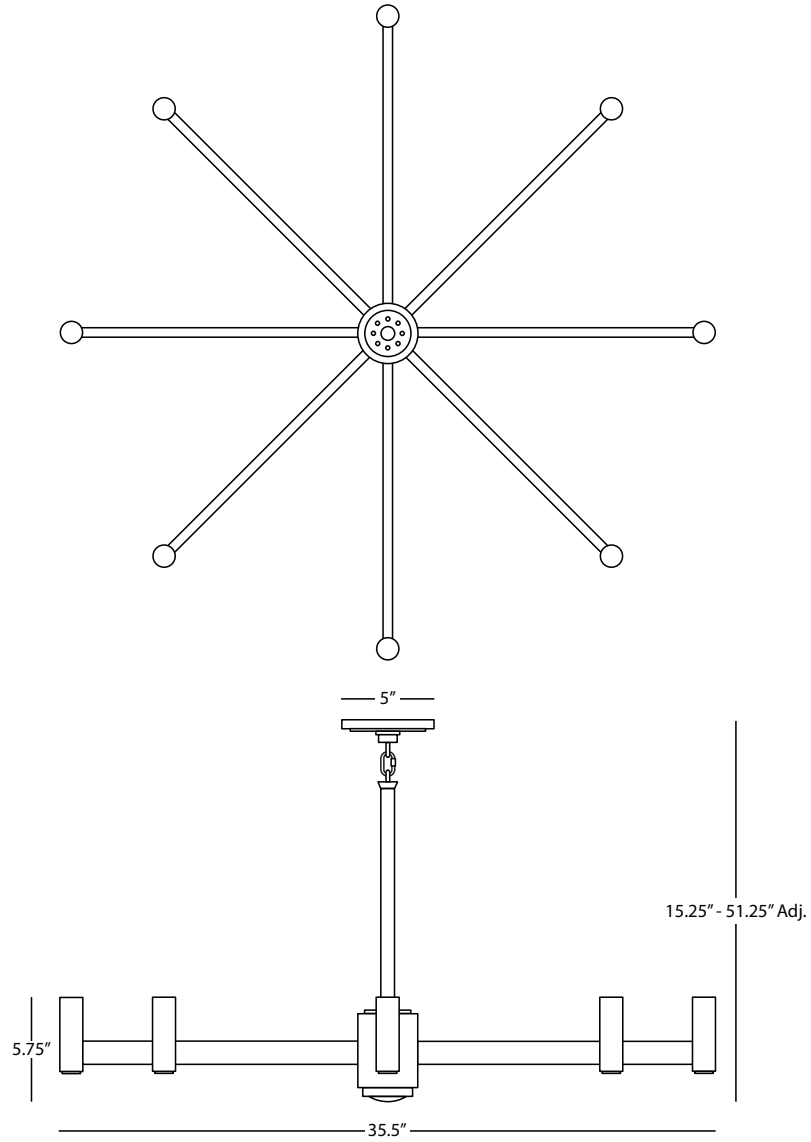

DELANY

4500N Shades Only

Oyster Linen Shades
Nickel Candle Followers
QTY: 8

FINISH OPTION:

4500B Brass Candle Followers



BN701



ML701



MB701



EB701

Delilah

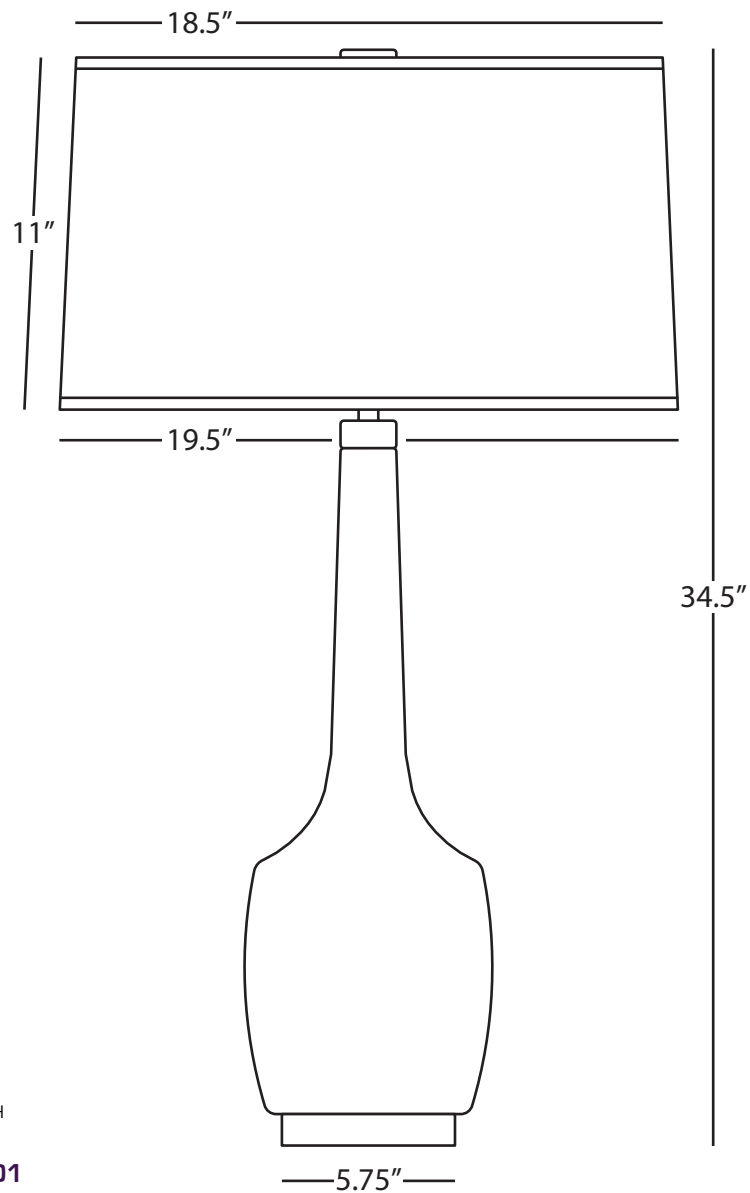

DELILAH

BN701

Table Lamp

1 - 150W Max.
Bulb Type: A
Switch: Hi-Lo Dimming
Bone Glazed Ceramic
Antique Brass Finish
Oyster Linen Shade w/ Self-Fabric
Top and Bottom Diffuser

See Page 496 for Color Options



941



935



G930



946



942



MB930

DELTA

935

Table Lamp

1 - 150W Max.
Bulb Type: A
Switch: 3-Way
Apple Glazed Ceramic
Polished Nickel Accents
Oyster Linen Shade

See Page 296 for Color Options available w/ Oyster Linen Shade

FINISH/SHADE OPTION:

G930 Polished Gold Glazed Ceramic w/
Polished Brass Accents
White Ceramic Parchment Shade w/ Gold Mylar Lining

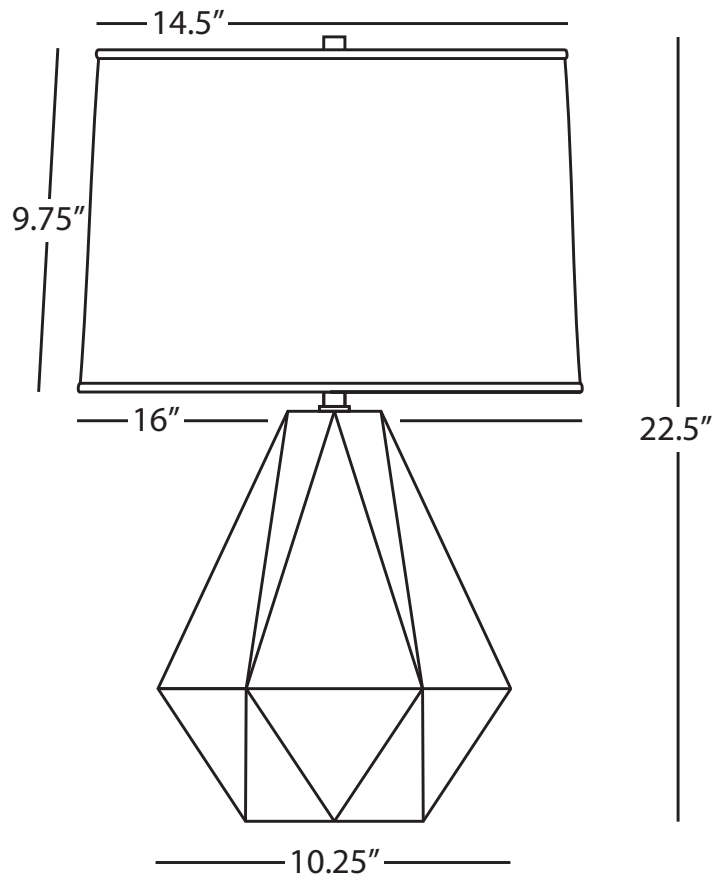
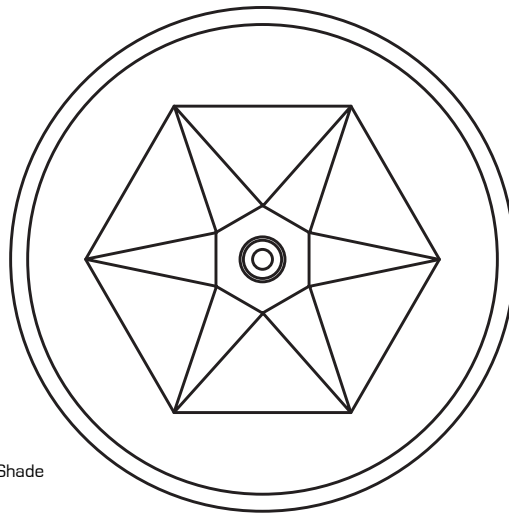



S206



205

Dexter

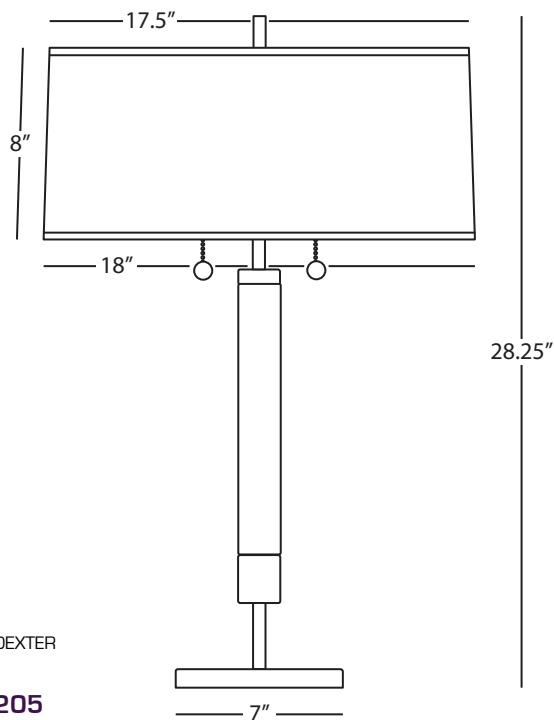

DEXTER

205 Table Lamp

2 - 100W Max.
Bulb Type: A
Switch: On-Off Pull Chains
Modern Brass Finish
Walnut Finished Wood Column
Oyster Linen Shade

FINISH OPTION:

S205 Polished Nickel/Dark Walnut Column

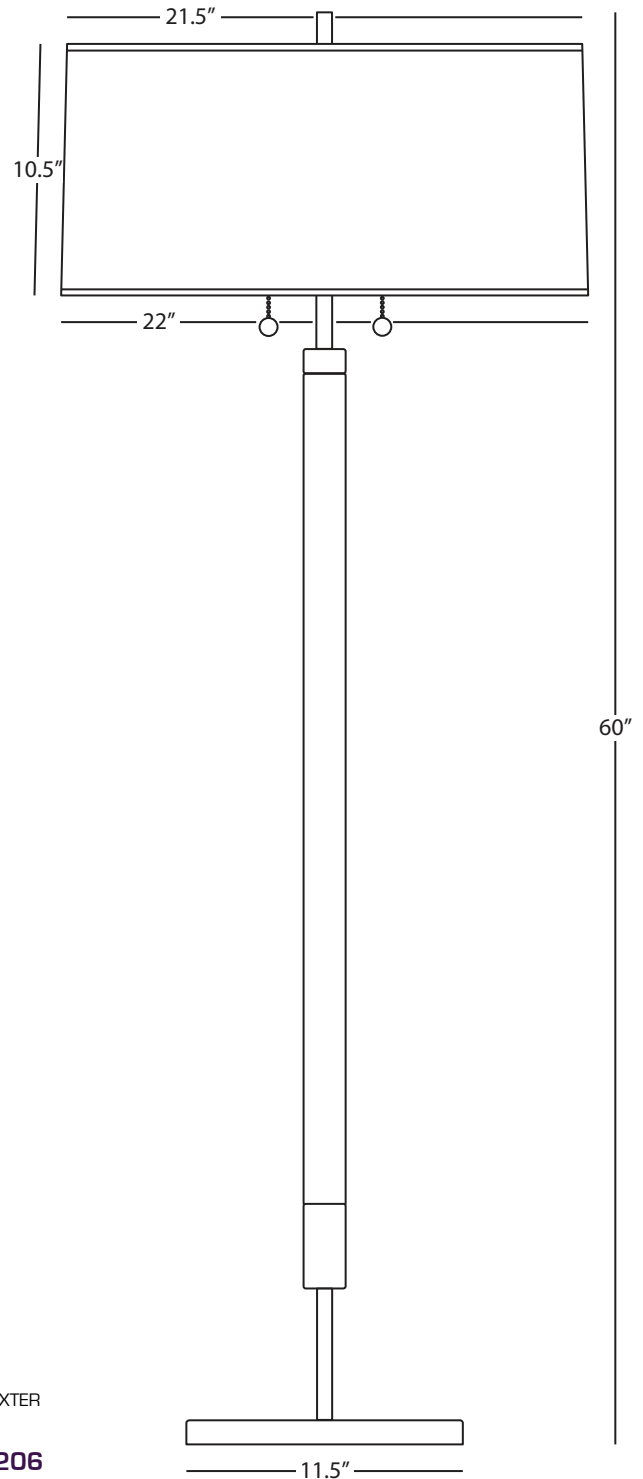

DEXTER

S206 Floor Lamp

2 - 100W Max.
Bulb Type: A
Switch: On-Off Pull Chains
Polished Nickel Finish
Dark Walnut Finished Wood Column
Oyster Linen Shade

FINISH OPTION:

206 Modern Brass/Walnut Column



204



S204

Diana

DIANA

204

Pendant

8 - 60W Max.
Bulb Type: B, Candelabra
Direct Wire
Warm Brass Finish w/
Antiqued Mirror Accents
Susp. Hardware: 3 Ft. Chain

FINISH OPTION:
S204 Antique Silver

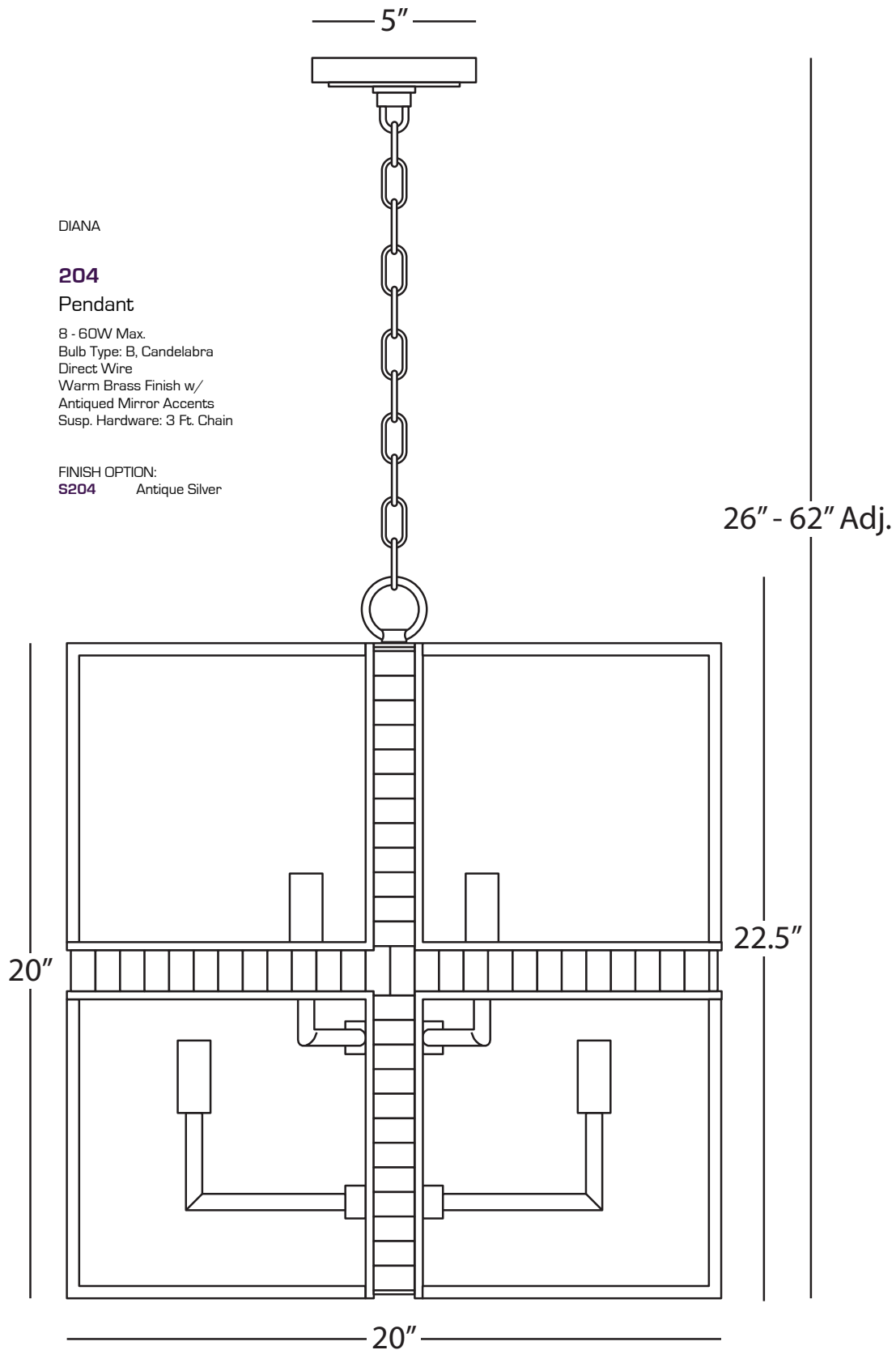



Z1547



Z1546

Director

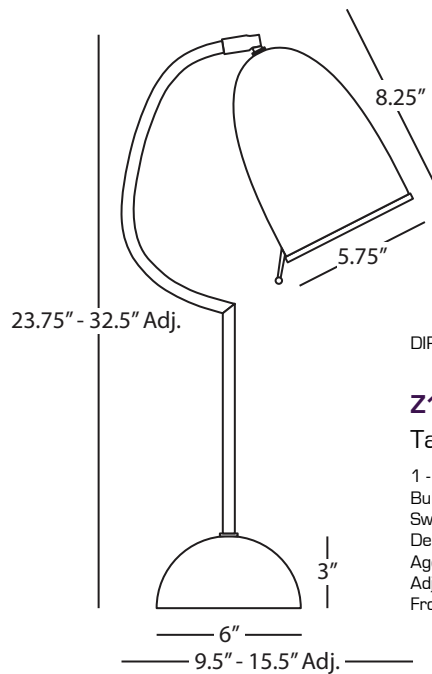
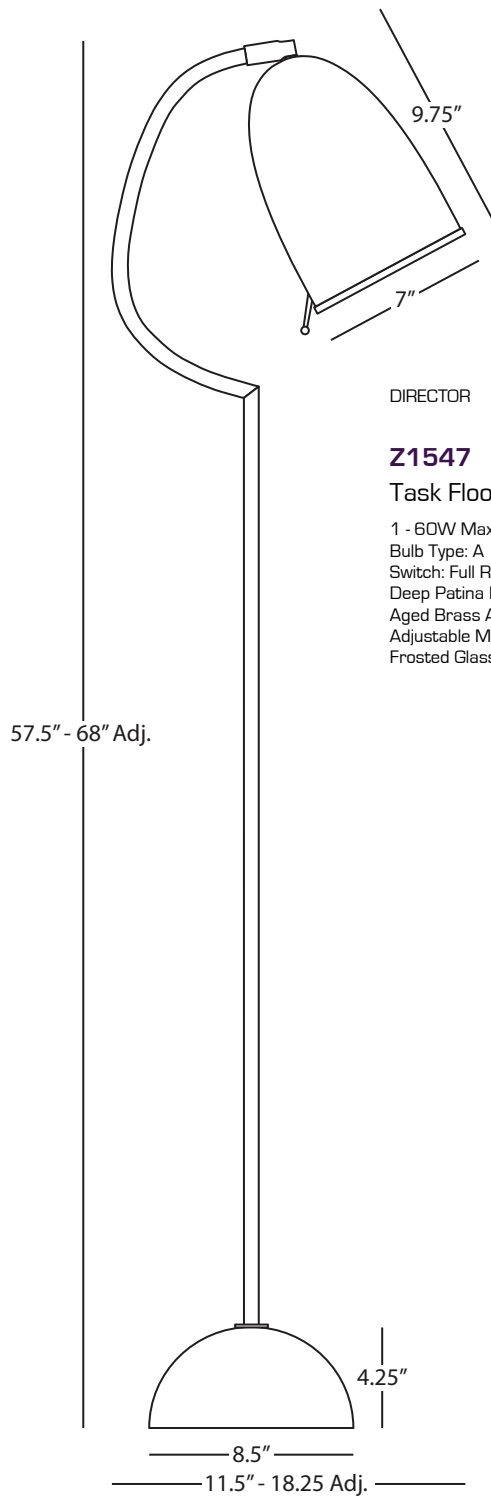



BN801



AM801



BB801



PC800

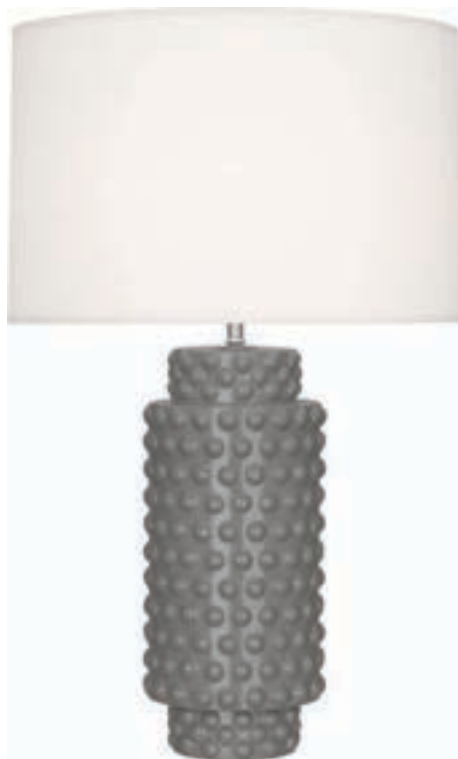

ST800



MB800

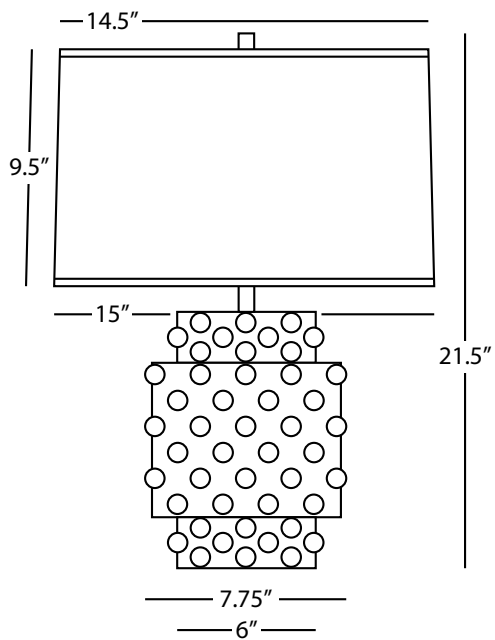

DOLLY

AM801

Accent Lamp

1 - 150W Max.
 Bulb Type: A
 Switch: Full Range Dimmer
 Amethyst Glazed Textured Ceramic
 Fondine Fabric Shade

See Page 497 for Color Options

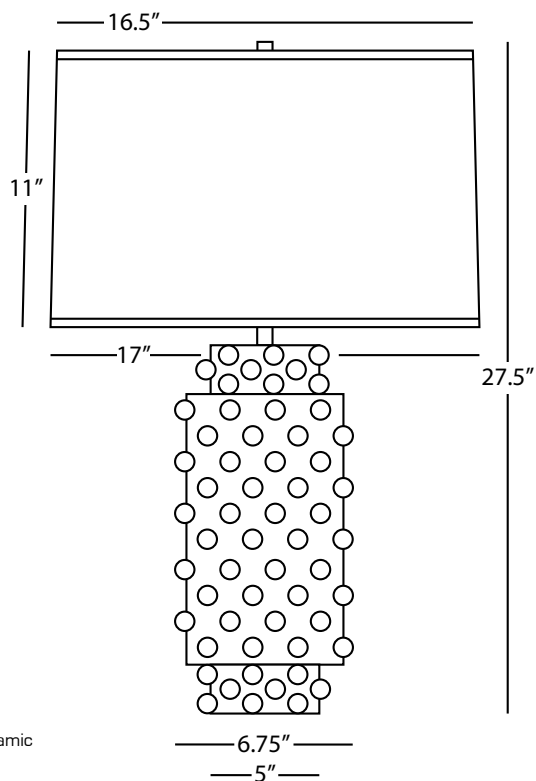

DOLLY

MB800

Table Lamp

1 - 150W Max.
 Bulb Type: A
 Switch: Full Range Dimmer
 Midnight Blue Glazed Textured Ceramic
 Fondine Fabric Shade

See Page 497 for Color Options



G800

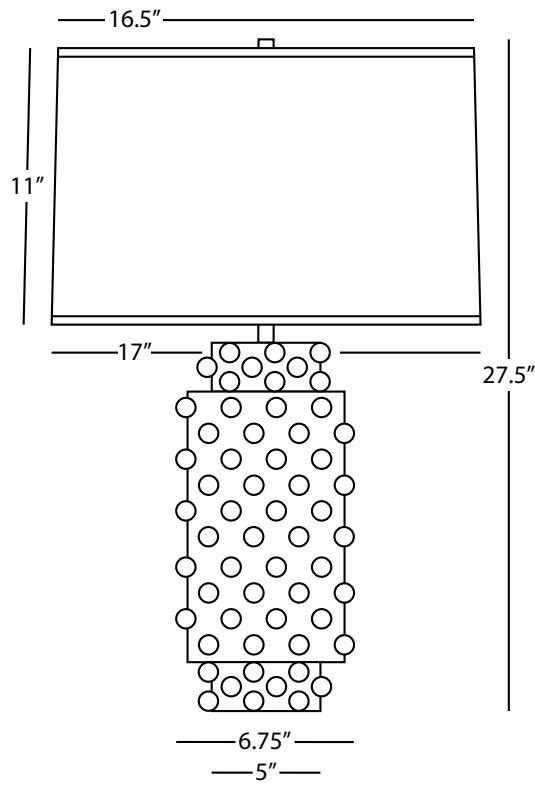

DOLLY

G800
Table Lamp

1 - 150W Max.
Bulb Type: A
Switch: Hi-Lo Dimming
Textured Ceramic w/
Gold Metallic Glaze
Fondine Fabric Shade

FINISH/SHADE OPTIONS:
G800B Gold Metallic Glaze
Black Parchment w/
Gold Foil Lining

Double Gourd



1772X



1617



A770X



CF23X



1673

Double Gourd

DOUBLE GOURD

A770X Accent Lamp

1 - 150W Max.
Bulb Type: A
Switch: 3-Way
Smoky Taupe Glazed Ceramic
Round Lucite Base
Pearl Dupioni Fabric Shade

See Page 498 for
Color/Base/Shade Options

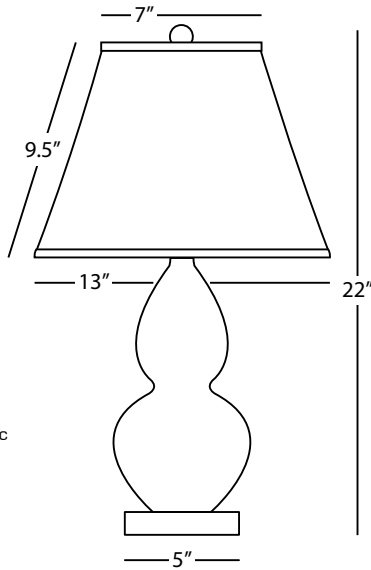

DOUBLE GOURD

1617 Accent Lamp

1 - 150W Max.
Bulb Type: A
Switch: 3-Way
Schiaparelli Pink Glazed Ceramic
Antique Brass Finished Accents
Ivory Stretched Fabric Shade

See Page 498 for
Color/Base/Shade Options

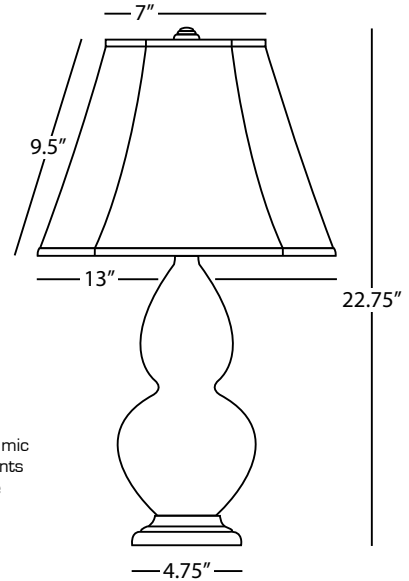

DOUBLE GOURD

1673 Table Lamp

1 - 150W Max.
Bulb Type: A
Switch: 3-Way
Apple Glazed Ceramic
Antique Silver Finished Accents
Ivory Stretched Fabric Shade

See Page 498 for
Color/Base/Shade Options

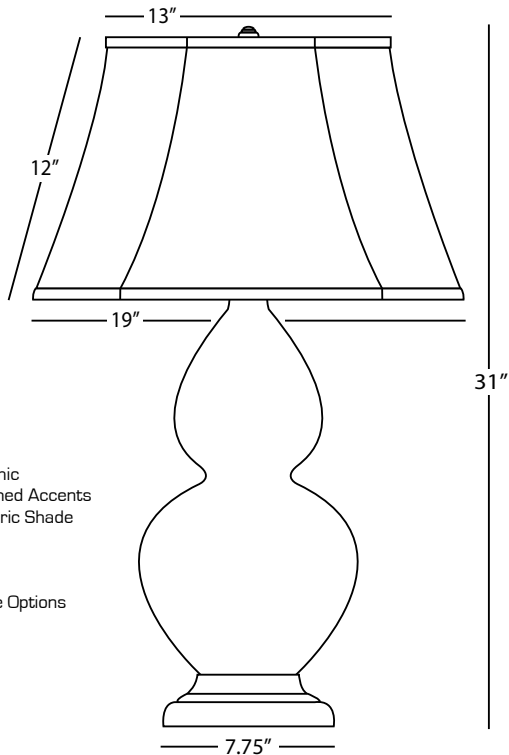

DOUBLE GOURD

CF23X Table Lamp

1 - 150W Max.
Bulb Type: A
Switch: 3-Way
Coffee Glazed Ceramic
Round Lucite Base
Pearl Dupioni Fabric Shade

See Page 498 for
Color/Base/Shade Options

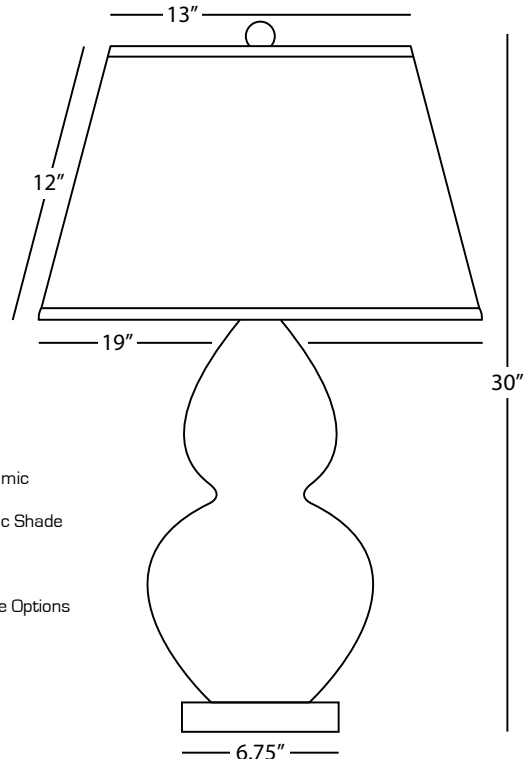

Doughnut



103XBN



102XBZ



104XAS

Doughnut

DOUGHNUT

102G

Duncan Table Lamp

1 - 150W Max.
 Bulb Type: A
 Switch: 3-Way
 Deep Patina Bronze Finish
 Ebony Finished Wood Base
 Rectangular Smoke Gray Fabric Shade

FINISH OPTIONS:

- 100XBN** Natural Brass/Snowflake
- 101XAS** Antique Silver/Snowflake
- 102XBN** Deep Patina Bronze/Snowflake
- 100G** Natural Brass/Smoke Gray
- 101G** Antique Silver/Smoke Gray

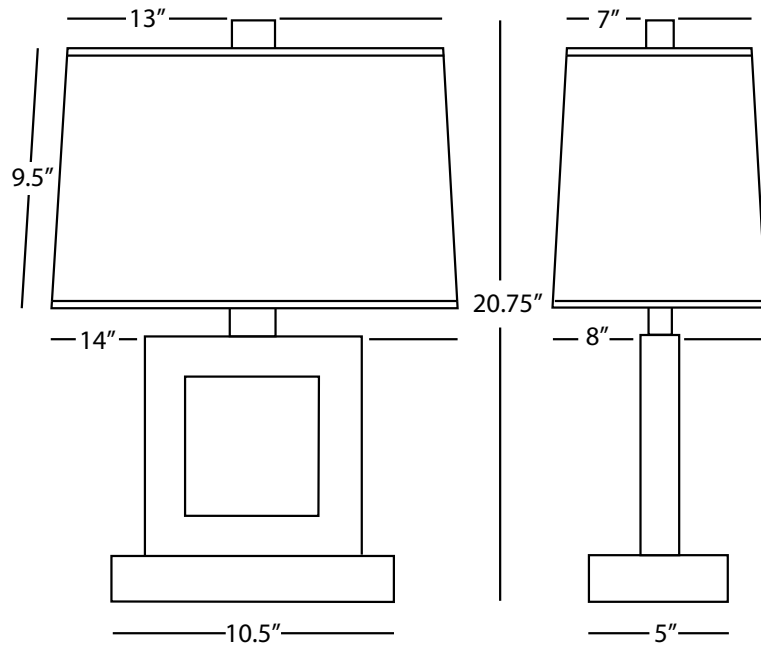

DOUGHNUT

103XBN

Jerry Table Lamp

1 - 150W Max.
 Bulb Type: A
 Switch: 3-Way
 Natural Brass Finish
 Ebony Finished Wood Base
 Rectangular Snowflake Fabric Shade

FINISH OPTIONS:

- 104XAS** Antique Silver/Snowflake
- 105XBZ** Deep Patina Bronze/Snowflake
- 103G** Natural Brass/Smoke Gray
- 104G** Antique Silver/Smoke Gray
- 105G** Deep Patina Bronze/Smoke Gray

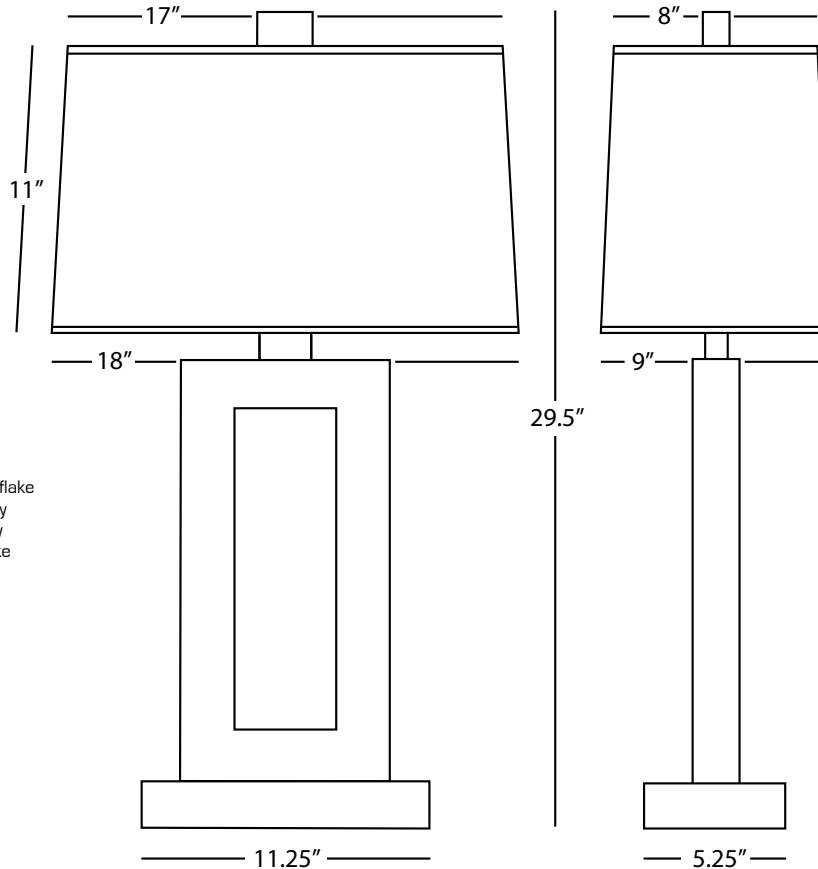

Doughnut



147



Z149

Doughnut

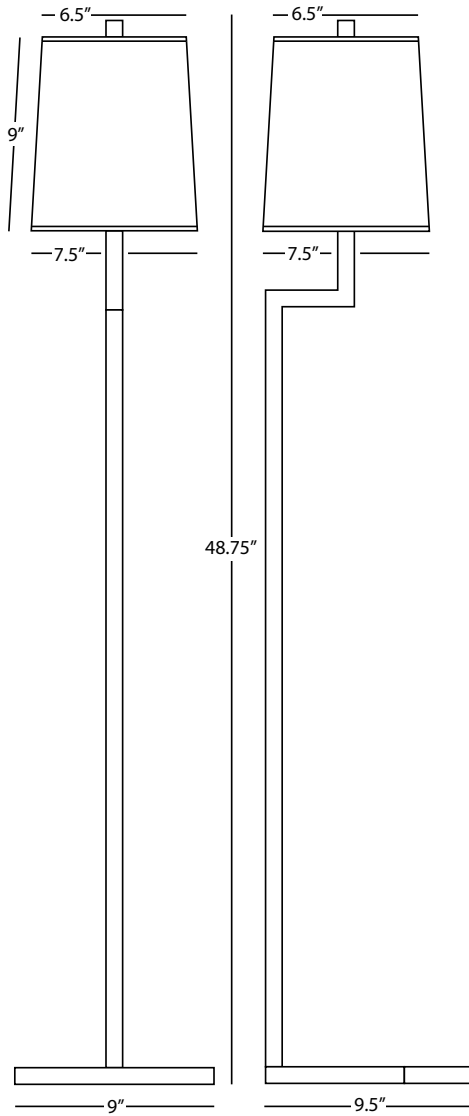

DOUGHNUT

Z149 Mini "C" Floor Lamp

1 - 100W Max.
Bulb Type: A
Switch: Full Range Dimmer
Deep Patina Bronze Finish
Square Snowflake Fabric Shade
w/ Top Diffuser

FINISH OPTIONS:

- 149** Natural Brass
- 149G** Natural Brass/Smoke
Gray Fabric
- S149** Antique Silver
- S149G** Antique Silver/Smoke
Gray Fabric
- Z149G** Deep Patina Bronze/
Smoke Gray Fabric

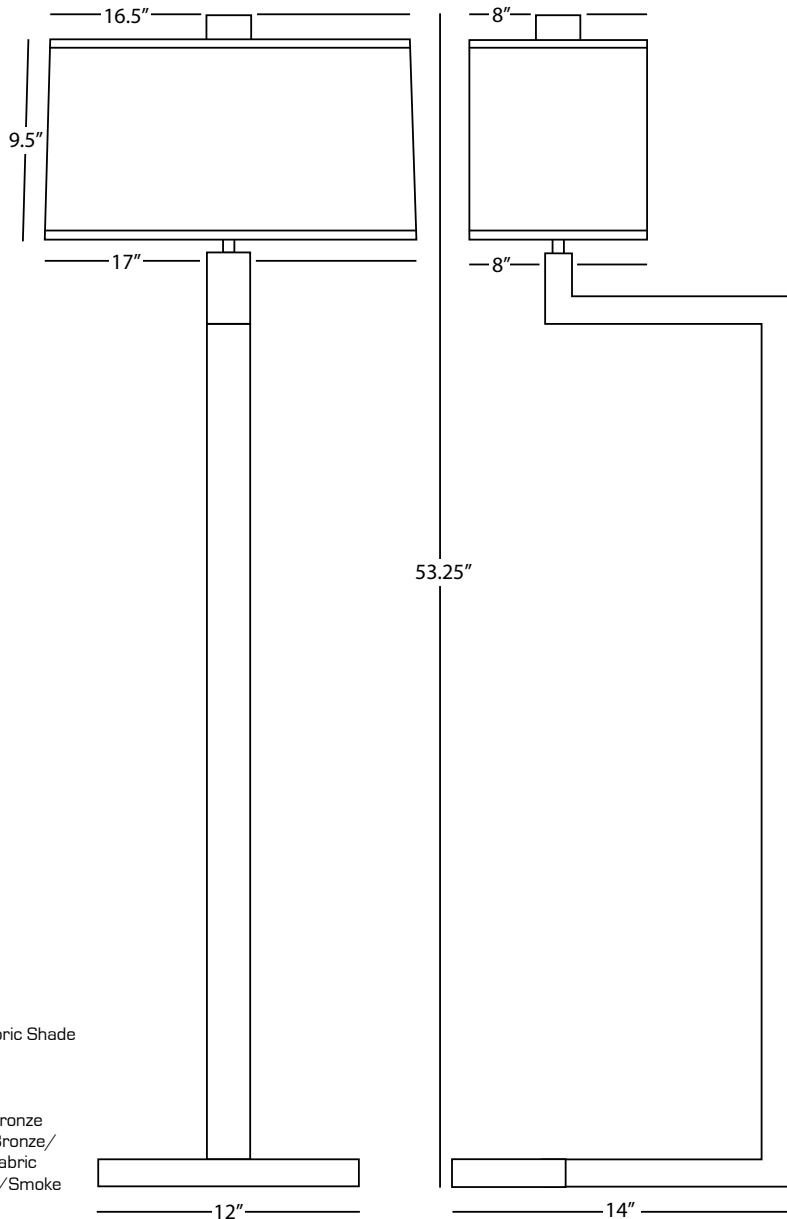

DOUGHNUT

147 "C" Floor Lamp

2 - 100W Max.
Bulb Type: A
Switch: Hi-Lo Dimming
Antique Silver Finish
Rectangular Snowflake Fabric Shade

FINISH OPTION:

- 148** Deep Patina Bronze
- 148G** Deep Patina Bronze/
Smoke Gray Fabric
- 147G** Antique Silver/Smoke
Gray Fabric

Doughnut

139



Z139



S139



106X



107X



108X

Doughnut

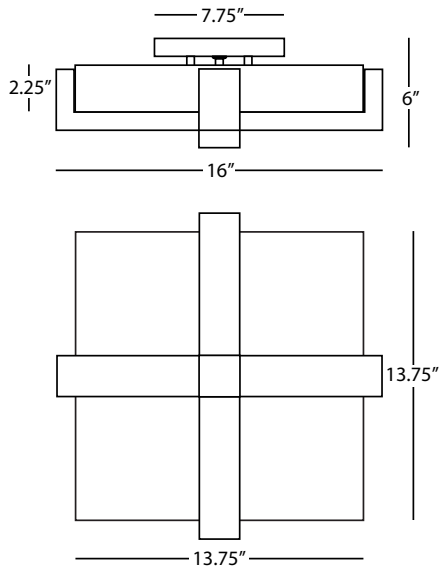

DOUGHNUT

139 Flush Mount

2 - 60W Max.
Bulb Type: T-10 Medium Base
Direct Wire Only
Natural Brass Finish
Marbleized Glass Shade

FINISH OPTIONS:

S139 Antique Silver
Z139 Deep Patina Bronze

DOUGHNUT

106X Floor Lamp

1 - 150W Max.
Bulb Type: A
Switch: 3-Way
Natural Brass Finish
Ebony Finished Wood Base
Rectangular Snowflake Fabric Shade

FINISH OPTIONS:

107X Deep Patina Bronze
108X Antique Silver
107G Deep Patina Bronze/
Smoke Gray Fabric
108G Antique Silver/Smoke
Gray Fabric
106G Natural Brass/Smoke
Gray Fabric

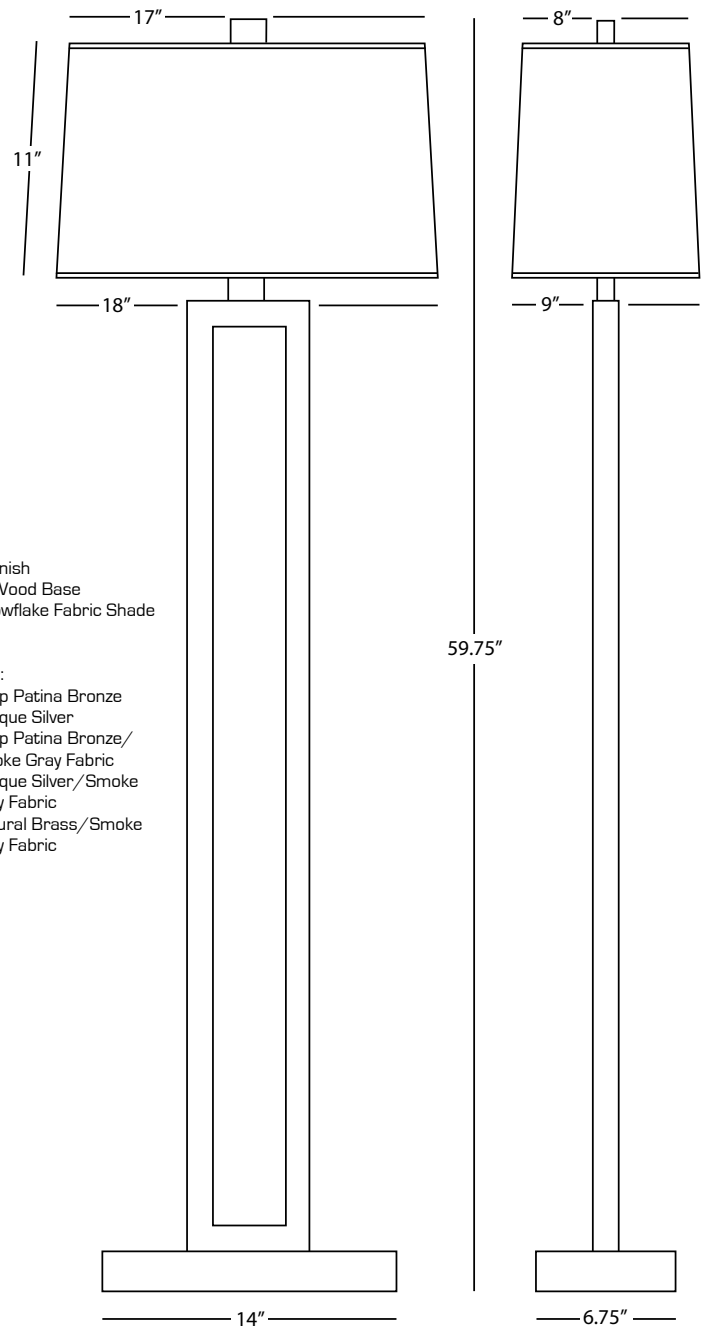



115



S115



Z115

Doughnut

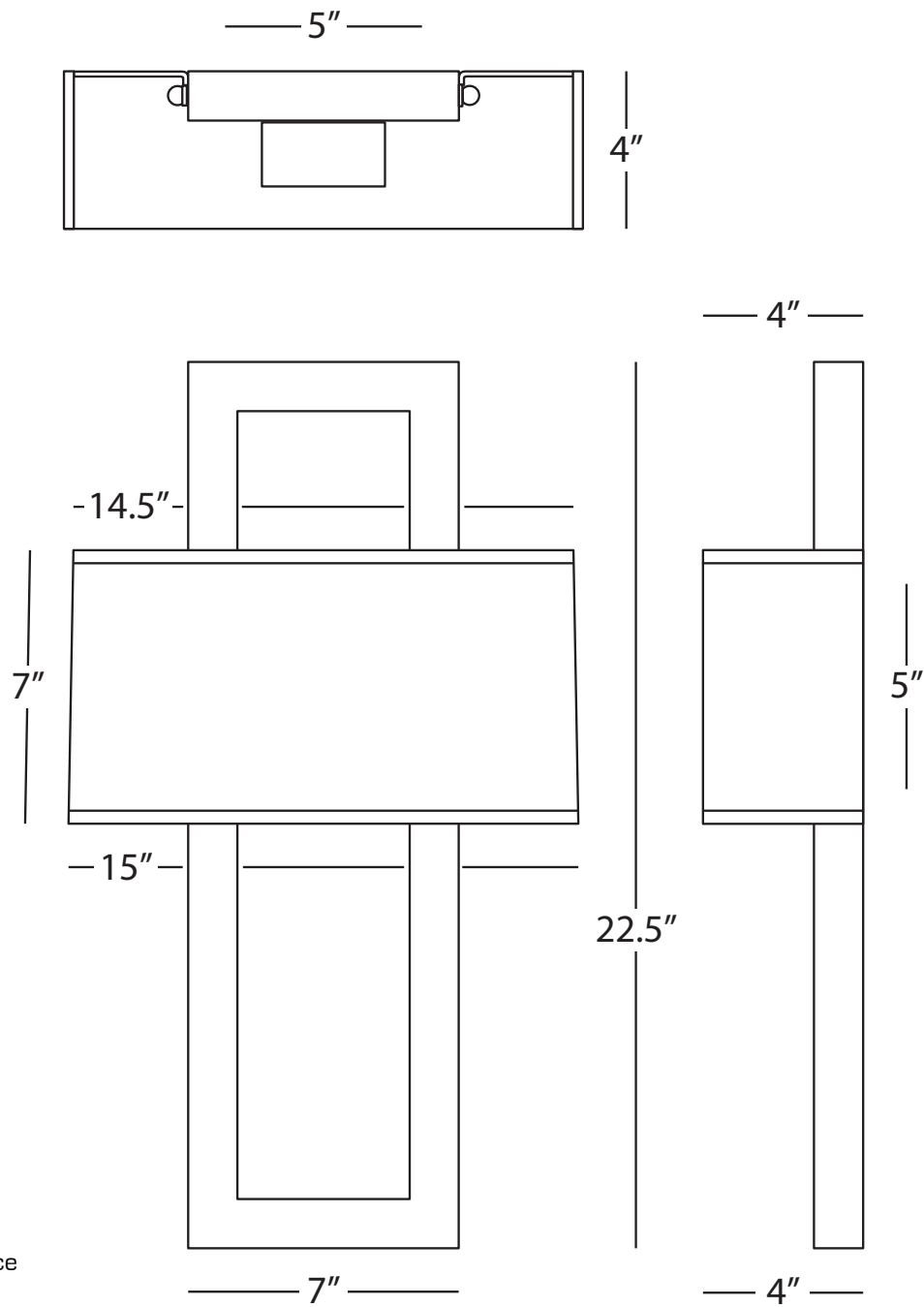

DOUGHNUT

115

Wall Sconce

2 - 25W Max.
 Bulb Type: B, Medium Base
 Direct Wire Only
 Antique Brass Finish
 Rectangular Snowflake Fabric Shade
 ADA Compliant

FINISH OPTIONS:

- S115** Antique Silver
- Z115** Deep Patina Bronze
- 115G** Antique Brass/Smoke Gray Fabric
- S115G** Antique Silver/Smoke Gray Fabric
- Z115G** Deep Patina Bronze/Smoke Gray Fabric

Doughnut



103G



101G



Z115G



107G



149G



147G

Doughnut

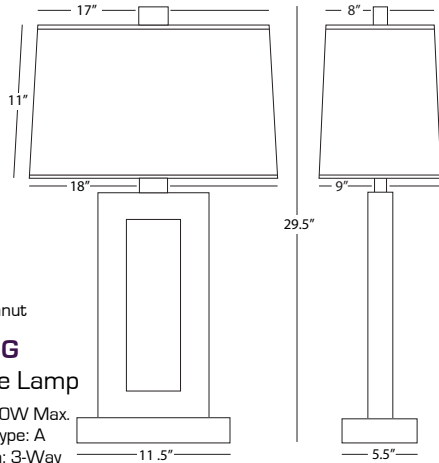

Doughnut
103G
Table Lamp

1 - 150W Max.
Bulb Type: A
Switch: 3-Way
Natural Brass Finish
Ebony Finished Wood Base
Rectangular Smoke Gray Fabric Shade

FINISH OPTIONS:

- 104XAS** Antique Silver / Snowflake
- 105XBZ** Deep Patina Bronze / Snowflake
- 104G** Antique Silver / Smoke Gray
- 105G** Deep Patina Bronze / Smoke Gray

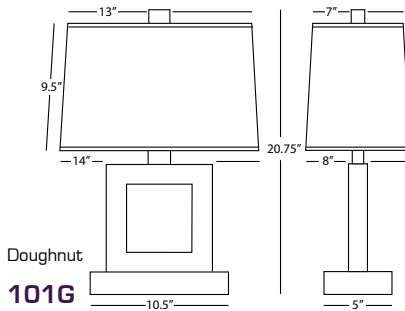

Doughnut
101G
Table Lamp

1 - 150W Max.
Bulb Type: A
Switch: 3-Way
Antique Silver Finish
Ebony Finished Wood Base
Rectangular Smoke Gray Fabric Shade

FINISH OPTIONS:

- 100XBN** Natural Brass / Snowflake
- 101XAS** Antique Silver / Snowflake
- 102XBZ** Deep Patina Bronze / Snowflake
- 100G** Natural Brass / Smoke Gray
- 101G** Antique Silver / Smoke Gray

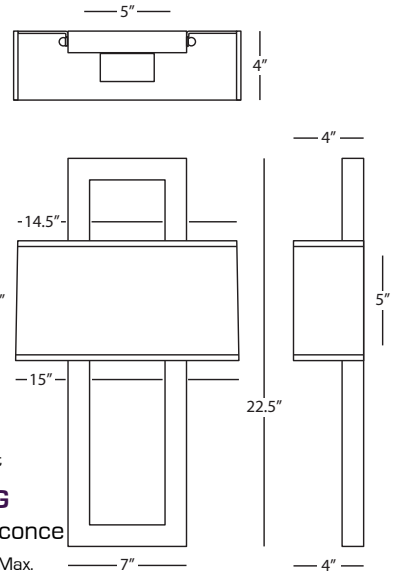

Doughnut
Z115G
Wall Sconce

2 - 25W Max.
Bulb Type: B, Medium Base
Switch: 3-Way
Deep Patina Bronze Finish
Ebony Finished Wood Base
Rectangular Smoke Gray Fabric Shade

FINISH OPTIONS:

- 100XBN** Natural Brass / Snowflake
- 101XAS** Antique Silver / Snowflake
- 102XBZ** Deep Patina Bronze / Snowflake
- 101G** Antique Silver / Smoke Gray
- 100G** Natural Brass / Smoke Gray

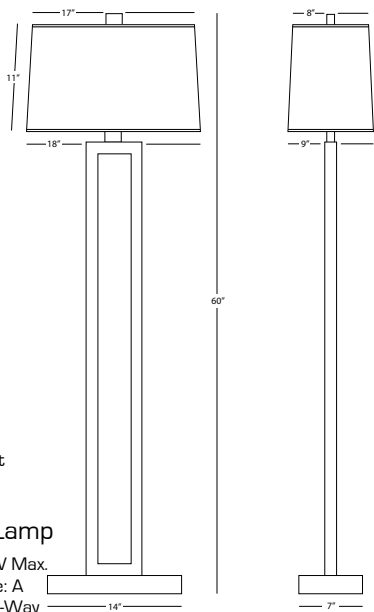

Doughnut
107G
Floor Lamp

1 - 150W Max.
Bulb Type: A
Switch: 3-Way
Deep Patina Bronze Finish
Ebony Finished Wood Base
Rectangular Smoke Gray Fabric Shade

FINISH OPTIONS:

- 106X** Natural Brass / Smoke Gray
- 108X** Antique Silver / Smoke Gray
- 106G** Natural Brass / Smoke Gray
- 108G** Antique Silver / Smoke Gray

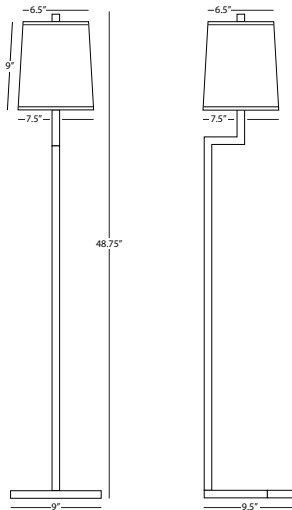

Doughnut
149G
Mini "C" Floor Lamp

1 - 100W Max.
Bulb Type: A
Switch: Full Range Dimmer
Natural Brass Finish
Square Smoke Gray Fabric Shade with Top Diffuser

FINISH OPTIONS:

- Z149G** Deep Patina Bronze / Smoke Gray
- S149G** Antique Silver / Smoke Gray
- 149** Natural Brass / Snowflake
- S149** Antique Silver / Smoke Gray
- Z149** Deep Patina Bronze / Smoke Gray

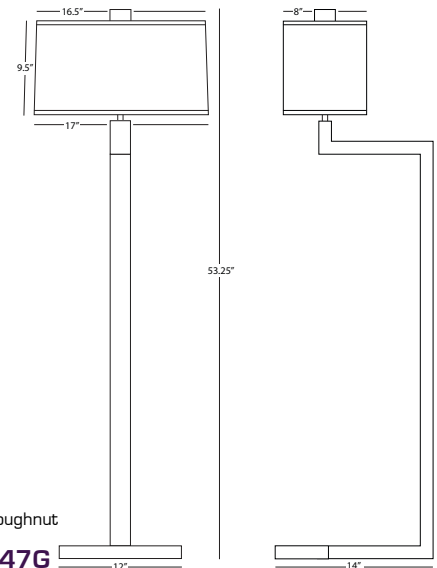

Doughnut
147G
"C" Floor Lamp

2 - 100W Max.
Bulb Type: A
Switch: Hi-Lo Dimming
Antique Silver Finish
Square Smoke Gray Fabric Shade

FINISH OPTIONS:

- 148G** Deep Patina Bronze / Smoke Gray



Z2170



S2181



Z2175



S2184

Echo

ECHO

S2184

Accent Lamp

1 - 60W Max.
 Bulb Type: G16.5 Candelabra
 Switch: On-Off Line Switch
 Stainless Steel Finish
 Fondine Fabric Shade

FINISH OPTION:

Z2174 Deep Patina Bronze

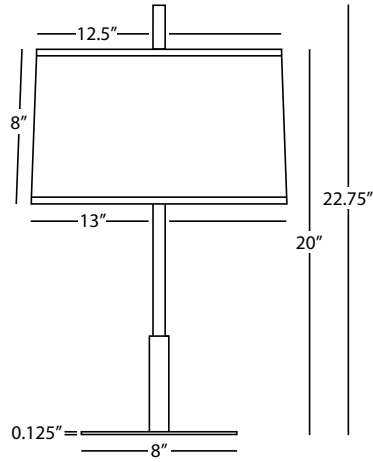

ECHO

Z2175

Buffet Lamp

1 - 60W Max.
 Bulb Type: G16.5 Candelabra
 Switch: On-Off Line Switch
 Deep Patina Bronze Finish
 Fondine Fabric Shade

FINISH OPTION:

S2185 Stainless Steel

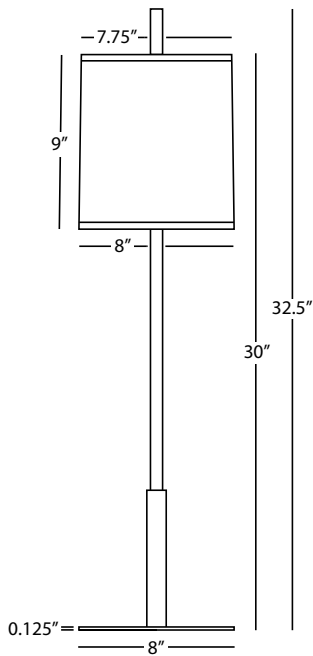

ECHO

Z2170

Table Lamp

1 - 150W Max.
 Bulb Type: A
 Switch: 3-Way
 Deep Patina Bronze Finish
 Fondine Fabric Shade

FINISH OPTION:

S2180 Stainless Steel

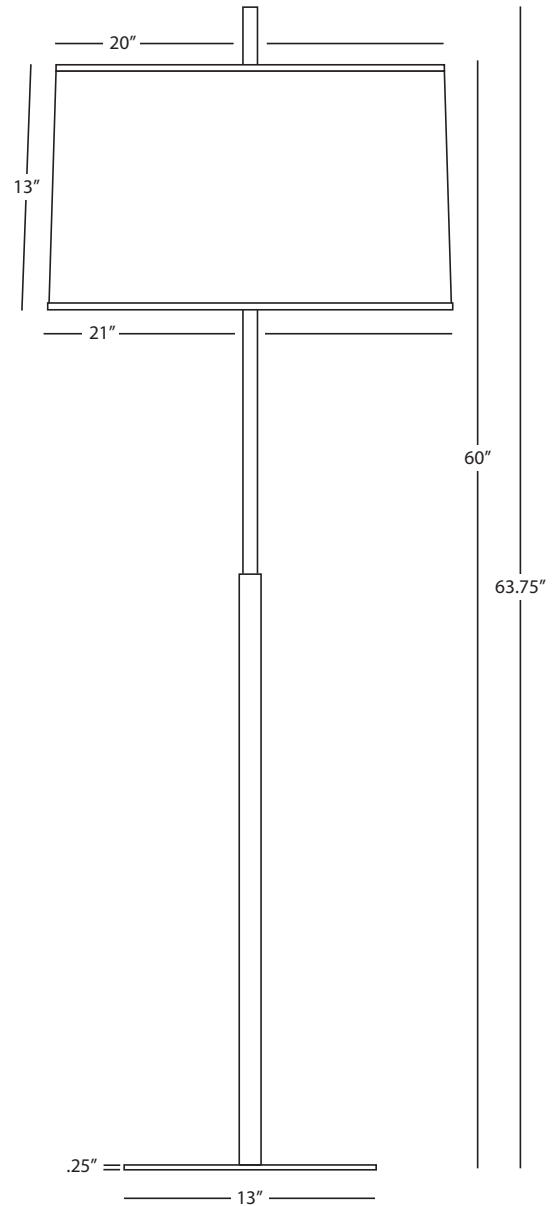
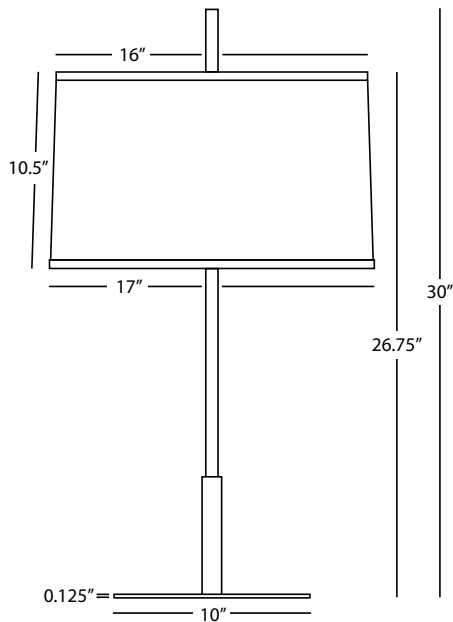

ECHO

S2181

Floor Lamp

1 - 150W Max.
 Bulb Type: A
 Switch: 3-Way
 Stainless Steel Finish
 Fondine Fabric Shade

FINISH OPTION:

Z2171 Deep Patina Bronze



Z2179



Z2176



Z2172



S2188

Echo

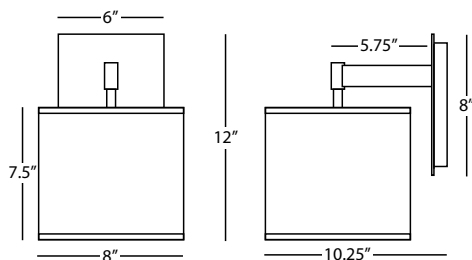

ECHO

Z2172

Wall Sconce

1 - 60W Max.
 Bulb Type: B, Candelabra
 Switch: On-Off Line Switch
 24" Cord Cover/Direct Wire
 Deep Patina Bronze Finish
 Fondine Fabric Shade

FINISH OPTION:
S2182 Stainless Steel

ECHO

Z2179

Pendant

3 - 100W Max.
 Bulb Type: A
 Direct Wire Only
 Deep Patina Bronze Finish
 Fondine Fabric Shade
 19" Dia. Acrylic Diffuser
 Susp. Hardware: 3 pcs. 5/8" x 12" &
 1 pc. 5/8" x 6" Extensions

FINISH OPTION:
S2189 Stainless Steel

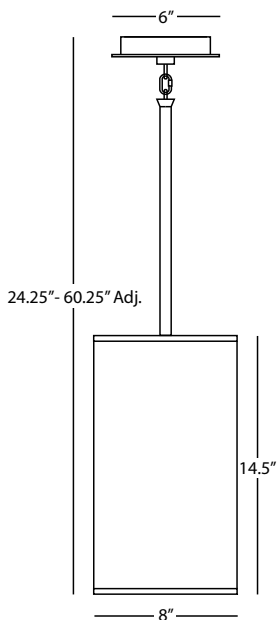
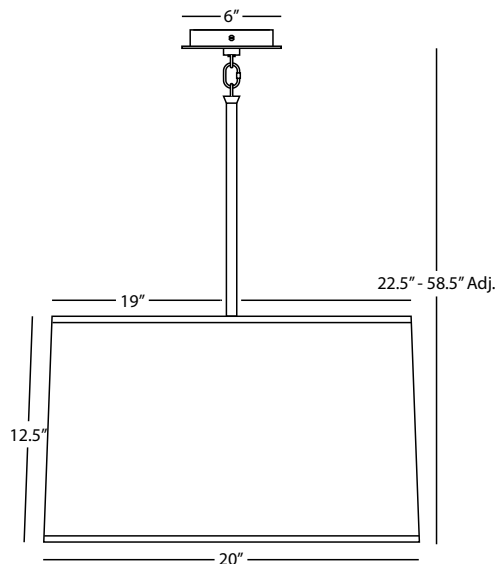

ECHO

Z2186

Narrow Pendant

1 - 60W Max.
 Bulb Type: B, Candelabra
 Direct Wire Only
 Deep Patina Bronze Finish
 Fondine Fabric Shade
 Susp. Hardware: 3 pcs. 5/8" x 12" &
 1 pc. 5/8" x 6" Extensions

ECHO

S2188

6-Light Chandelier

6 - 60W Max.
 Bulb Type: G16.5 Candelabra
 Direct Wire Only
 Stainless Steel Finish
 Fondine Fabric Shades
 Susp. Hardware: 3 pcs. 5/8" x 12"
 & 1 pc. 5/8" x 6" Extensions

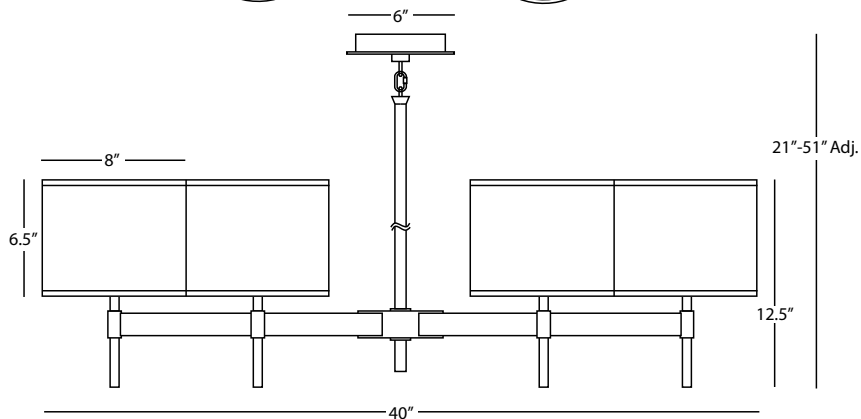
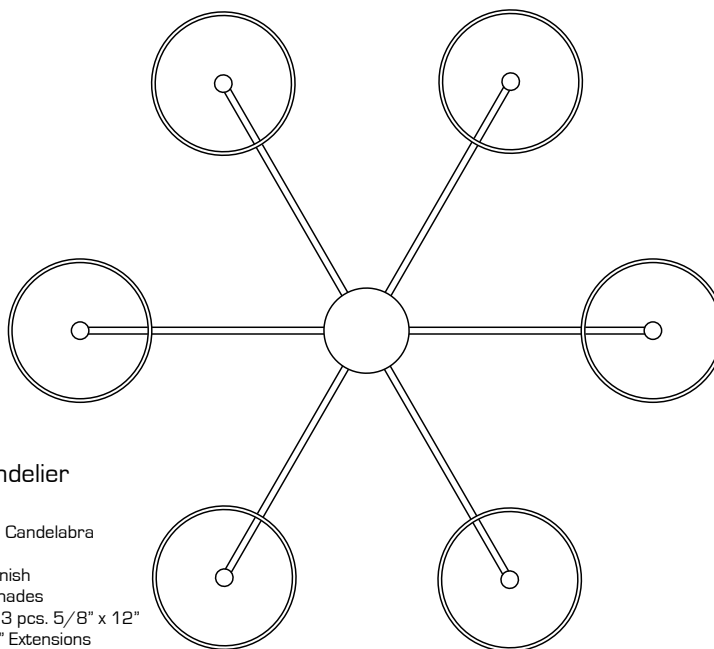



Z2156

Echo

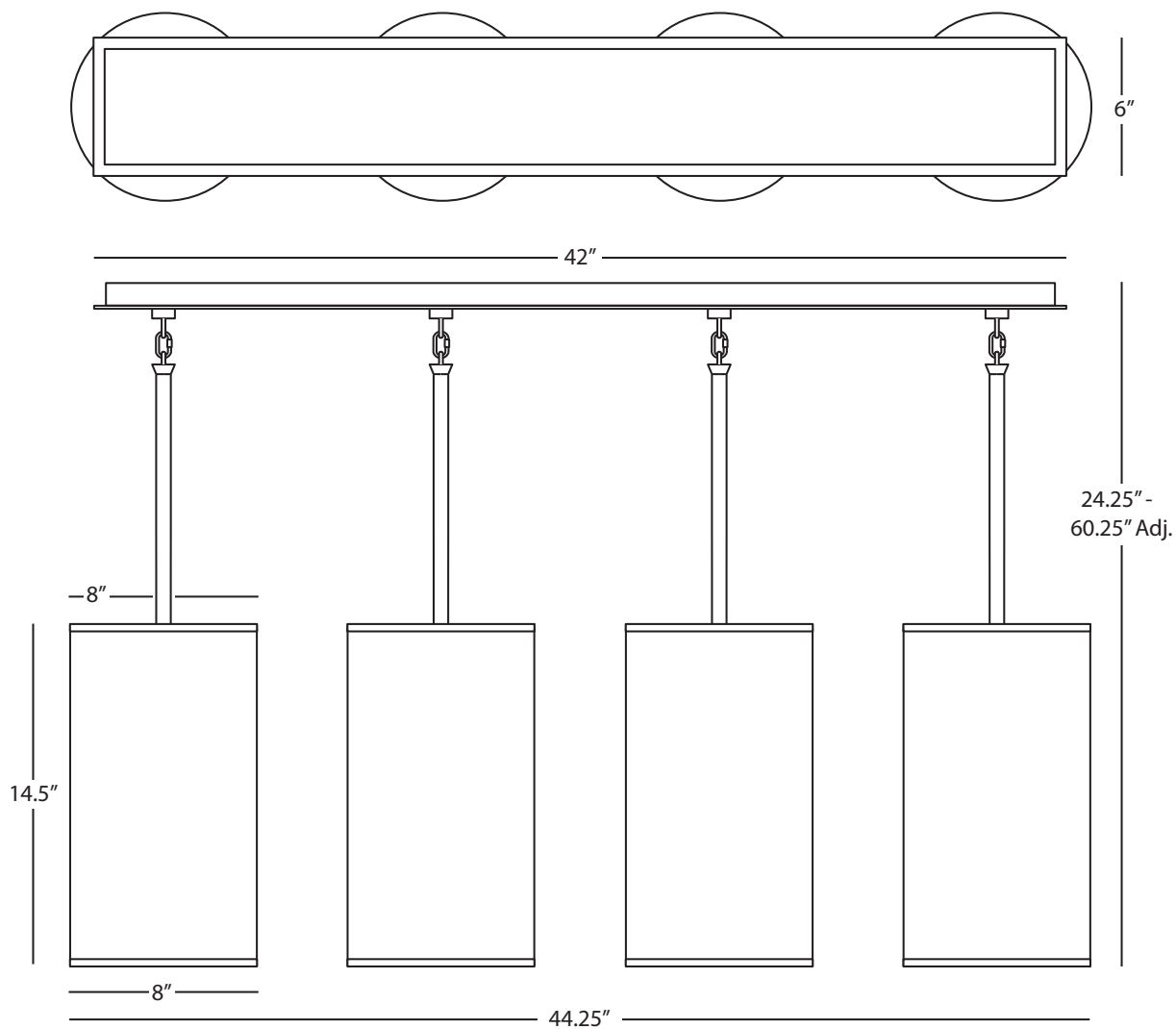

ECHO

Z2156

Linear Chandelier

4 - 60W Max.
Bulb Type: B, Candelabra
Direct Wire
Deep Patina Bronze Finish
Ascot White Fabric Shades
Susp. Hardware: 12 pcs. 5/8" x 12" &
4 pcs. 5/8" x 6" Extensions



W167



B167



W168



K168



B168



K169



B169

ELENA

W167

Small Pendant

1 - 100W Max.
 Bulb Type: A
 Direct Wire
 Pearl Dupioni Fabric Shade
 Susp. Hardware: 12 Ft. White Cord

SHADE OPTIONS:

B167 Bone Dupioni
K167 Mushroom Dupioni

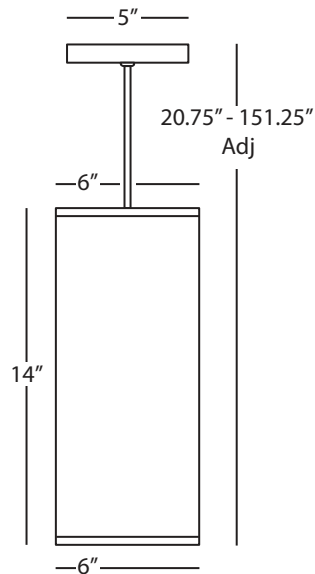

ELENA

K168

Medium Pendant

1 - 100W Max.
 Bulb Type: A
 Direct Wire
 Mushroom Dupioni Fabric Shade w/
 Self-Fabric Bottom Diffuser
 Susp. Hardware: 12 Ft. White Cord

SHADE OPTIONS:

B168 Bone Dupioni
W168 Pearl Dupioni

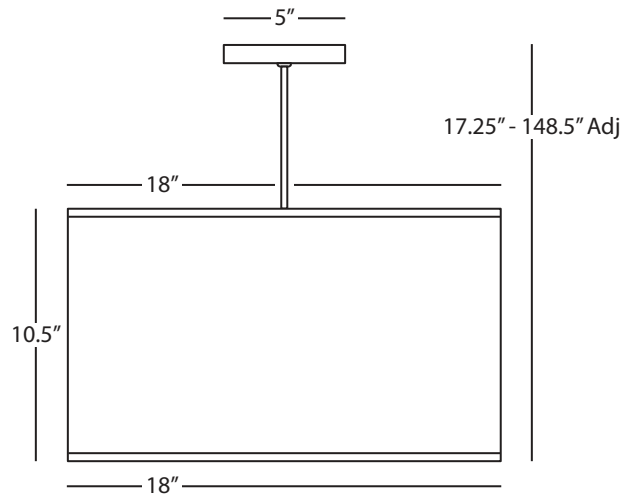

ELENA

B169

Large Pendant

1 - 100W Max.
 Bulb Type: A
 Direct Wire
 Bone Dupioni Fabric Shade w/
 Self-Fabric Bottom Diffuser
 Susp. Hardware: 12 Ft. White Cord

SHADE OPTIONS:

K169 Mushroom Dupioni
W169 Pearl Dupioni

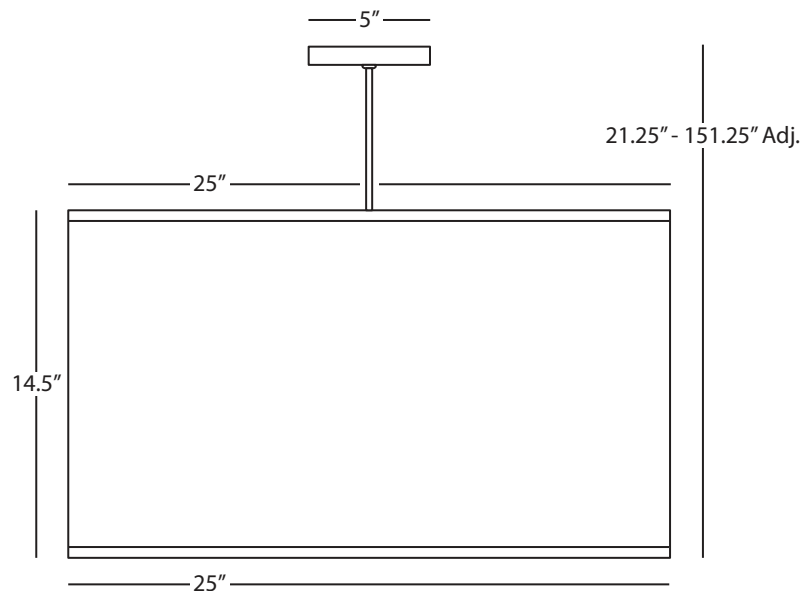

Elena



Elena



[Click photo above to watch Elena video](#)

A modern take on classic candlestick designs, Arthur features tiered tapers and subtle curves that create a timeless and unique look to enhance your space.



B170



K170



W170

Elena

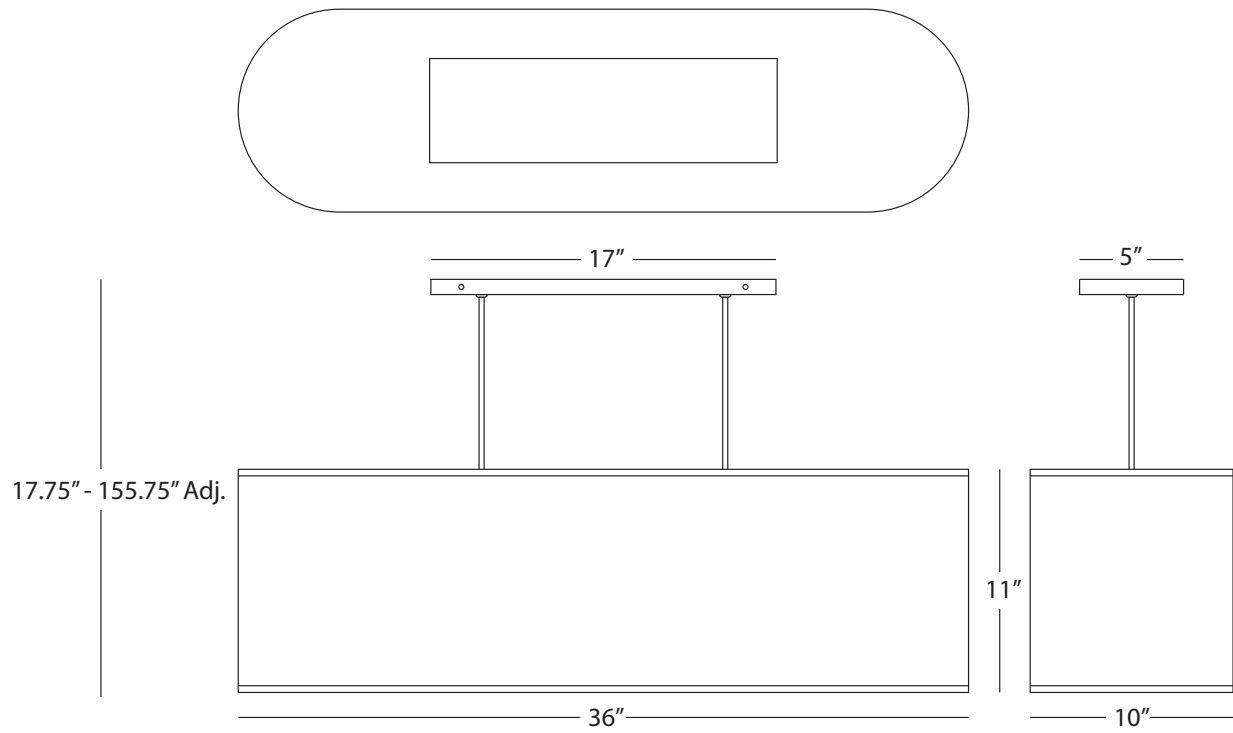

ELENA

B170

Linear Pendant

2 - 100W Max.
Bulb Type: A
Direct Wire Only
Bone Dupioni Fabric w/ Self Fabric Diffuser
Susp. Hardware: 12ft. White Cord

SHADE OPTIONS:

K170 Mushroom Dupioni
W170 Pearl Dupioni



228



S228

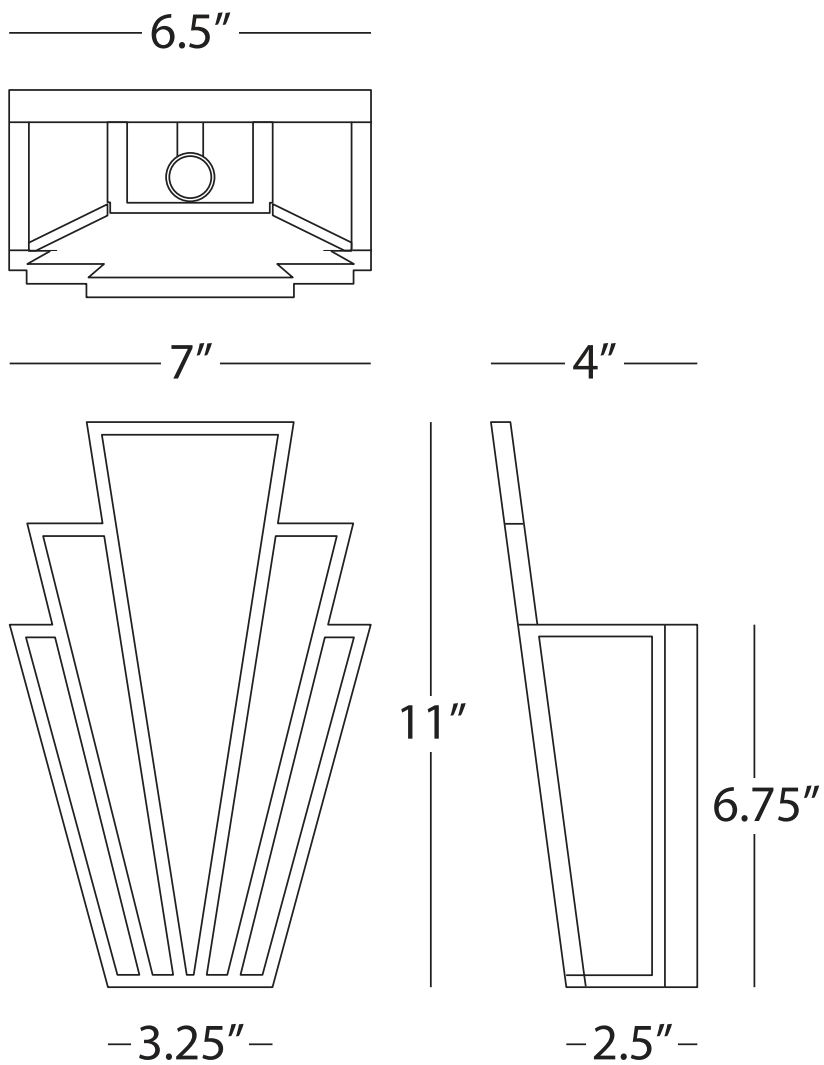

EMPIRE

228

Wall Sconce

1 - 60W Max.
Bulb Type: B, Candelabra
Direct Wire Only
Modern Brass Finish
White Glass Shade Panels
ADA Compliant

FINISH OPTION:

S228 Antique Silver



1210

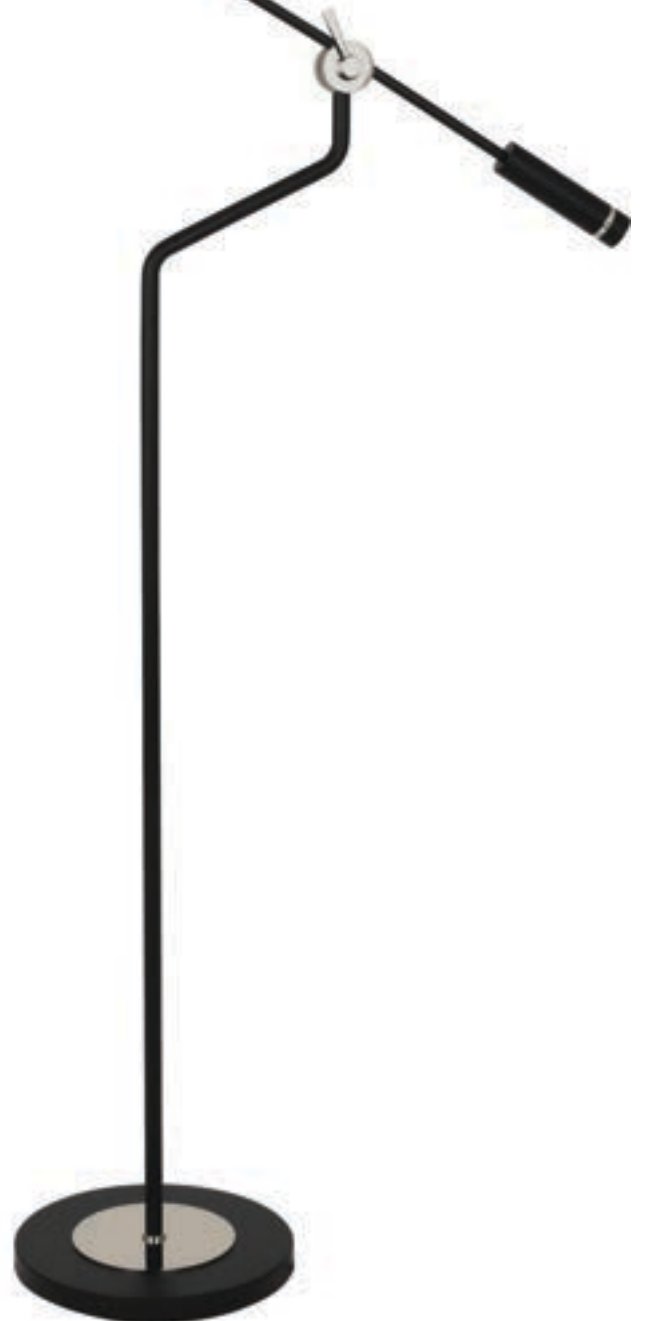

S1211

Ferdinand

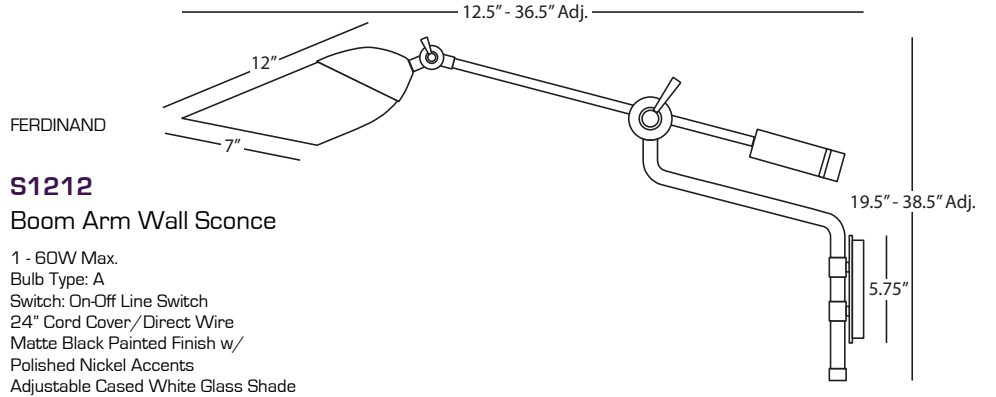

FERDINAND

S1212 Boom Arm Wall Sconce

1 - 60W Max.
Bulb Type: A
Switch: On-Off Line Switch
24" Cord Cover/Direct Wire
Matte Black Painted Finish w/
Polished Nickel Accents
Adjustable Cased White Glass Shade

FINISH OPTION:
1212 Modern Brass Accents

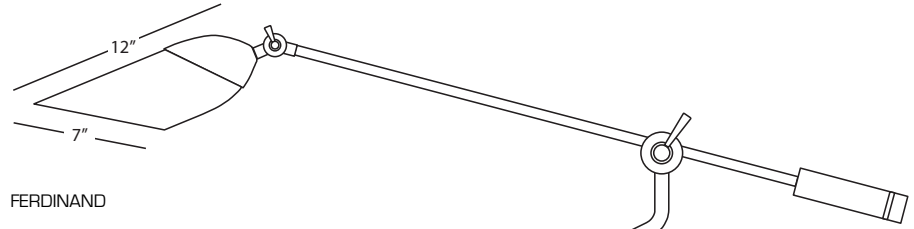

FERDINAND

S1211 Boom Arm Task Floor Lamp

1 - 60W Max.
Bulb Type: A
Switch: Full Range Dimmer Line Switch
Matte Black Painted Finish w/
Polished Nickel Accents
Adjustable, Cased White Glass Shade
Black Fabric Wrapped Cord

FINISH OPTION:
1211 Modern Brass Accents

FERDINAND

1210 Boom Arm Task Table Lamp

1 - 60W Max.
Bulb Type: A
Switch: Full Range Dimmer Line Switch
Matte Black Painted Finish w/
Modern Brass Accents
Adjustable, Cased White Glass Shade
Black Fabric Wrapped Cord

FINISH OPTION:
S1210 Polished Nickel Accents

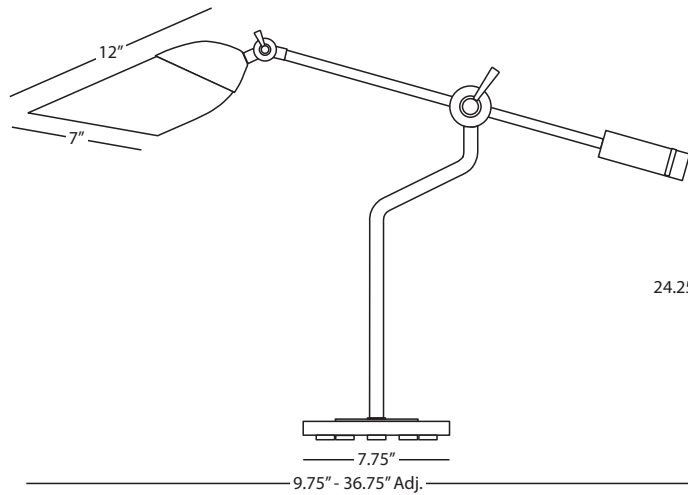

24.25" - 43" Adj.

9.75" - 36.75" Adj.

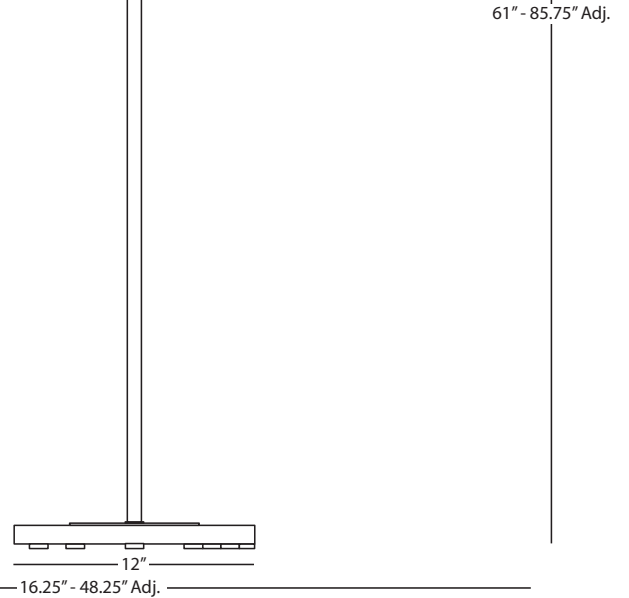

61" - 85.75" Adj.

16.25" - 48.25" Adj.



1518



1418



1526

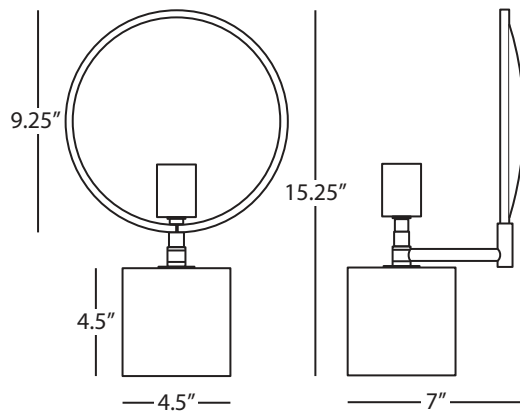

FINEAS

1526 Backlit Accent Lamp

1 - 150W Max.
Bulb Type: A
Switch: Hi-Lo Dimming Line Switch
Alabaster Stone Base
Aged Brass Finish
Clear Seeded Glass Lens

Photographed with Historical Bulb
SOLD SEPARATELY
(HIS01 See Page 225)

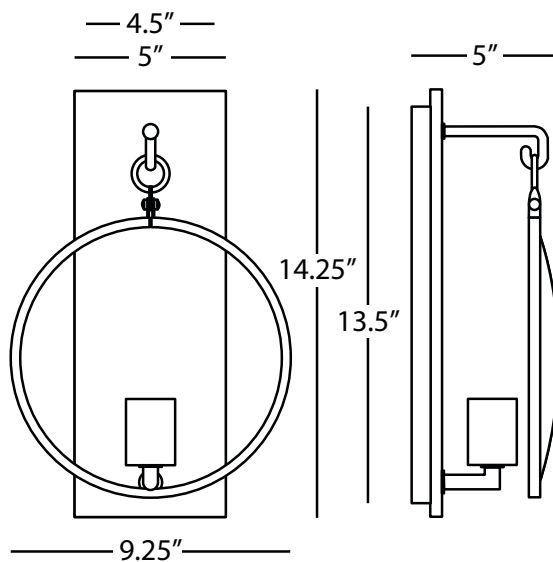

FINEAS

1418 Wall Sconce

1 - 150W Max.
Bulb Type: A
On-Off Line Switch
24" Cord Cover/ Direct Wire
Dark Antique Nickel Finish
Alabaster Stone Back Plate
Clear Seeded Glass Lens

Photographed with Historical Bulb
SOLD SEPARATELY
(HIS01 See Page 225)

FINISH OPTION:
1518 Aged Brass/Alabaster



473B



S472

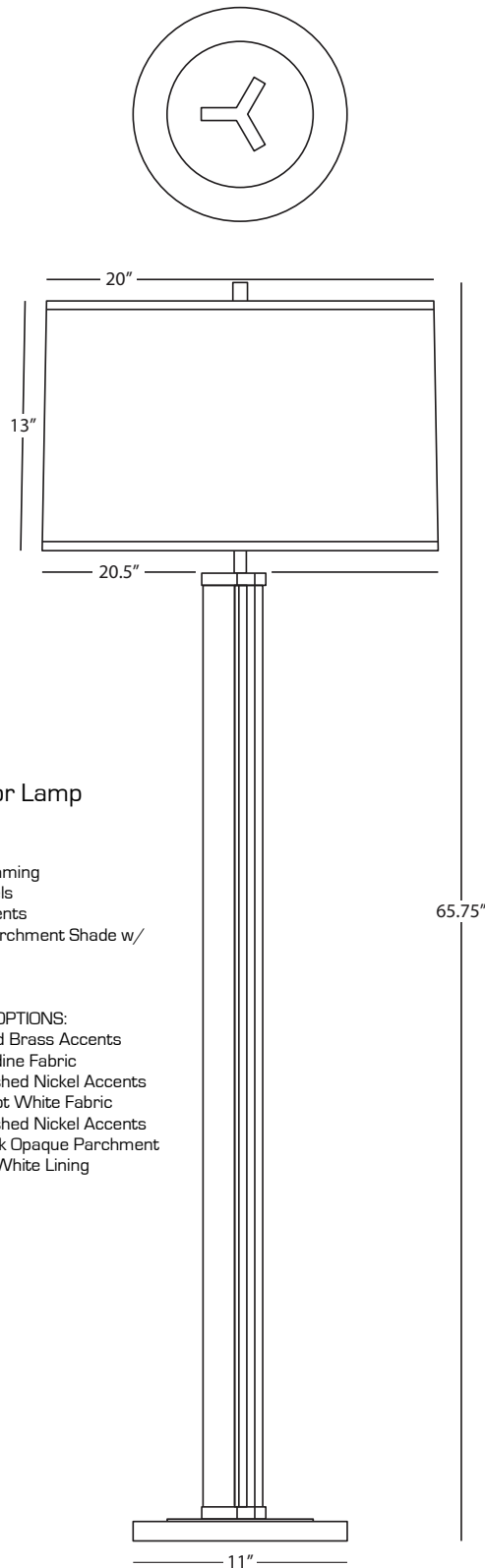

FINEAS

473B
Column Floor Lamp

1 - 150W Max.
Bulb Type: A
Switch: Hi-Lo Dimming
Clear Glass Panels
Aged Brass Accents
Black Opaque Parchment Shade w/
White Lining

FINISH/SHADE OPTIONS:

- 473** Aged Brass Accents
Fondine Fabric
- S473** Polished Nickel Accents
Ascot White Fabric
- S473B** Polished Nickel Accents
Black Opaque Parchment
w/ White Lining

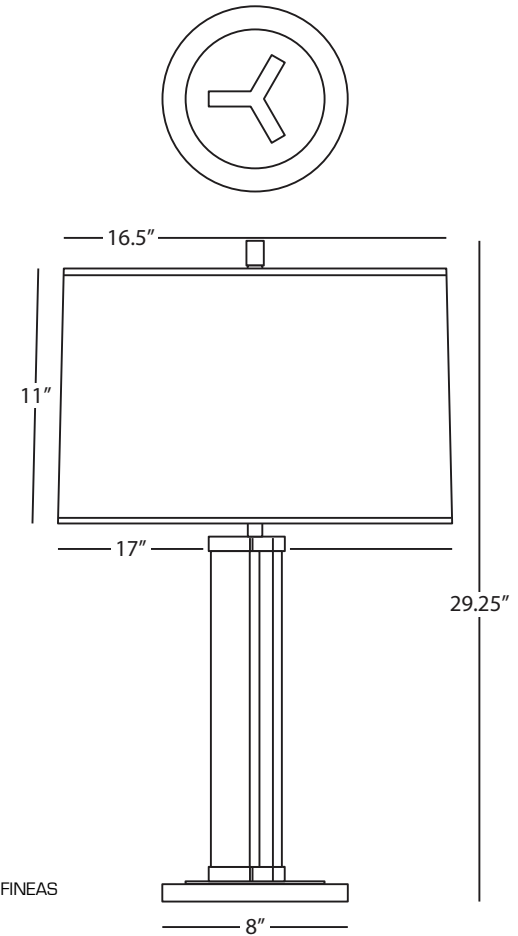

FINEAS

S472
Column Table Lamp

1 - 150W Max.
Bulb Type: A
Switch: Hi-Lo Dimming
Clear Glass Panels
Polished Nickel Accents
Ascot White Fabric Shade

FINISH/SHADE OPTIONS:

- 472** Aged Brass Accents
Fondine Fabric
- 472B** Aged Brass Accents
Black Opaque Parchment
w/ White Lining
- S472B** Polished Nickel Accents
Black Opaque Parchment
w/ White Lining



1041

Fletcher

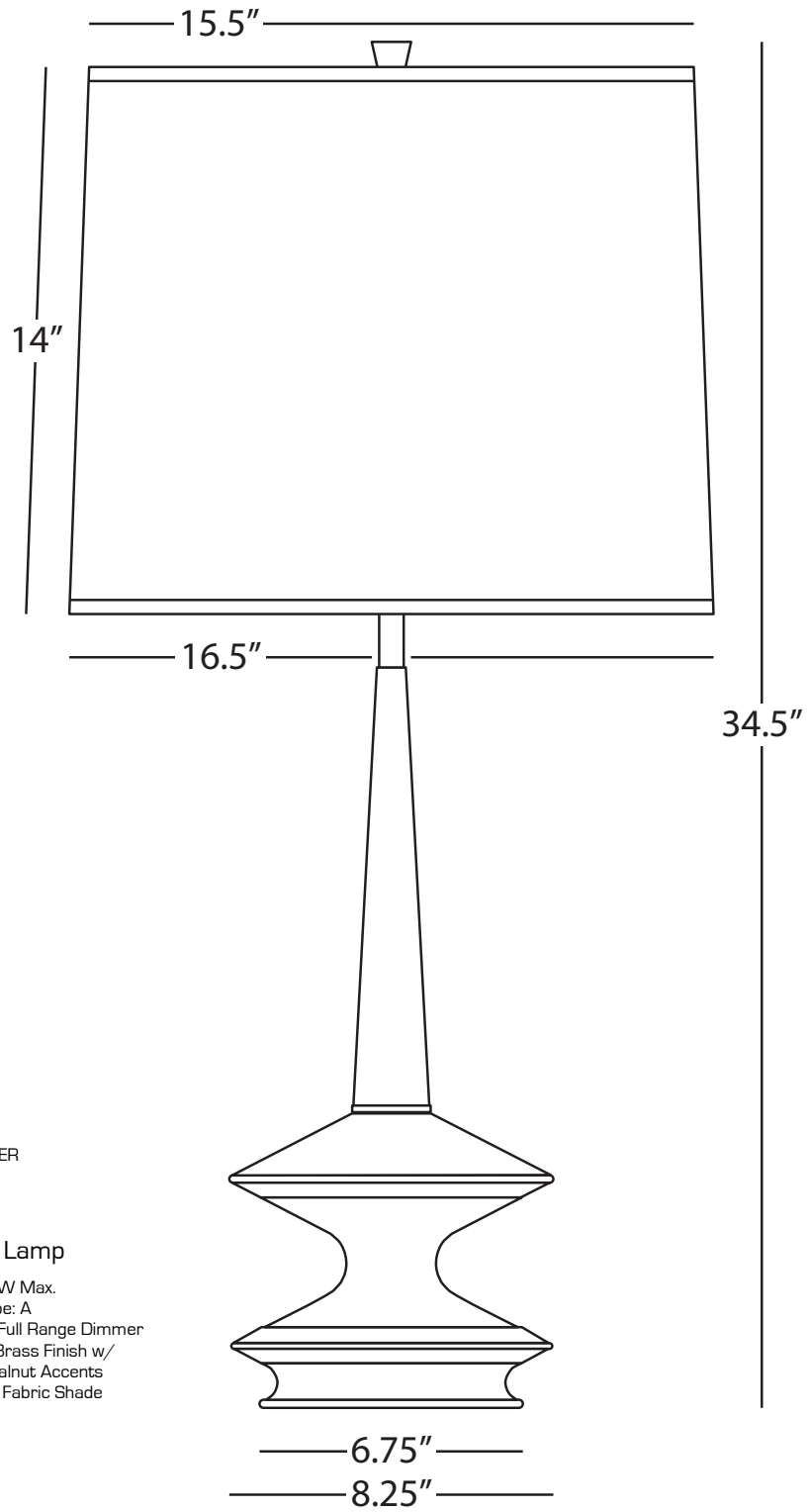

FLETCHER

1041

Table Lamp

1 - 150W Max.
Bulb Type: A
Switch: Full Range Dimmer
Warm Brass Finish w/
Dark Walnut Accents
Fondine Fabric Shade

| Franklin



Franklin

[Click photo above to watch Franklin Table Lamp Video](#)

Inspired by the natural geometry found in turtle shells, the Franklin collection was created to be the perfect accent for your space. Available in a beautiful array of gloss and matte colors, Franklin adds visual interest and provides a pop of color or a stylish contrast.

| Franklin



Franklin

[Click photo above to watch Franklin Accent Lamp Video](#)

Inspired by the natural geometry found in turtle shells, the Franklin collection was created to be the perfect accent for your space. Available in a beautiful array of gloss and matte colors, Franklin adds visual interest and provides a pop of color or a stylish contrast.

Franklin



ST02



MB01



BB02



CM02



PC01



AP02



MCR02



MLY01



MCL02

FRANKLIN

ST02

Accent Lamp

1 - 60W Max.
 Bulb Type: A
 Switch: Full Range Dimmer Line Switch
 Smoky Taupe Glazed Ceramic
 Polished Nickel Accents
 Oyster Linen Shade w/
 Self-Fabric Top Diffuser

See Page 246 for Color Options

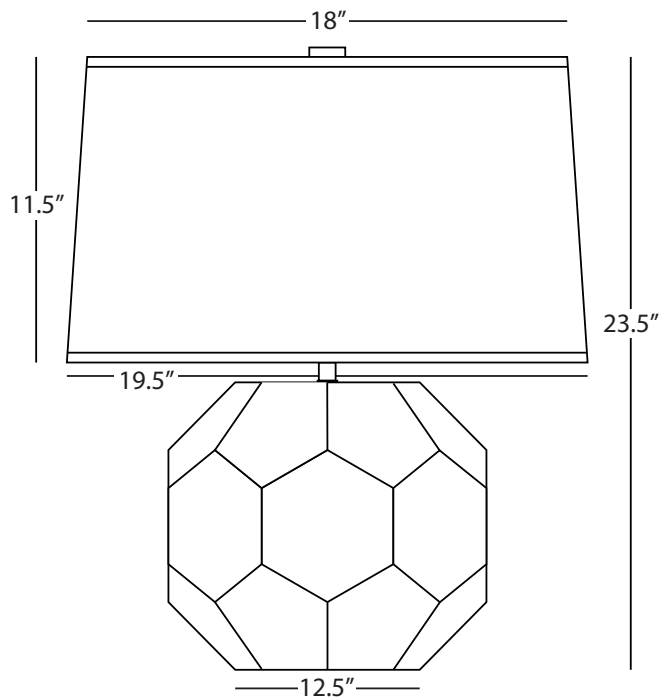
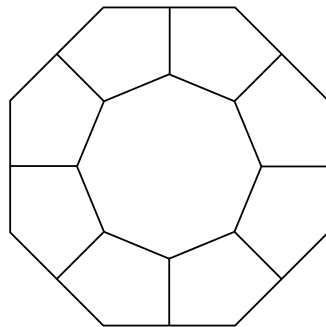
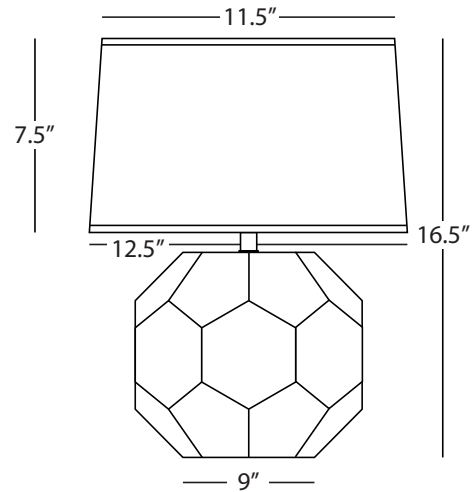
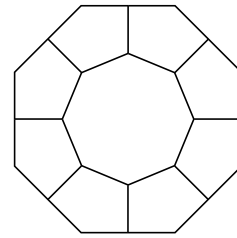

FRANKLIN

MB01

Table Lamp

1 - 150W Max.
 Bulb Type: A
 Switch: Full Range Dimmer
 Midnight Blue Glazed Ceramic
 Polished Nickel Accents
 Oyster Linen Shade w/
 Self-Fabric Top Diffuser

See Page 246 for Color Options



MR981



PM981



CI981



SP981



TE981

Fusion

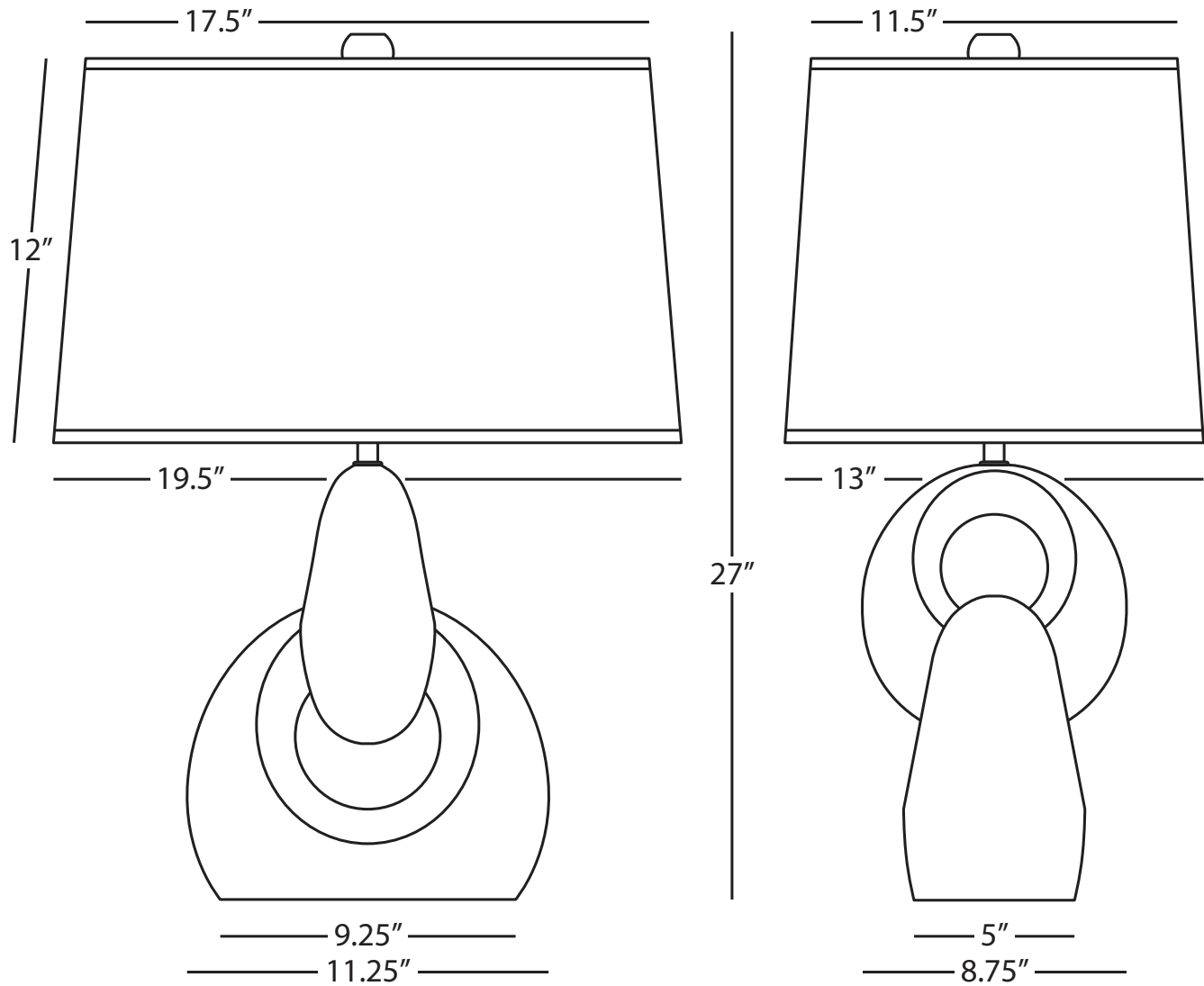

FUSION

C1981

Table Lamp

1 - 150W Max.

Bulb Type: A

Switch: Full Range Dimmer

Citron Glazed Ceramic

Polished Nickel Accents

Oval, Oyster Linen Shade

See Page 500 for Color Options



S373



373

Gemma

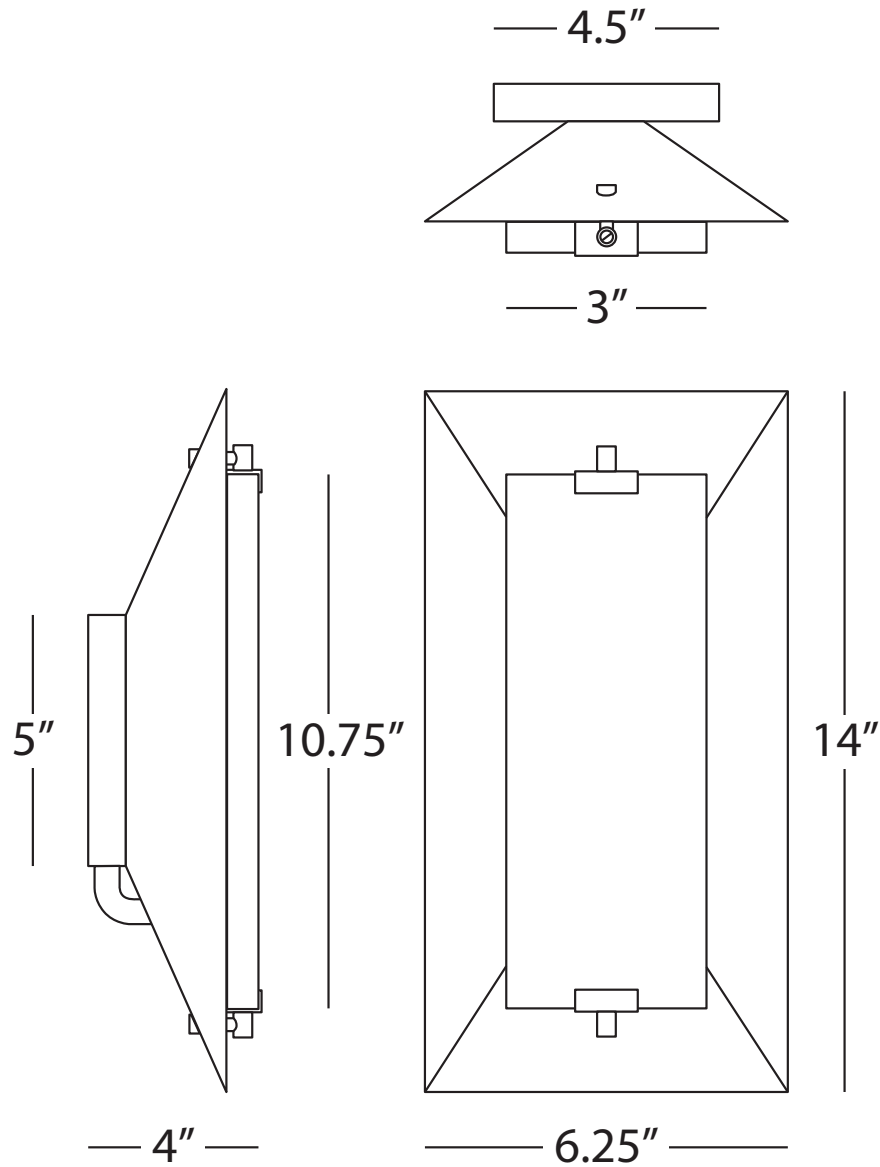

GEMMA

373

Wall Sconce

1 - 60W Max.
Bulb Type: B, Candelabra
Direct Wire Only
Modern Brass Finish w/
Rock Crystal Diffuser
ADA Compliant

FINISH OPTION:

S373 Polished Nickel



W3323

Glass Harriet

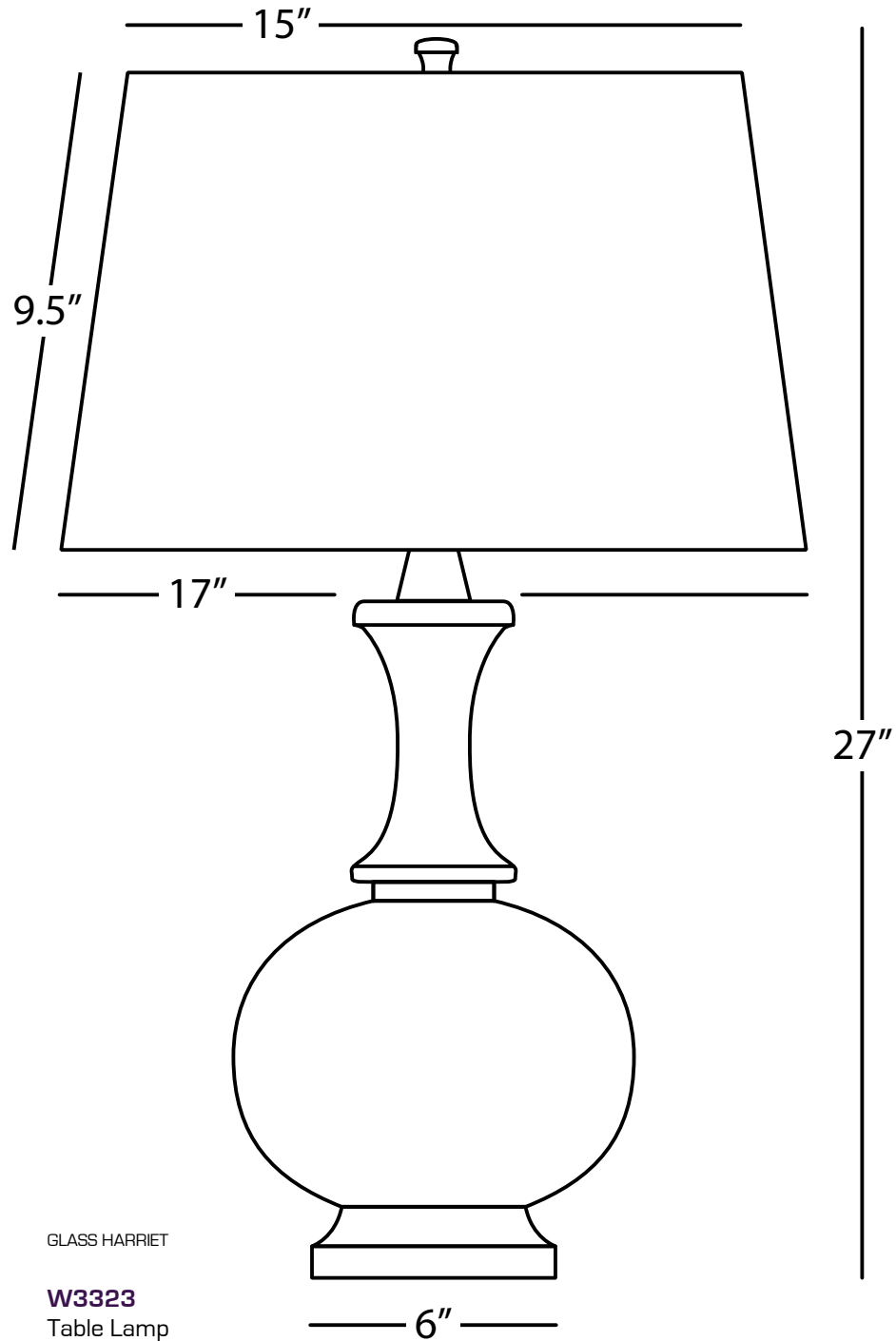

GLASS HARRIET

W3323
Table Lamp

1 - 150W Max.
Bulb Type: A
Switch: Full Range Dimmer
White Glass w/ Polished Nickel Accents
Off-White Cotton Shade w/
Rolled Edge Hem



Z1440



1440

Gloria

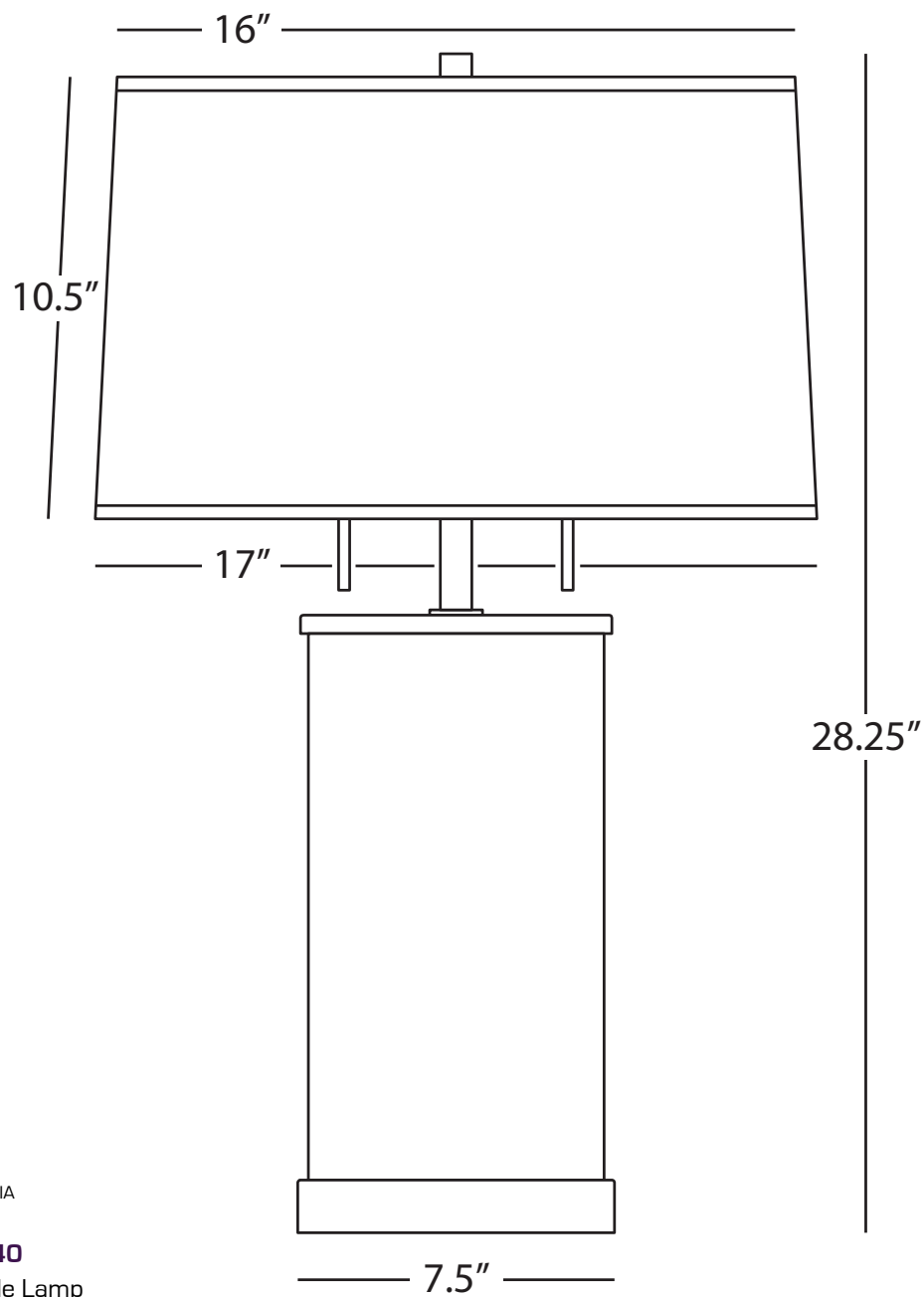

GLORIA

1440
Table Lamp

2 - 150W Max.
Bulb Type: A
Switch: Hi-Lo Pull Chains
Wavy Glass Body w/
Modern Brass Accents
Oyster Linen Shade

FINISH OPTION:
Z1440 Deep Patina Bronze



418



415



S415B

Goliath

GOLIATH

418

Wall Sconce

1 - 60W Max.
 Bulb Type: T, Medium Base
 Switch: On-Off Line Switch
 24" Cord Cover / Direct Wire
 Antiqued Modern Brass Finish
 White Rock Crystal Accent
 ADA Compliant

Photographed with Historical Bulb
 SOLD SEPARATELY
 (HIS01 See Page 225)

FINISH OPTION:

S418 Antiqued Polished Nickel

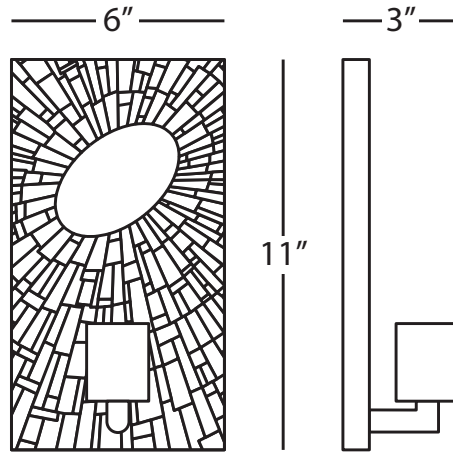

GOLIATH

415

Table Lamp

1 - 100W Max.
 Bulb Type: A
 Switch: Full Range Dimmer
 Antiqued Modern Brass Finish
 White Rock Crystal Accent
 Rectangular Pearl Dupioni Silk Shade

FINISH/SHADE OPTIONS:

415B Antiqued Modern Brass/Black Opaque
 Parchment Shade w/ Matte Gold Lining
S415 Antiqued Polished Nickel/Pearl Dupioni Silk Shade
S415B Antiqued Polished Nickel/Black Opaque
 Parchment Shade w/ Matte Silver Lining

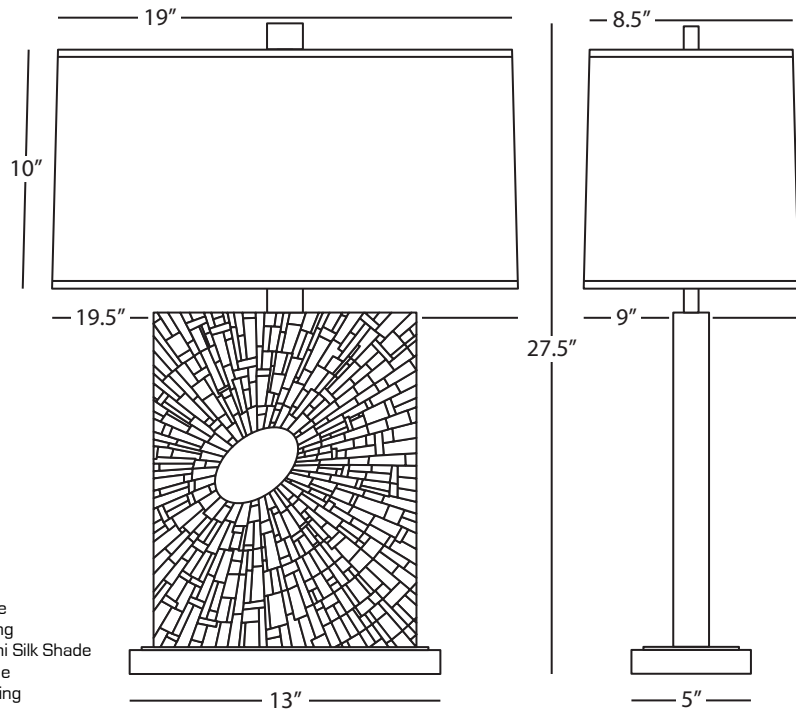

Grace



Grace

[Click photo above to watch Grace Chandelier Video](#)

The Grace collection features elegant bends and eye catching curves. Refined and beautifully balanced, this collection is perfect for transitional or contemporary spaces.



Z467



467



S467

Grace

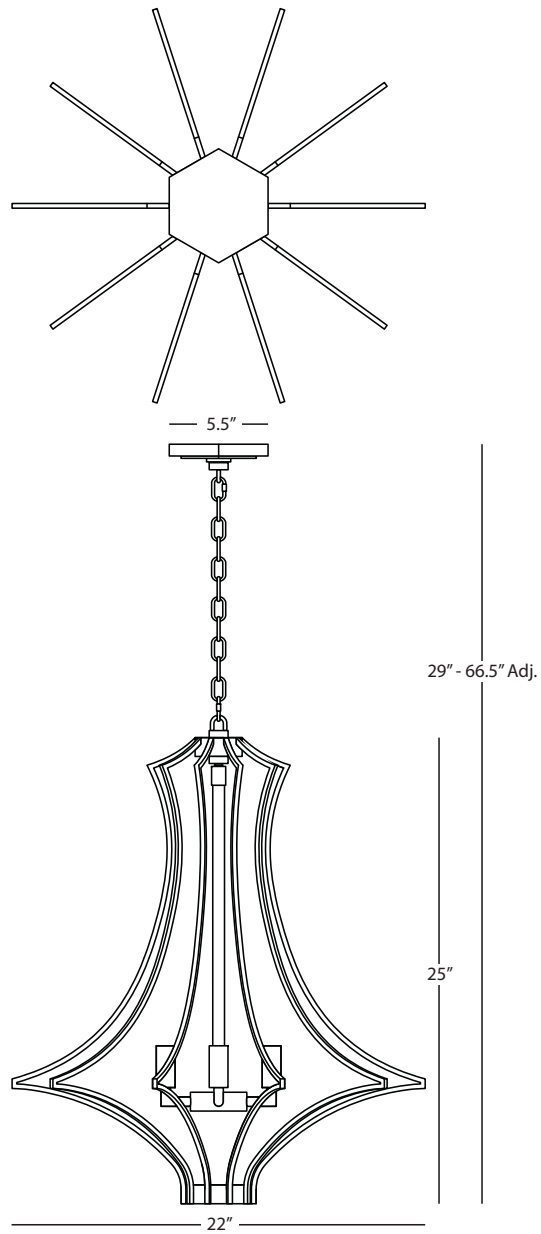

Grace

Z467 Chandelier

4 - 60W Max.
Bulb Type: B, Candelabra
Direct Wire
Deep Patina Bronze
Susp. Hardware: 3 Ft. Chain

FINISH OPTIONS:

467 Modern Brass
S467 Polished Nickel

| Grace



Grace

[Click photo above to watch Grace Single Wall Sconce Video](#)

The Grace collection features elegant bends and eye catching curves. Refined and beautifully balanced, this collection is perfect for transitional or contemporary spaces.

| Grace



| Grace

[Click photo above to watch Grace Double Wall Sconce Video](#)

The Grace collection features elegant bends and eye catching curves. Refined and beautifully balanced, this collection is perfect for transitional or contemporary spaces.

| Grace



| Grace

[Click photo above to watch Grace Triple Wall Sconce Video](#)

The Grace collection features elegant bends and eye catching curves. Refined and beautifully balanced, this collection is perfect for transitional or contemporary spaces.



Z485



484



S486

Grace

Grace

Z485 Double Wall Sconce

2 - 60W Max.
Bulb Type: A
Switch: On-Off Line Switch
24" Cord Cover/Direct Wire
Deep Patina Bronze Finish
Clear Glass Shades

FINISH OPTIONS:

485 Modern Brass
S485 Polished Nickel

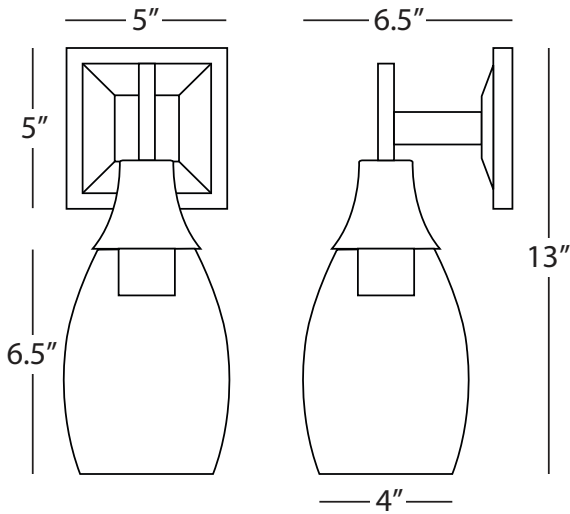
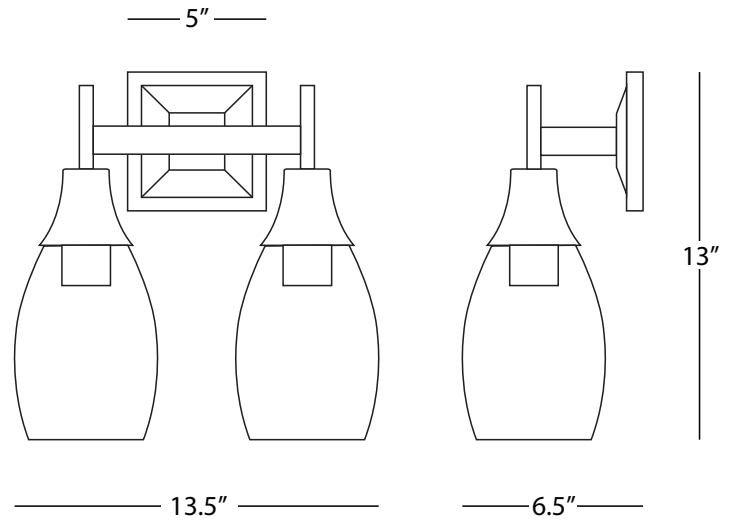

Grace

484 Single Wall Sconce

1 - 60W Max.
Bulb Type: A
Switch: On-Off Line Switch
24" Cord Cover/Direct Wire
Modern Brass Finish
Clear Glass Shade

FINISH OPTIONS:

S484 Polished Nickel
Z484 Deep Patina Bronze

Grace

S486 Triple Wall Sconce

3 - 60W Max.
Bulb Type: A
Switch: On-Off Line Switch
24" Cord Cover/Direct Wire
Polished Nickel Finish
Clear Glass Shades

FINISH OPTIONS:

486 Modern Brass
Z486 Deep Patina Bronze

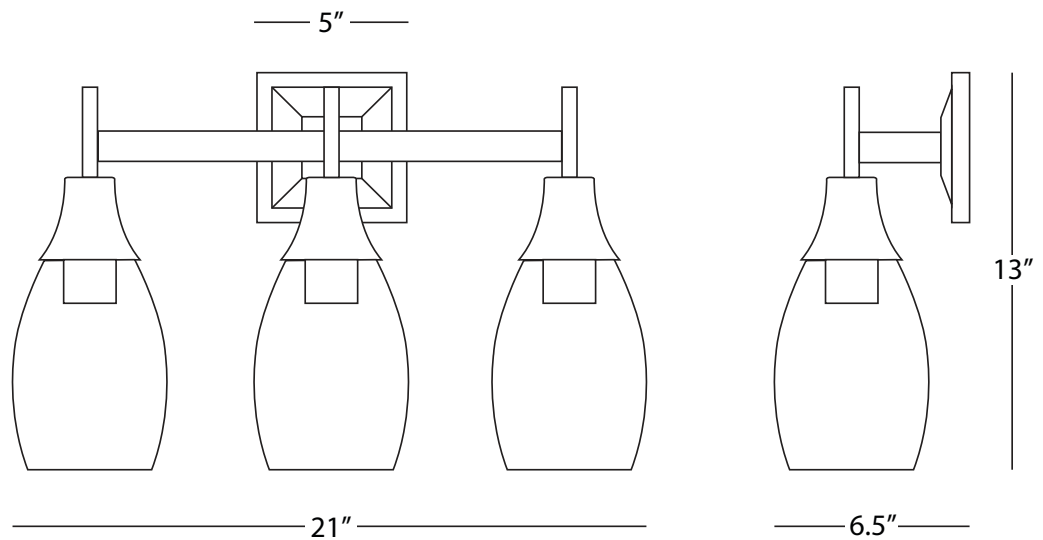

| Grace



Grace

[Click photo above to watch Grace Table Lamp Video](#)

The Grace collection features elegant bends and eye catching curves. Refined and beautifully balanced, this collection is perfect for transitional or contemporary spaces.

Grace



Grace

[Click photo above to watch Grace Floor Lamp Video](#)

The Grace collection features elegant bends and eye catching curves. Refined and beautifully balanced, this collection is perfect for transitional or contemporary spaces.



S466



465

Grace

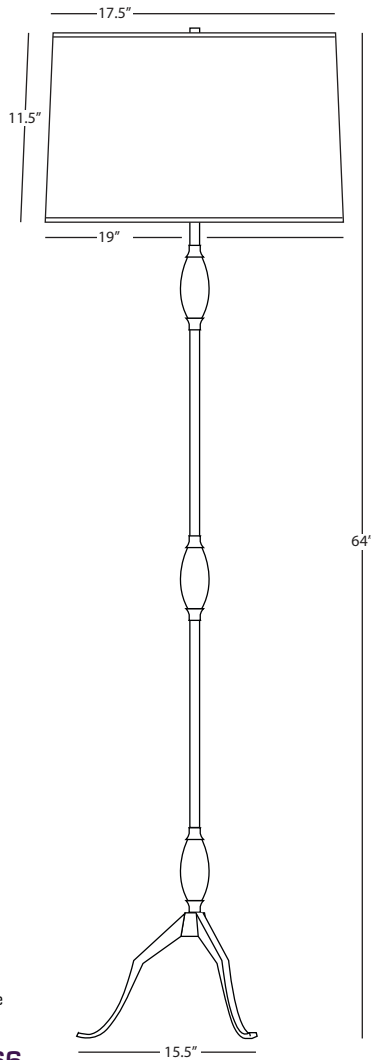
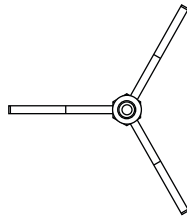

Grace

S466

Floor Lamp

1 - 150W Max.
Bulb Type: A
Switch: Full Range Dimmer
Polished Nickel Finish
Oyster Linen Shade

FINISH OPTIONS:

466 Modern Brass
Z466 Deep Patina Bronze

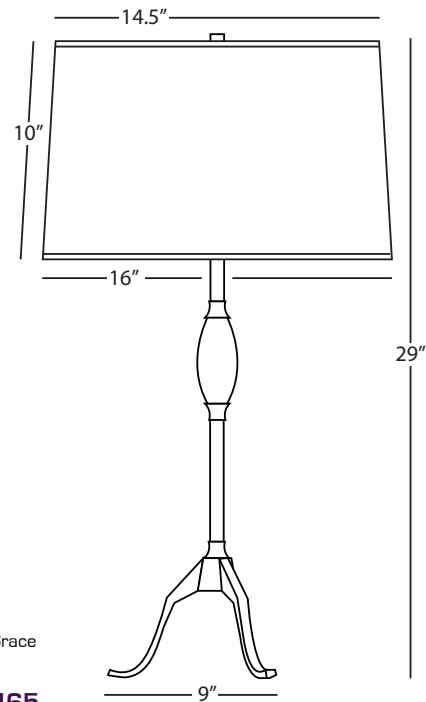
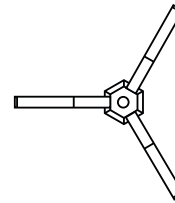

Grace

465

Table Lamp

1 - 150W Max.
Bulb Type: A
Switch: Full Range Dimmer
Modern Brass Finish
Oyster Linen Shade

FINISH OPTIONS:

S465 Polished Nickel
Z465 Deep Patina Bronze



419



S419

Gravity

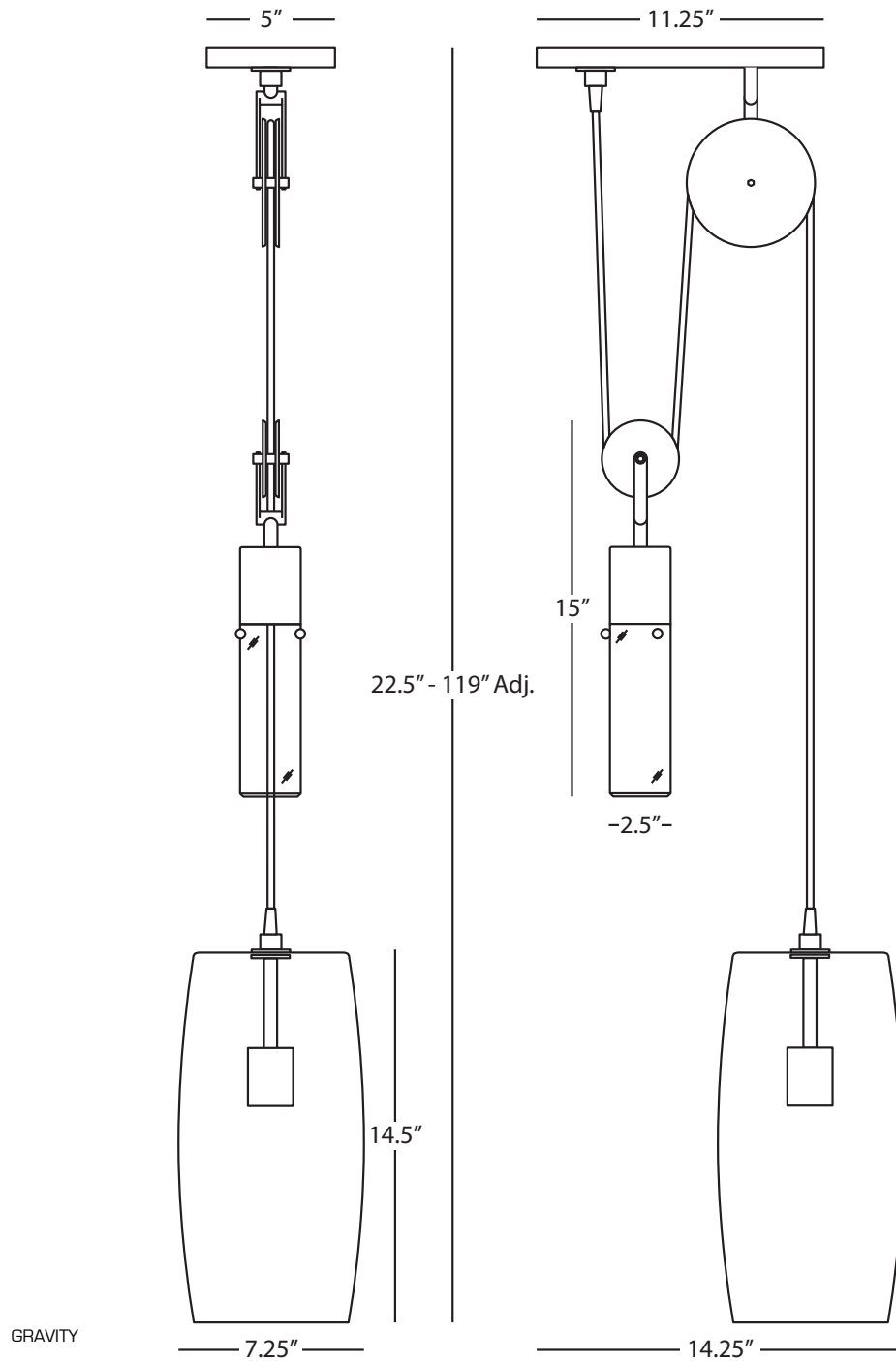

419

Counterweight Pendant

1 - 100W Max.
Bulb Type: A
Direct Wire
Modern Brass Finish w/
Clear Crystal Counterweight
Clear Glass Shade
Susp. Hardware: 12 Ft. Black Fabric Wrapped Cord

Photographed with Historical Bulb
SOLD SEPARATELY
(HISD1 See Page 225)

FINISH OPTION:
S419 Polished Nickel



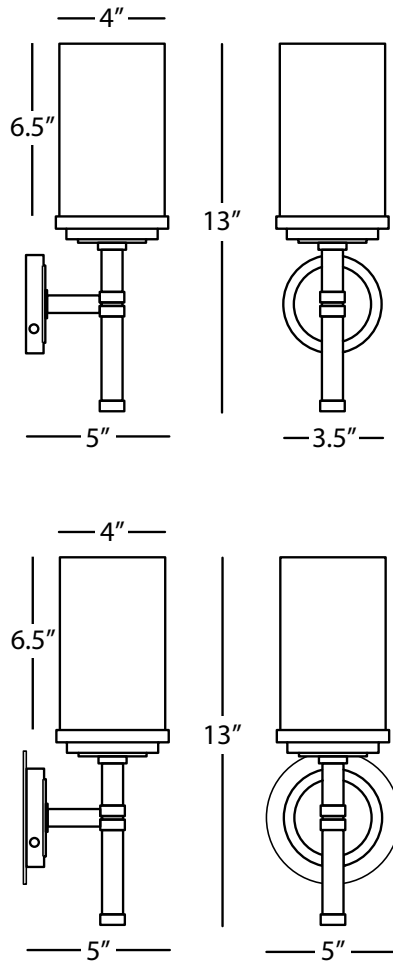

Shown with Optional Junction Box Cover Plate

HALO

1324

Single Sconce

1 - 60W Max.
Bulb Type: A
Direct Wire Only
Brushed Brass Finish w/
Polished Brass Accents
Cased White Glass Shade

FINISH OPTIONS:

B1324 Brushed Nickel w/
Polished Nickel Accents
C1324 Brushed Chrome w/
Polished Chrome Accents

*Metal Junction Box Cover Plate in Matching Finish Included



AM990



AP990



EG990



ST995



MB995

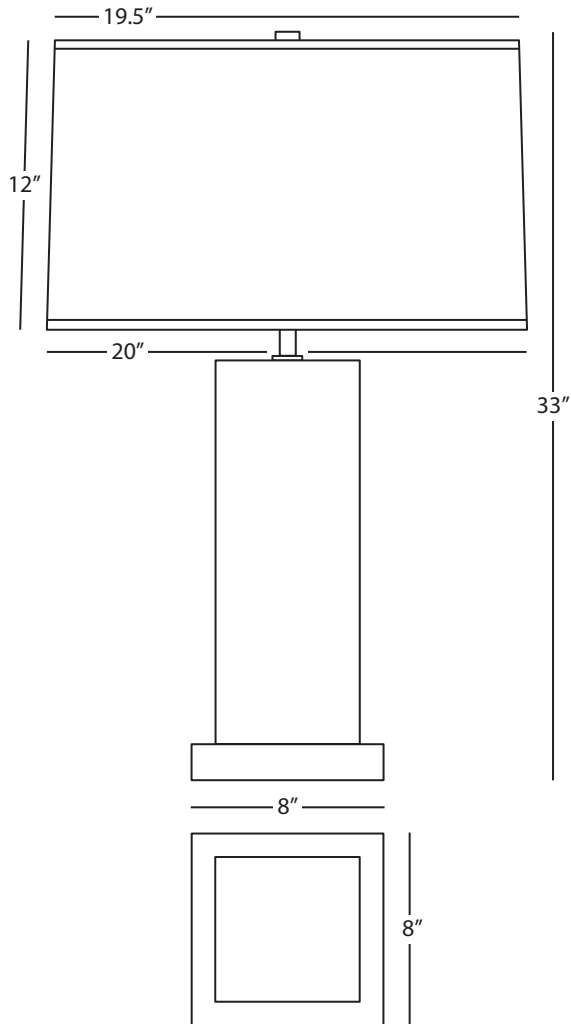

HARVEY

AM990

Accent Lamp

1 - 60W Max.
Bulb Type: G16.5, Candelabra
Switch: Hi-Lo Line Switch
Amethyst Glazed Ceramic
Lucite Base
Oyster Linen Shade w/
Self-Fabric Top Diffuser

See Page 248 for Color Options

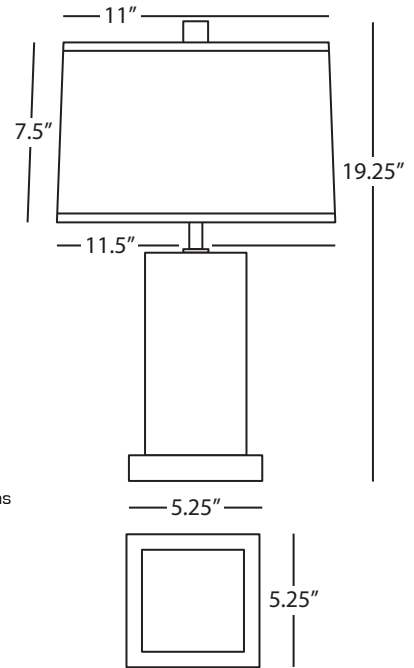

HARVEY

MB995

Table Lamp

1 - 150W Max.
Bulb Type: A
Switch: Hi-Lo Dimming
Midnight Blue Glazed Ceramic
Lucite Base
Oyster Linen Shade

See Page 501 for Color Options

Horizon



Horizon

[Click photo above to watch Horizon Task Floor Lamp Video](#)

A modern spin on classic beehive glass, the Horizon collection features charming contours that have sculptural appeal while remaining airy and light. Available in both clear and smoke gray glass, Horizon is an ideal choice for making a beautiful statement in your home.

| Horizon



Horizon

[Click photo above to watch Horizon Table Lamp Video](#)

A modern spin on classic beehive glass, the Horizon collection features charming contours that have sculptural appeal while remaining airy and light. Available in both clear and smoke gray glass, Horizon is an ideal choice for making a beautiful statement in your home.

| Horizon



Horizon

[Click photo above to watch Horizon Accent Lamp Video](#)

A modern spin on classic beehive glass, the Horizon collection features charming contours that have sculptural appeal while remaining airy and light. Available in both clear and smoke gray glass, Horizon is an ideal choice for making a beautiful statement in your home.

| Horizon



Horizon

[Click photo above to watch Horizon Task Table Lamp Video](#)

A modern spin on classic beehive glass, the Horizon collection features charming contours that have sculptural appeal while remaining airy and light. Available in both clear and smoke gray glass, Horizon is an ideal choice for making a beautiful statement in your home.



CL62



CL60



GY61



GY63

Horizon

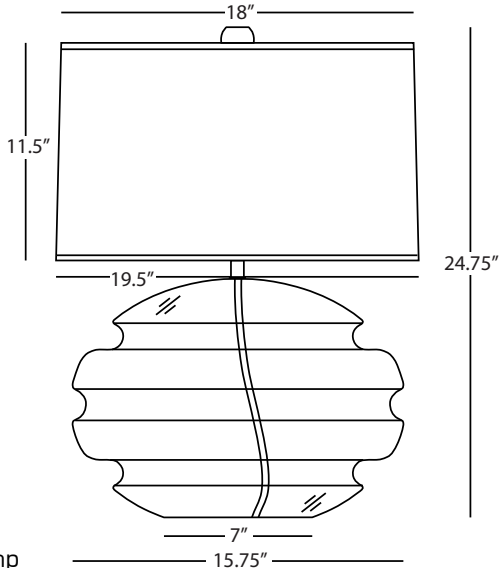

HORIZON

CL60 Table Lamp

1 - 150W Max.
Bulb Type: A
Switch: Full Range Dimmer
Clear Glass Body w/
Modern Brass Accents
Oyster Linen Shade w/
Self Fabric Top Diffuser
Black Fabric Wrapped Cord

FINISH OPTION:
GY60 Smoke Gray Glass

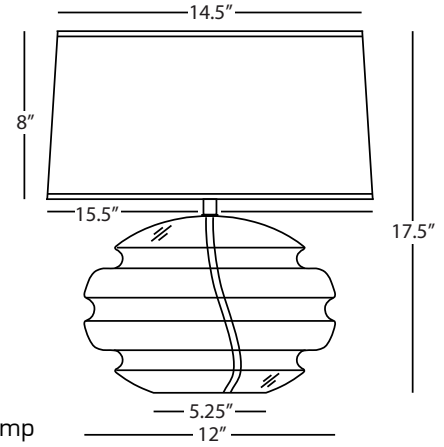

HORIZON

GY61 Accent Lamp

1 - 60W Max.
Bulb Type: A
Switch: Full Range Dimmer
Smoke Grey Glass Body w/
Modern Brass Accents
Oyster Linen Shade w/
Self Fabric Top Diffuser
Black Fabric Wrapped Cord

FINISH OPTION:
CY61 Clear Glass

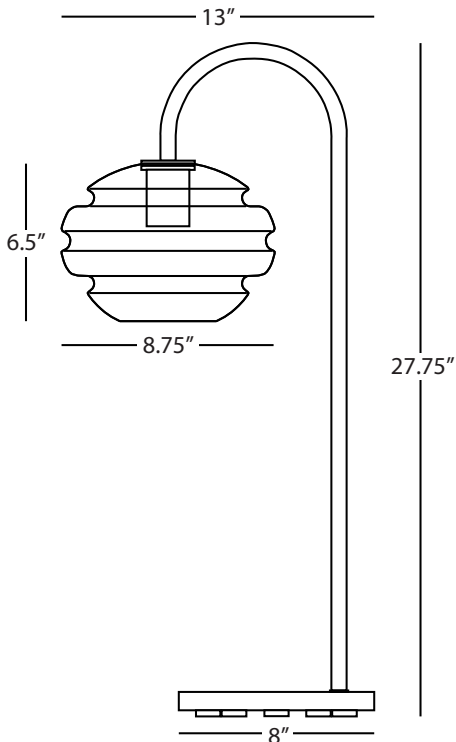

HORIZON

CL62 Task Table Lamp

1 - 60W Max.
Bulb Type: A
Switch: Full Range Dimmer Line Switch
Modern Brass Finish
Clear Glass Shade

FINISH OPTION:
GY62 Smoke Gray Glass

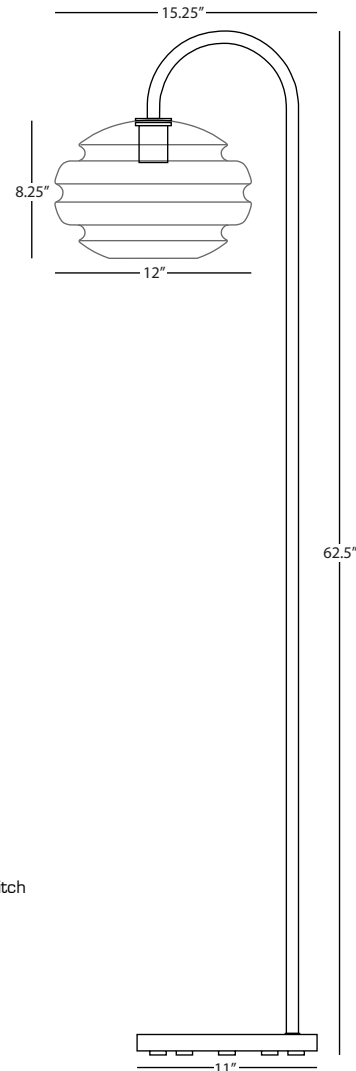

HORIZON

GY63 Task Floor Lamp

1 - 100W Max.
Bulb Type: G, Medium Base
Switch: Full Range Dimmer Line Switch
Modern Brass Finish
Smoke Gray Glass Shade

FINISH OPTION:
CL63 Clear Glass

| Horizon



Horizon

[Click photo above to watch Horizon Flush Mount Video](#)

A modern spin on classic beehive glass, the Horizon collection features charming contours that have sculptural appeal while remaining airy and light. Available in both clear and smoke gray glass, Horizon is an ideal choice for making a beautiful statement in your home.

Horizon



Horizon

[Click photo above to watch Horizon Pendant Video](#)

A modern spin on classic beehive glass, the Horizon collection features charming contours that have sculptural appeal while remaining airy and light. Available in both clear and smoke gray glass, Horizon is an ideal choice for making a beautiful statement in your home.



GY65



CL64



GY64



CL65

Horizon

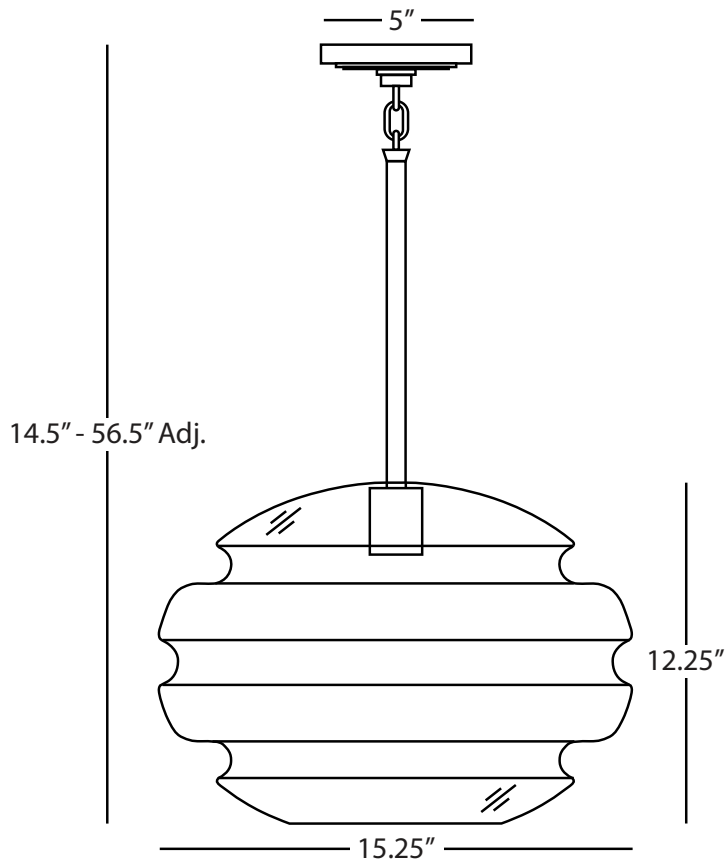

HORIZON

CL65

Pendant

1 - 150W Max.

Bulb Type: G, Medium Base

Direct Wire

Clear Glass Shade w/

Modern Brass Accents

Susp. Hardware: 3 pcs. 5/8" x 12" &

1 pc. 5/8" x 6" Extensions

FINISH OPTION:

GY65 Smoke Gray Glass

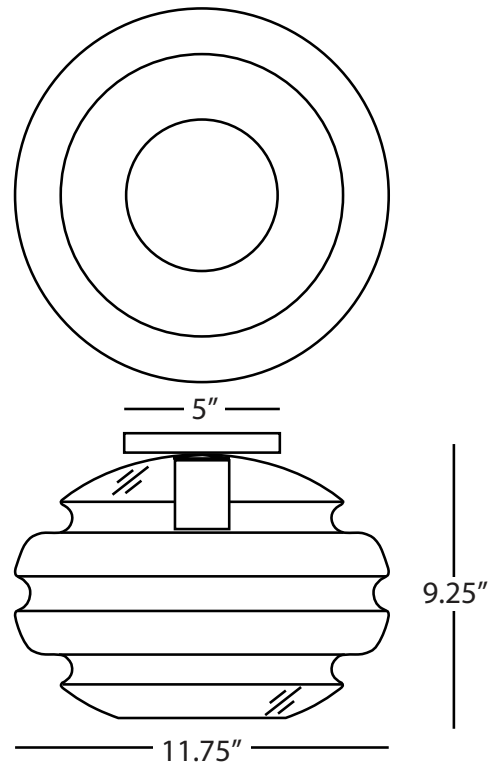

HORIZON

CL64

Flush Mount

1 - 100W Max.

Bulb Type: G, Medium Base

Direct Wire

Clear Glass Shade w/

Modern Brass Accents

FINISH OPTION:

GY64 Smoke Gray Glass

| Horizon



Horizon



[Click photo above to watch Horizon video](#)

A modern spin on classic beehive glass, the Horizon collection features charming contours that have sculptural appeal while remaining airy and light.



CL66



GY66

Horizon

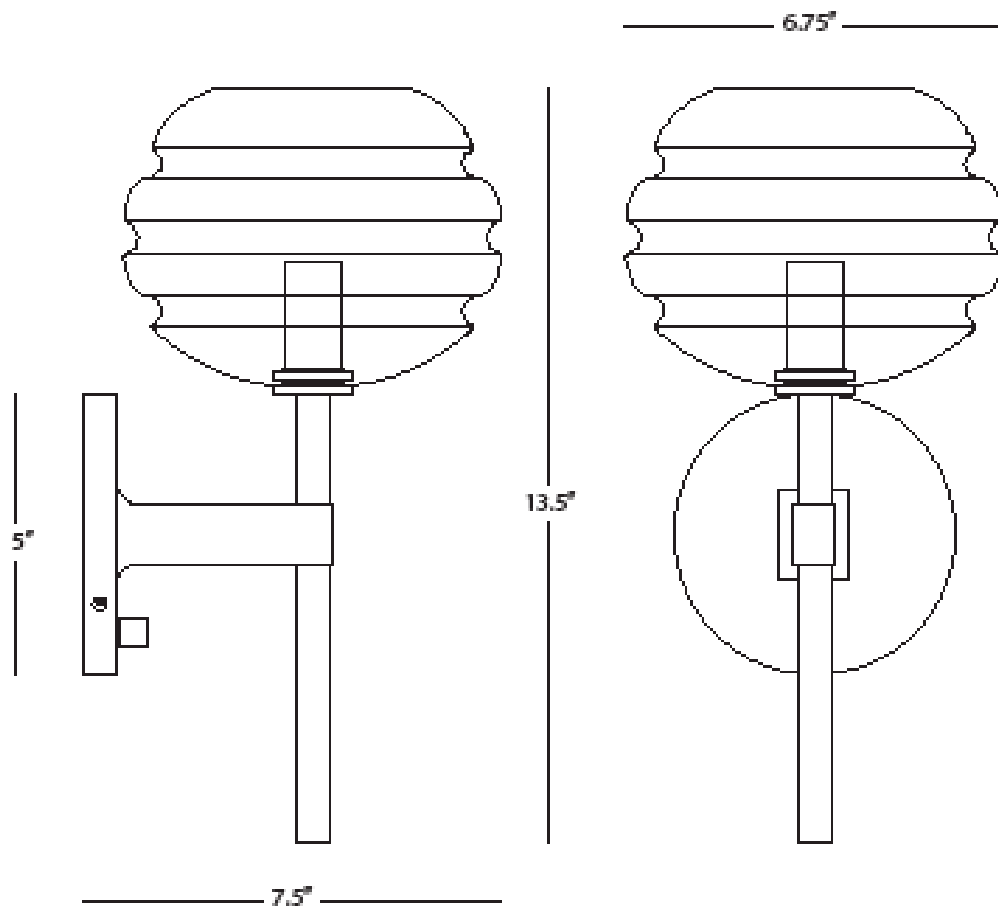

HORIZON

CL66

Wall Sconce

1 - 60W Max.
Bulb Type: G, Candelabra Base
Switch: Full Range Dimmer
24" Cord Cover/Direct Wire
Clear Glass Shade
UL Rated Damp Locations

SHADE OPTIONS:

GY66 Smoke Gray Glass



MR210



EG210



AP210



AM210



EB210

Jasmine

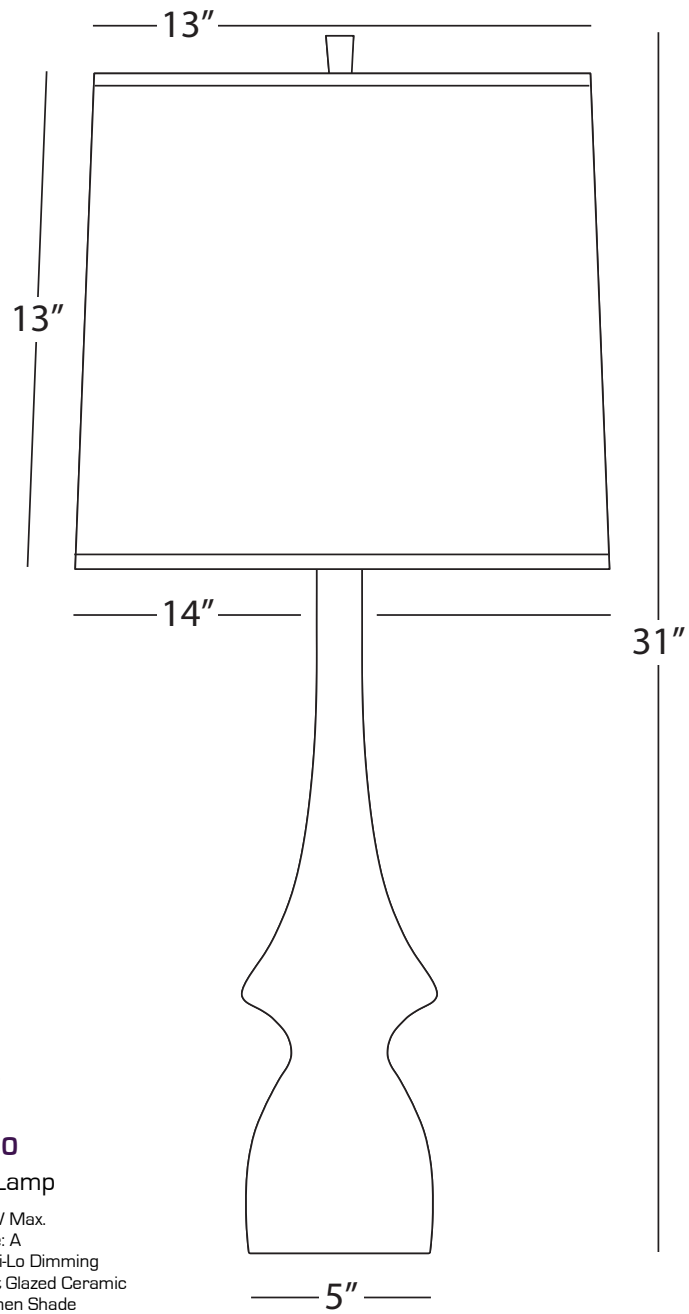

JASMINE

AM210

Table Lamp

1 - 150W Max.

Bulb Type: A

Switch: Hi-Lo Dimming

Amethyst Glazed Ceramic

Oyster Linen Shade

See Page 500 for Color Options



209B



S209

Jeannie

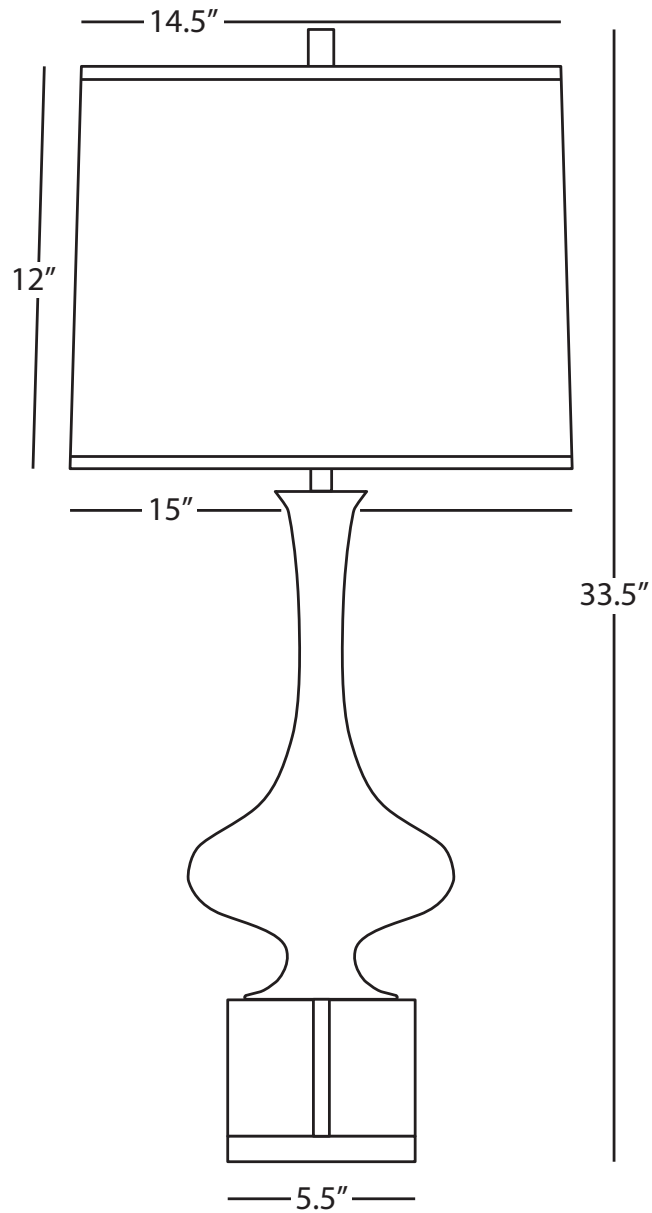

JEANNIE

209B

Table Lamp

1 - 150W Max.

Bulb Type: A

Switch: Full Range Dimmer

Modern Brass Finish

Clear Crystal Base

Black Opaque Parchment Shade w/ Gold Lining

FINISH/ SHADE OPTIONS:

209 Modern Brass/ Fondine Shade

S209 Polished Nickel/ Fondine Shade

S209B Polished Nickel/ Black Parchment w/ Silver Lining



CL993



BT93



BB91



ST991

JUNE

BB91

Accent Lamp

1 - 150W Max.
Bulb Type: A
Switch: Full Range Dimmer Line Switch
Baby Blue Glazed Ceramic
Buff Linen Shade

See Page 502 for Color/Shade Options

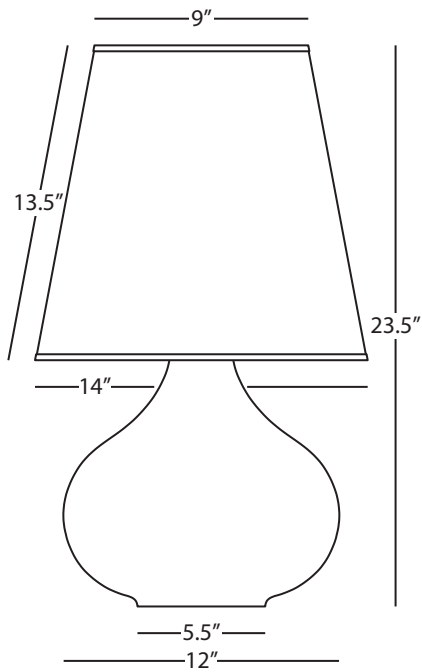

JUNE

CL993

Table Lamp

1 - 150W Max.
Bulb Type: A
Switch: Hi-Lo Dimming
Celadon Glazed Ceramic
Oyster Linen Shade

See Page 502 for Color/Shade Options

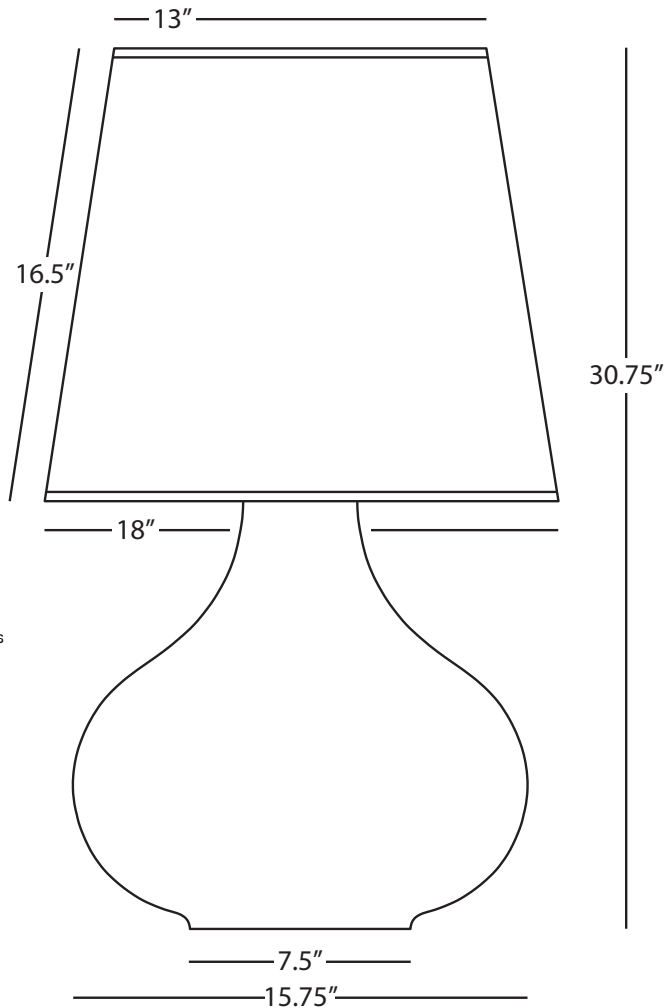



458B



459W

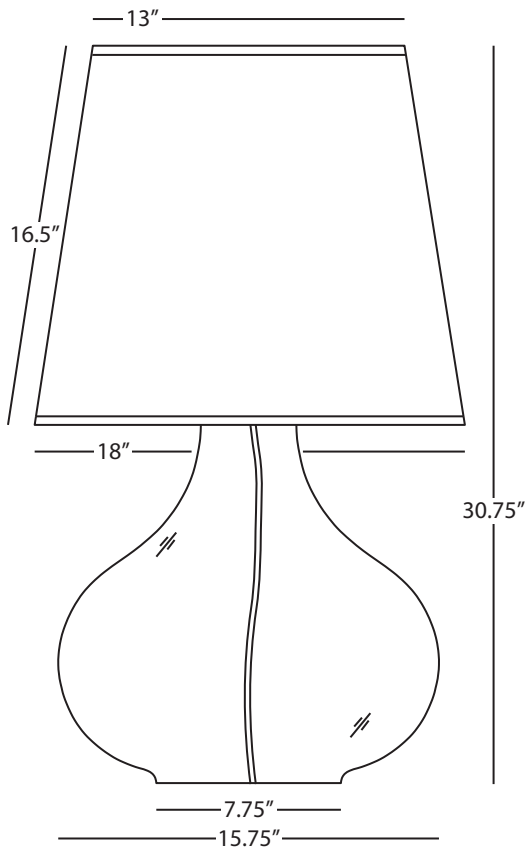

JUNE

459W

Glass Table Lamp

1 - 150W Max.
 Bulb Type: A
 Switch: Full Range Dimmer Line Switch
 Clear Glass Body
 Black Fabric Wrapped Cord
 White Organza Fabric Shade

SHADE OPTION:

459B Black Organza

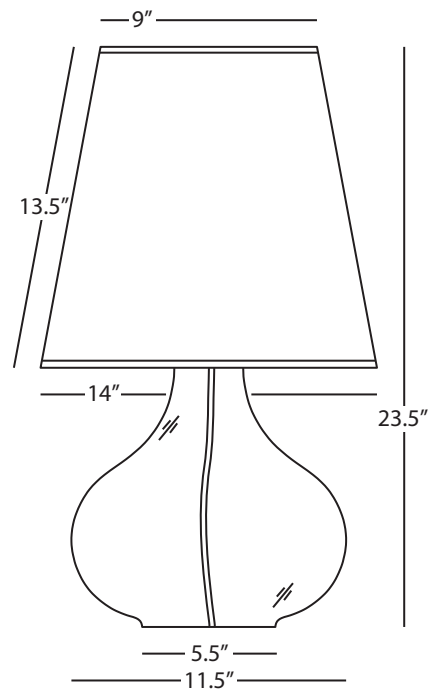

JUNE

458B

Glass Accent Lamp

1 - 150W Max.
 Bulb Type: A
 Switch: Full Range Dimmer Line Switch
 Clear Glass Body
 Black Fabric Wrapped Cord
 Black Organza Fabric Shade

SHADE OPTION:

458W White Organza



207



S207B

Juno

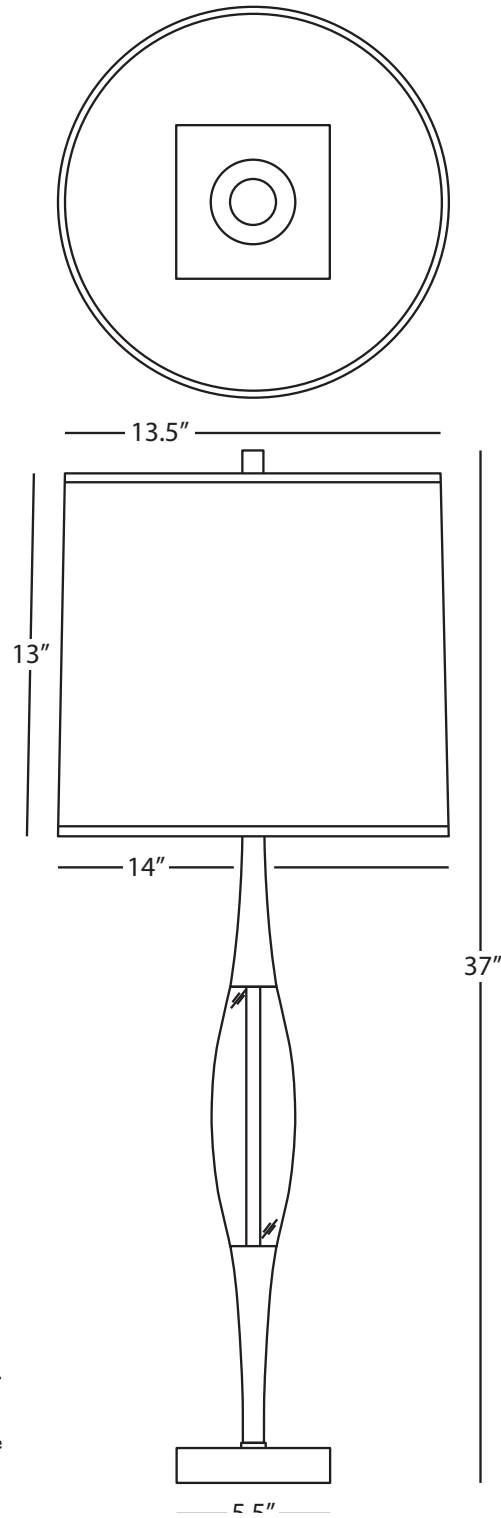

JUNO

207 Table Lamp

1 - 150W Max.
Bulb Type: A
Switch: Full Range Dimmer
Modern Brass Finish w/
Clear Crystal Accent
Pearl Dupioni Fabric Shade
USB Port on Base

FINISH/SHADE OPTIONS:

- 207B** Modern Brass/Black Parchment
w/ Matte Gold Lining
- S207** Polished Nickel/Pearl Dupioni
- S207B** Polished Nickel/Black Parchment
w/ Matte Silver Lining



PG203



VW203



AW202



SG202

Kate

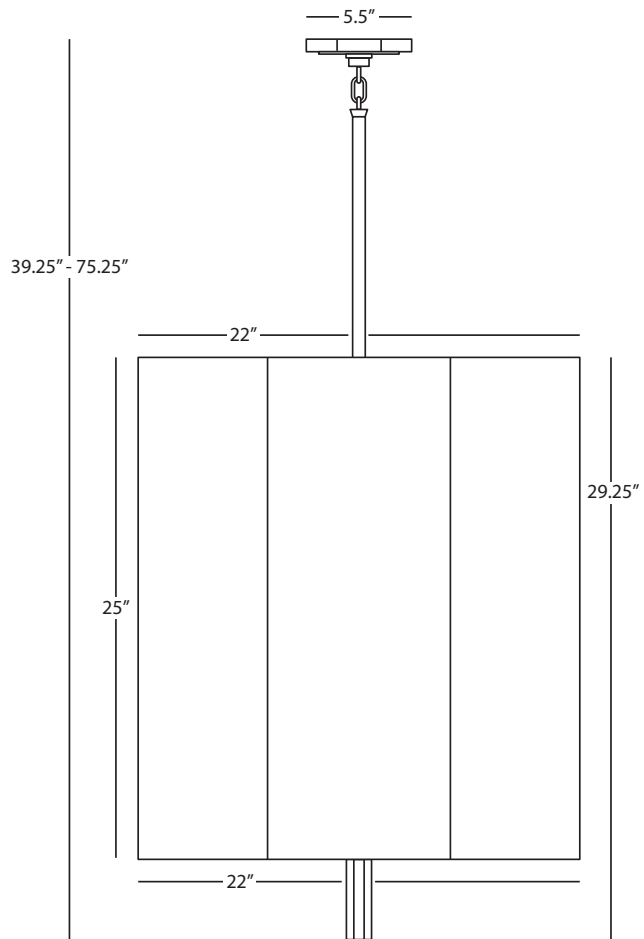
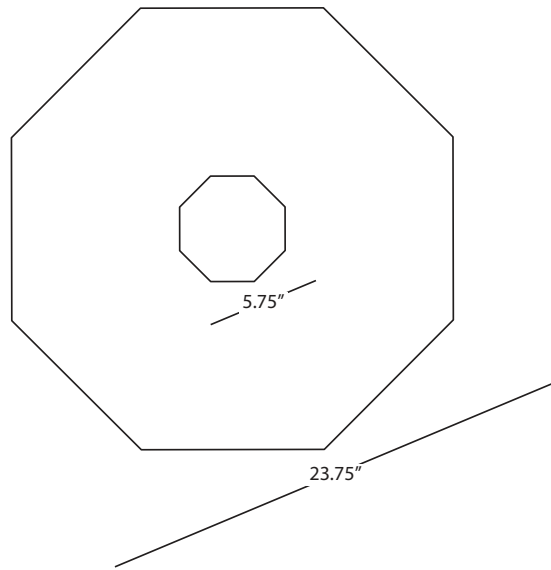

KATE

AW202

Pendant

6 - 100W Max.

Bulb Type: A

Direct Wire

Modern Brass Finish w/

Clear Crystal Finial

Octagonal Ascot White Fabric Shade

Susp. Hardware: 1 pc. 5/8" x 6" & 3 pcs. 5/8" x 12" Extensions

FINISH/SHADE OPTIONS:

- | | |
|--------------|------------------------------|
| PG202 | Modern Brass/Pearl Gray |
| RB202 | Modern Brass/Raven Black |
| SG202 | Modern Brass/Smoke Gray |
| VW202 | Modern Brass/Vintage Wine |
| AW203 | Polished Nickel/Ascot White |
| PG203 | Polished Nickel/Pearl Gray |
| RB203 | Polished Nickel/Raven Black |
| SG203 | Polished Nickel/Smoke Gray |
| VW203 | Polished Nickel/Vintage Wine |

Kate



Kate

[Click photo above to watch Kate Table Lamp Video](#)

Make a bold statement in your space with the Kate collection from Robert Abbey! Featuring an oversized, octagonal shade and a dazzling crystal accent, Kate is certainly impressive. Kate is a fresh take on classic design.

Kate



Kate

[Click photo above to watch Kate Floor Lamp Video](#)

Make a bold statement in your space with the Kate collection from Robert Abbey! Featuring an oversized, octagonal shade and a dazzling crystal accent, Kate is certainly impressive. Kate is a fresh take on classic design.



SG07



PG04



VW04



AW07

Kate

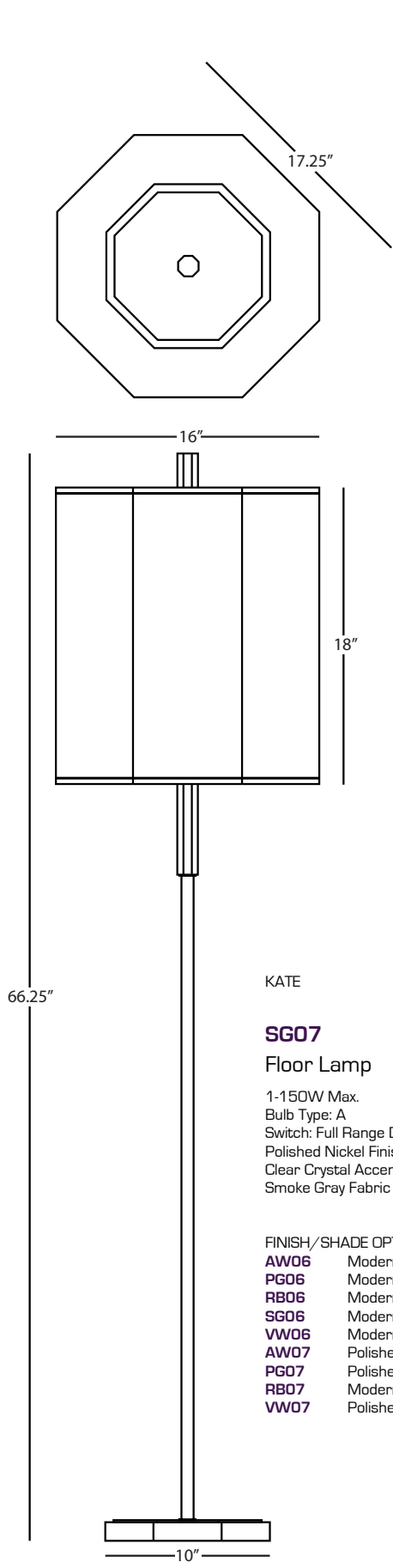

KATE

SG07
Floor Lamp

1-150W Max.
Bulb Type: A
Switch: Full Range Dimmer
Polished Nickel Finish w/
Clear Crystal Accents
Smoke Gray Fabric Shade

- FINISH/SHADE OPTIONS:
- AW06** Modern Brass/ Ascot White
 - PG06** Modern Brass/ Pearl Gray
 - RB06** Modern Brass/ Raven Black
 - SG06** Modern Brass/ Smoke Gray
 - VW06** Modern Brass/ Vintage Wine
 - AW07** Polished Nickel/ Ascot White
 - PG07** Polished Nickel/ Pearl Gray
 - RB07** Modern Brass/ Raven Black
 - VW07** Polished Nickel/ Vintage Wine

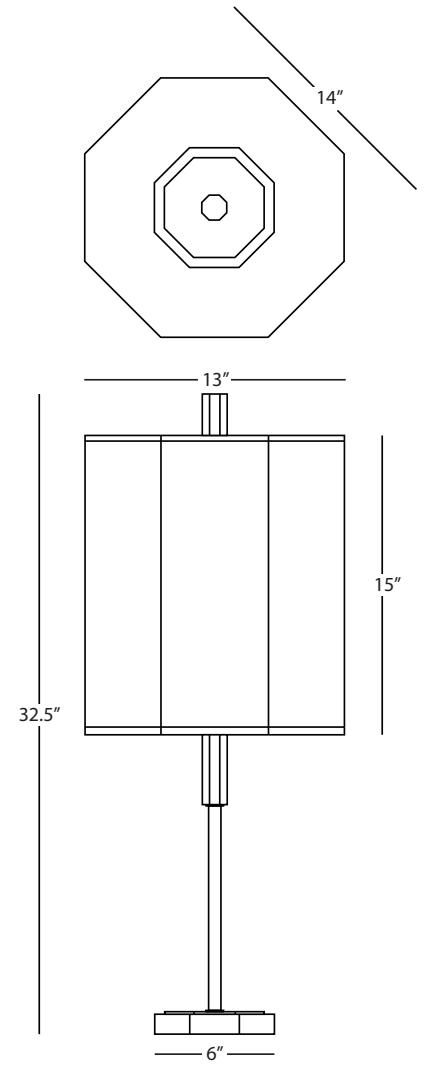

KATE

VW04
Table Lamp

1-150W Max.
Bulb Type: A
Switch: Full Range Dimmer
Modern Brass Finish w/
Clear Crystal Accents
Vintage Wine Fabric Shade

- FINISH/SHADE OPTIONS:
- AW04** Modern Brass/ Ascot White
 - PG04** Modern Brass/ Pearl Gray
 - RB04** Modern Brass/ Raven Black
 - SG04** Modern Brass/ Smoke Gray
 - AW05** Polished Nickel/ Ascot White
 - PG05** Polished Nickel/ Pearl Gray
 - RB05** Polished Nickel/ Pearl Gray
 - SG05** Polished Nickel/ Smoke Gray
 - VW05** Polished Nickel/ Vintage Wine

| Kate



Kate

[Click photo above to watch Kate Pendant Video](#)

Make a bold statement in your space with the Kate collection from Robert Abbey! Featuring an oversized, octagonal shade and a dazzling crystal accent, Kate is a fresh take on classic design.



RB202

RB05



RB06

Kate

Kate

RB202 Pendant

6 - 100W Max.
Bulb Type: A
Direct Wire
Modern Brass Finish
Clear Crystal Finial
Raven Black Fabric Shade
Susp. Hardware: 1 pc. 5/8" x 6" &
3 pcs. 5/8" X 12" Extension Rods

FINISH OPTIONS:

AW202 Modern Brass/Ascot White
PG202 Modern Brass/Pearl Gray
SG202 Modern Brass/Smoke Gray
VW202 Modern Brass/Vintage Wine
AW203 Polished Nickel/Ascot White
PG203 Polished Nickel/Pearl Gray
RB203 Polished Nickel/Raven Black
SG203 Polished Nickel/Smoke Gray
VW203 Polished Nickel/Vintage Wine

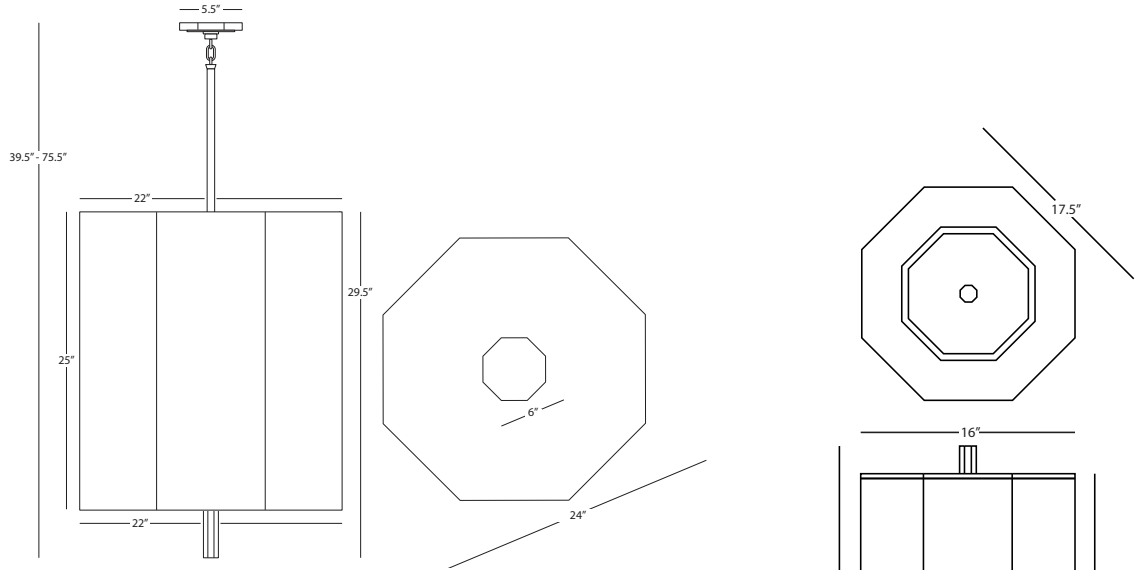

Kate

RB05 Table Lamp

1 - 150W Max.
Bulb Type: A
Switch: Full Range Dimmer
Polished Nickel Finish
Clear Crystal Finial
Raven Black Fabric Shade

FINISH OPTIONS:

AW04 Modern Brass/Ascot White
PG04 Modern Brass/Pearl Gray
RB04 Modern Brass/Raven Black
SG04 Modern Brass/Smoke Gray
VW04 Modern Brass/Vintage Wine
AW05 Polished Nickel/Ascot White
PG05 Polished Nickel/Pearl Gray
SG05 Polished Nickel/Smoke Gray
VW05 Polished Nickel/Vintage Wine

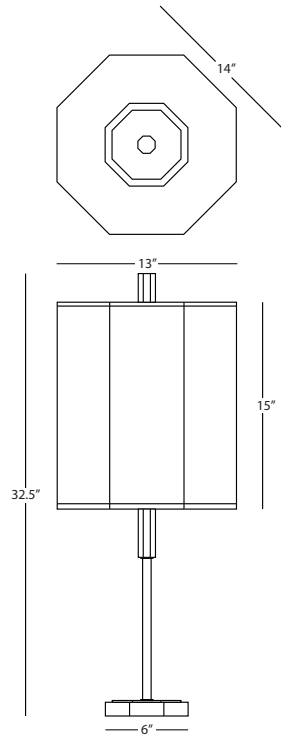

Kate

RB06 Floor Lamp

1 - 150W Max.
Bulb Type: A
Switch: Full Range Dimmer
Modern Brass Finish
Clear Crystal Finial
Raven Black Fabric Shade

FINISH OPTIONS:

AW06 Modern Brass/Ascot White
PG06 Modern Brass/Pearl Gray
SG06 Modern Brass/Smoke Gray
VW06 Modern Brass/Vintage Wine
AW07 Polished Nickel/Ascot White
PG07 Polished Nickel/Pearl Gray
RB07 Polished Nickel/Raven Black
SG07 Polished Nickel/Smoke Gray
VW07 Polished Nickel/Vintage Wine

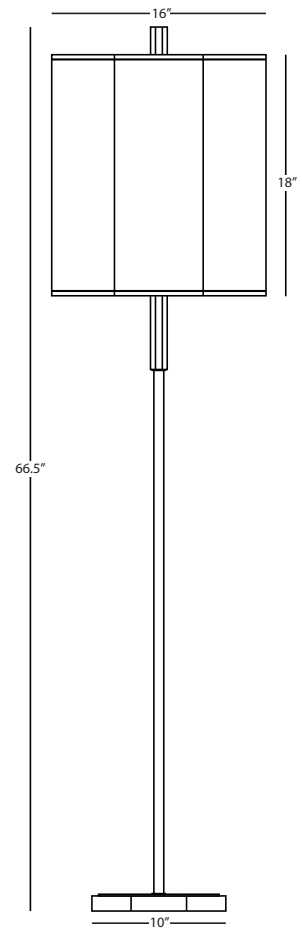



1505



Z1504DBZ



Z1504ALT



B1504ALT



1500

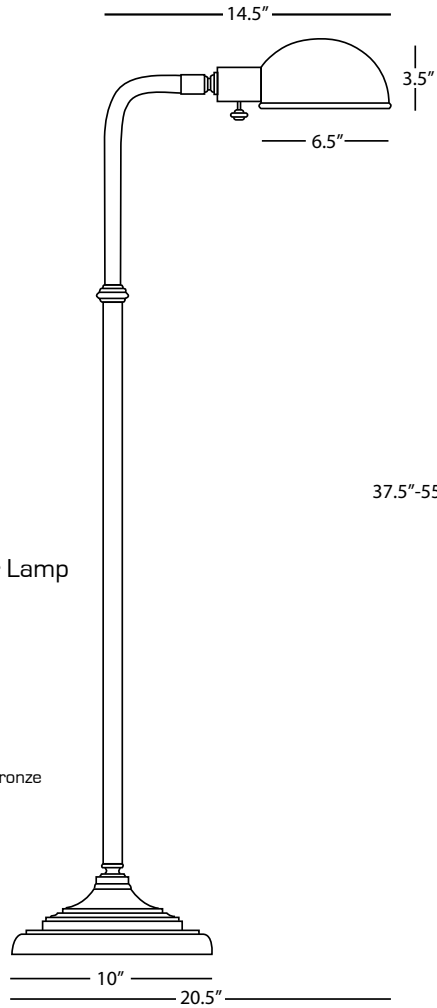

KINETIC

1505 Adjustable Task Floor Lamp

1 - 60W Max.
Bulb Type: A
Switch: Hi-Lo Dimming
Antique Brass Finish
Metal Shade

FINISH OPTION:
Z1505DBZ Deep Patina Bronze

37.5" - 55.75" Adj.

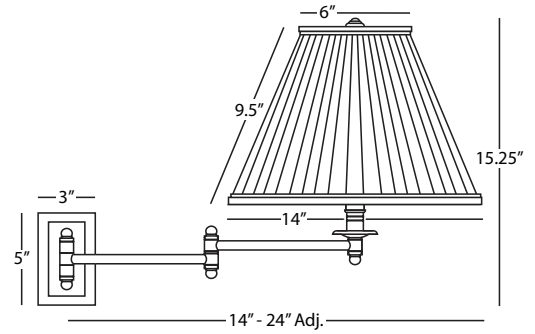

KINETIC

B1504ALT Swing Arm Sconce

1 - 150W Max.
Bulb Type: A
Switch: 3-Way
24" Cord Cover/Direct Wire
Brushed Chrome Finish
Oyster Linen Fabric Shade

FINISH/SHADE OPTIONS:

1504	Antique Brass Natural Side Pleat Fabric
1504ALT	Antique Brass Oyster Linen
1504X	Antique Brass Ascot Bone Fabric
B1504XXX	Brushed Chrome Ascot White Fabric
Z1504ALT	Deep Patina Bronze Oyster Linen
Z1504DBZ	Deep Patina Bronze Natural Side Pleat Fabric
Z1504XXX	Deep Patina Bronze Translucent Flax Parchment

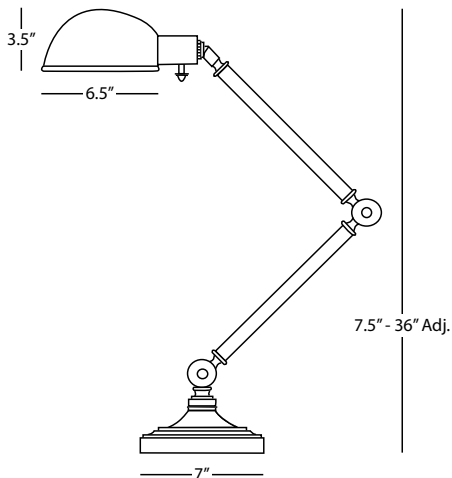

KINETIC

1500 Adjustable Task Table Lamp

1 - 60W Max.
Bulb Type: A
Switch: Hi-Lo Dimming
Antique Brass Finish
Metal Shade

7.5" - 36" Adj.



Koleman

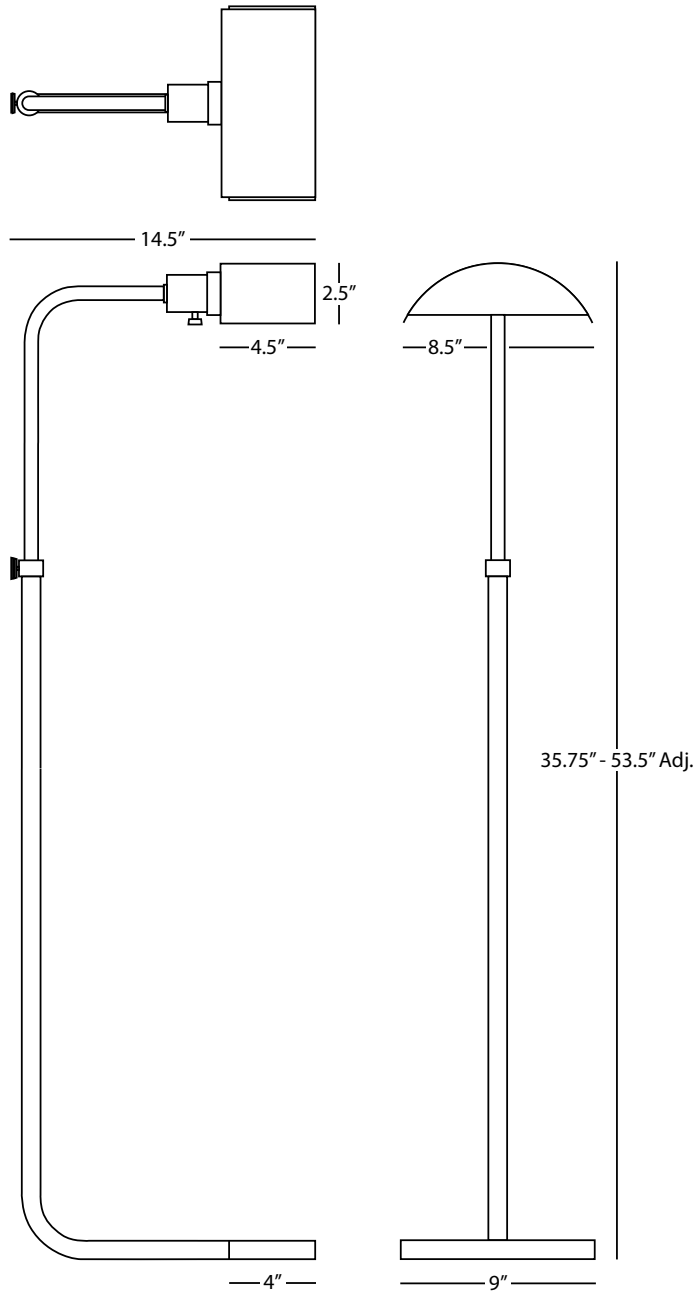

KOLEMAN

S461

Adjustable Task Floor Lamp

1 - 60W Max.
 Bulb Type: B11, Torpedo
 Switch: Hi-Lo Dimming
 Polished Nickel Finish
 Metal Shade

FINISH OPTIONS:

- 461** Aged Brass
- Z461** Deep Patina Bronze

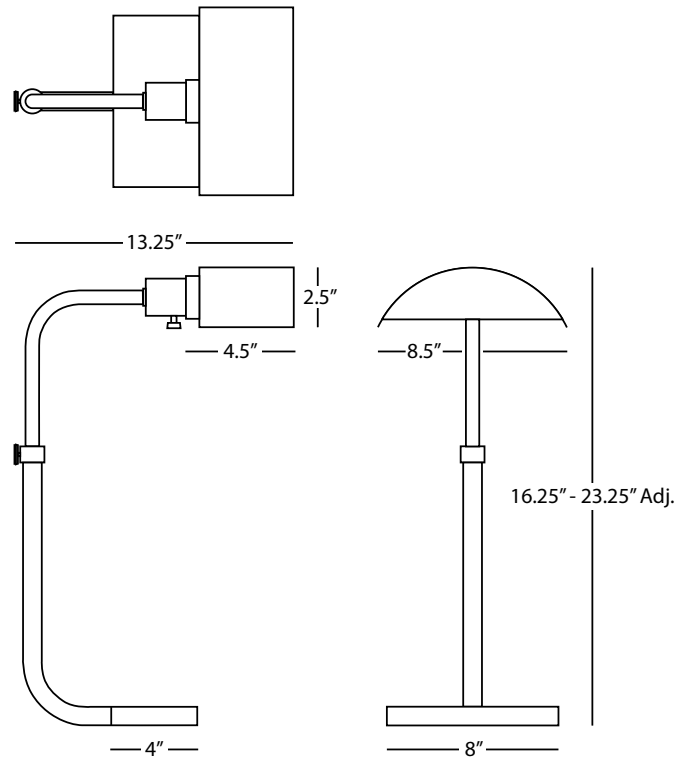

KOLEMAN

Z460

Adjustable Task Table Lamp

1 - 60W Max.
 Bulb Type: B11, Torpedo
 Switch: Hi-Lo Dimming
 Deep Patina Bronze Finish
 Metal Shade

FINISH OPTIONS:

- 460** Aged Brass
- S460** Polished Nickel



463



S464



Z462

Koleman

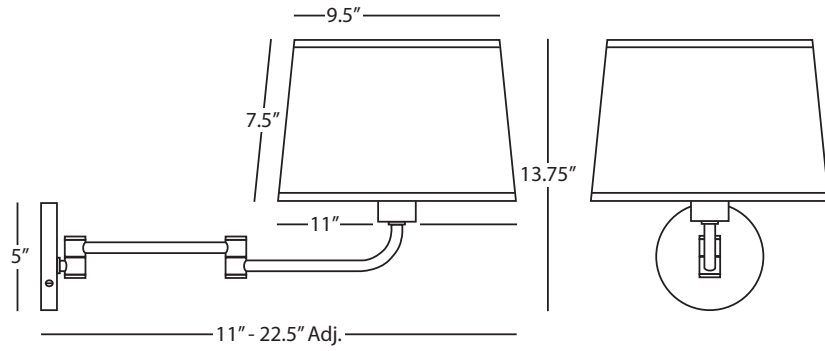

KOLEMAN

S464 Swing Arm Sconce

1 - 100W Max.
Bulb Type: A
Switch: Hi-Lo Dimming
24" Cord Cover / Direct Wire
Polished Nickel Finish
Oyster Linen Shade

FINISH OPTIONS:

464 Aged Brass
Z464 Deep Patina Bronze

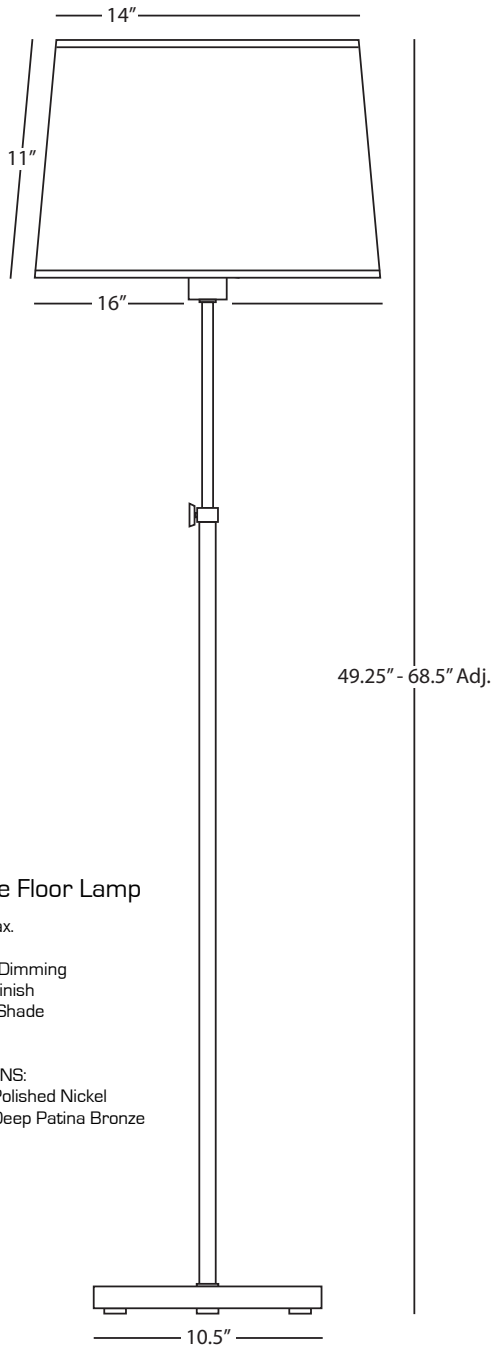

KOLEMAN

463 Adjustable Floor Lamp

1 - 100W Max.
Bulb Type: A
Switch: Hi-Lo Dimming
Aged Brass Finish
Oyster Linen Shade

FINISH OPTIONS:

S463 Polished Nickel
Z463 Deep Patina Bronze

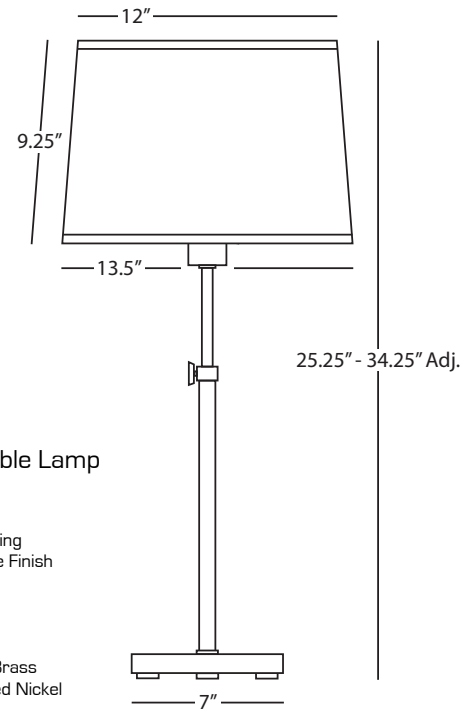

KOLEMAN

Z462 Adjustable Table Lamp

1 - 100W Max.
Bulb Type: A
Switch: Hi-Lo Dimming
Deep Patina Bronze Finish
Oyster Linen Shade

FINISH OPTIONS:

462 Aged Brass
S462 Polished Nickel



3373



3374

Latitude

LATITUDE

3373

Pendant

1 - 100W Max.
Bulb Type: A
Direct Wire
Aged Brass Finish w/ Clear Glass Accents
Susp. Hardware: 1 pc. 5/8" x 6" & 3 pcs.
5/8" x 12" Extensions

Ships w/ 1 - 30W Filament Bulb

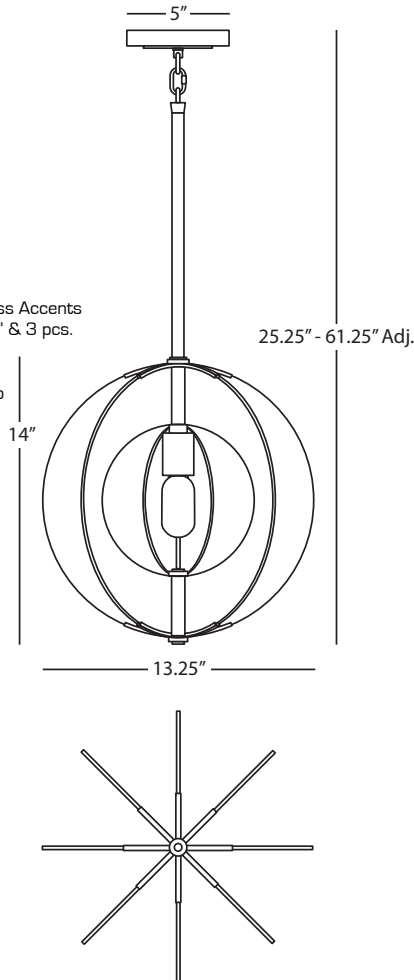

LATITUDE

3374

Wall Sconce

1 - 60W Max.
Bulb Type: B10 Candelabra
Switch: Hi-Lo Line Switch
24" Cord Cover/Direct Wire
Aged Brass Finish w/ Clear Glass Accents
Oyster Grey Silk Shade w/ Gold Foil Lining

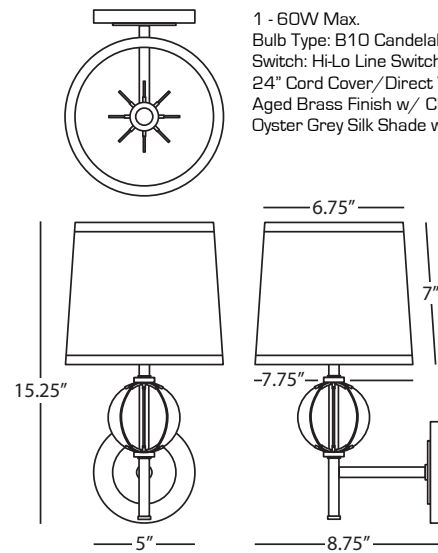



1341

1340

Ledger

LEDGER

1340

Table Lamp

1 - 60W Max.
Bulb Type: B, Candelabra
Switch: 4-Way Touch Switch
Warm Brass Finish w/
Dark Walnut Accents
Metal Shade
USB Port on Base

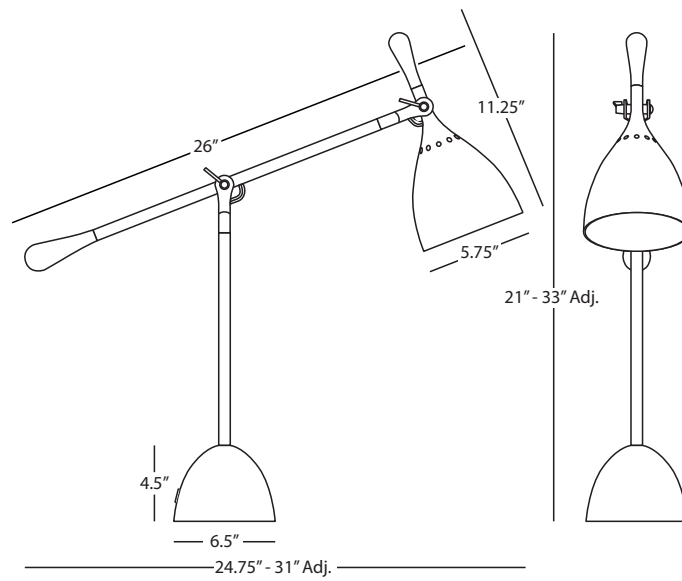

LEDGER

1341

Floor Lamp

1 - 60W Max.
Bulb Type: A
Switch: Full Range Dimmer Line Switch
Warm Brass Finish w/
Dark Walnut Accents
Metal Shade

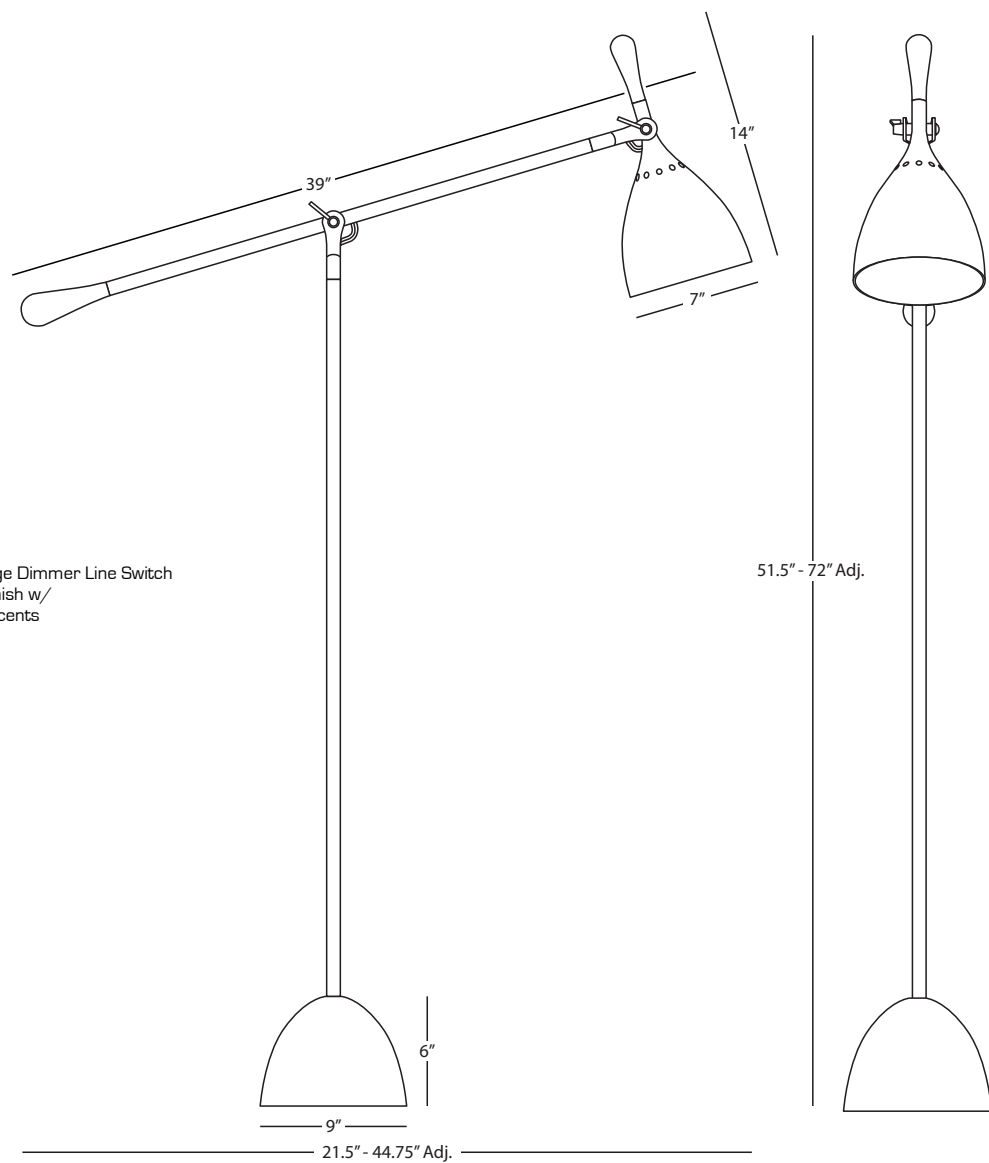

Lincoln



Lincoln

[Click photo above to watch Lincoln Table Lamp video](#)

Clear crystal and sturdy modern brass accents give the Lincoln collection a handsome yet ethereal presence. Lincoln is perfect for creating a sense of balance and harmony in contemporary spaces.



1012



1009



1020B

Lincoln

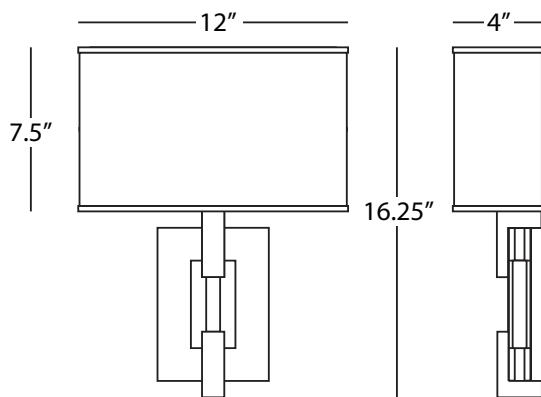

Lincoln

1009 Wall Sconce

2 - 40W Max.
Bulb Type: B (Medium Base)
Direct Wire Only
Modern Brass Finish
Clear Crystal Accents
Pearl Dupioni Silk Fabric Shade

FINISH OPTIONS:

- 1009B** Modern Brass/Opaque Parchment with Matte Gold Lining
- 1010** Polished Nickel/Pearl Dupioni Silk
- 1010B** Polished Nickel/Opaque Parchment with Matte Silver Lining

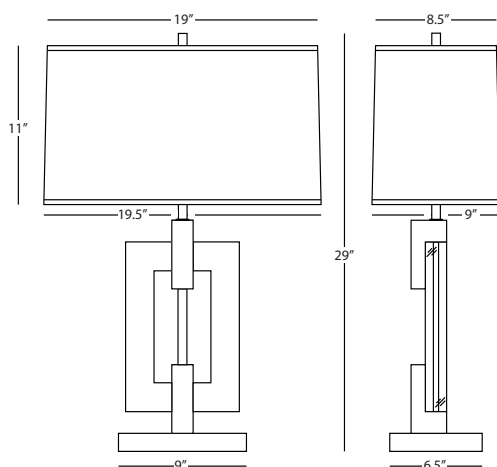

LINCOLN

1012 Table Lamp

1 - 150W Max.
Bulb Type: A
Switch: Full Range Dimmer
Clear Crystal w/ Polished Nickel Accents
Pearl Dupioni Silk Shade

FINISH/SHADE OPTIONS:

- 1011** Modern Brass/Pearl Dupioni Silk
- 1011B** Modern Brass/Black Parchment w/ Matte Gold Lining
- 1012** Polished Nickel/Pearl Dupioni Silk
- 1012B** Polished Nickel/Black Parchment w/ Matte Silver Lining

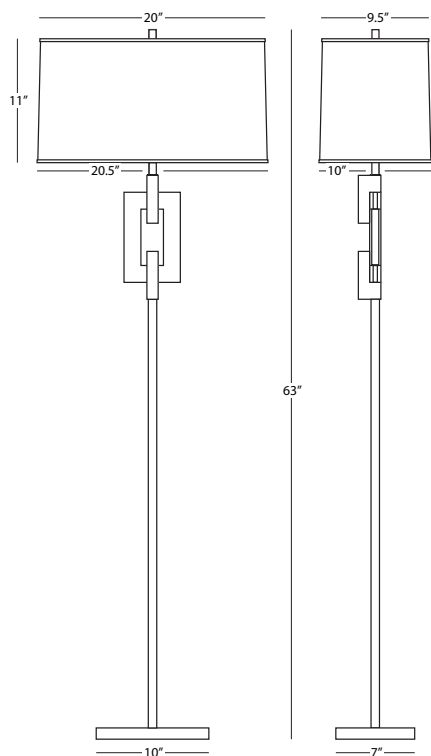

Lincoln

1020B Floor Lamp

1 - 150W Max.
Bulb Type: A
Switch: Full Range Dimmer
Modern Brass Finish
Clear Crystal Accents
Opaque Parchment Shade
With Matte Gold Lining

FINISH OPTIONS:

- 1020** Modern Brass/Pearl Dupioni Silk
- 1021** Polished Nickel/Pearl Dupioni Silk
- 1021B** Polished Nickel/Opaque Parchment with Matte Silver Lining



2792



2295B

Logan

LOGAN

2295B

Table Lamp

1 - 150W Max.
 Bulb Type: A
 Switch: Hi-Lo Dimming
 Aged Brass Finish
 Travertine Stone Base
 Oval Black Painted Opaque Parchment
 Shade w/ Copper Foil Lining

FINISH/SHADE OPTIONS:

- 2295** Aged Brass/Travertine Stone
Oval Fondine Fabric Shade
- 2791** Polished Nickel/Carrara Marble
Ascot White Fabric
- 2791B** Polished Nickel/Carrara Marble
Black Painted Opaque Parchment
w/ Silver Foil Lining

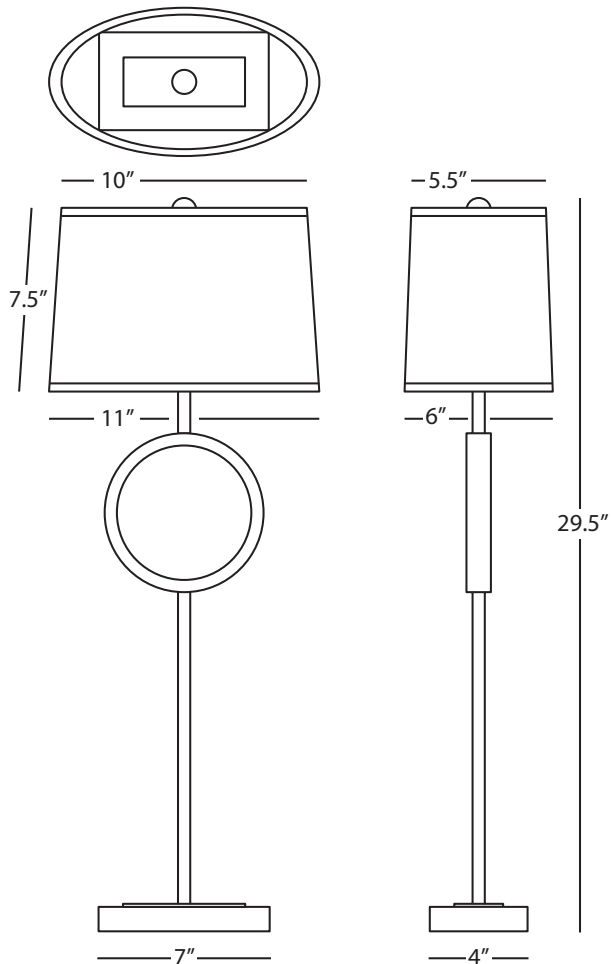
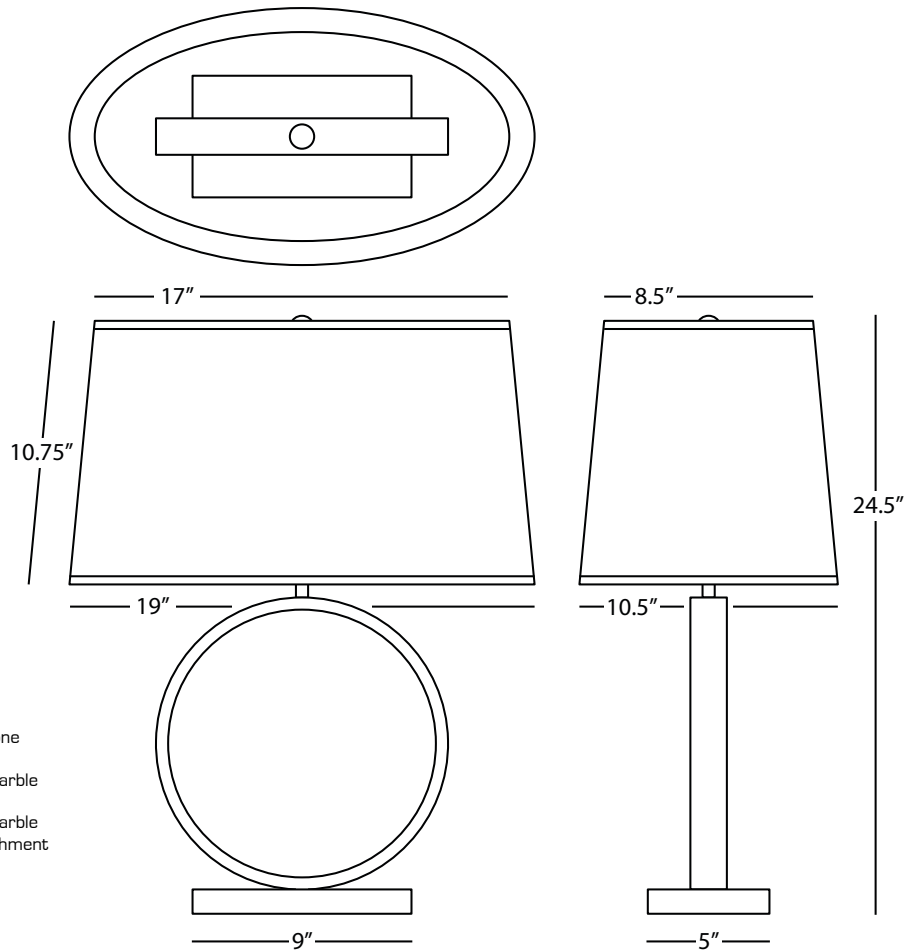

LOGAN

2792

Buffet Table Lamp

1 - 60W Max.
 Bulb Type: B, Candelabra
 Switch: Hi-Lo Line Switch
 Polished Nickel Finish
 Carrara Marble Base
 Oval Ascot White Fabric Shade

FINISH/SHADE OPTIONS:

- 2792B** Polished Nickel/Carrara Marble
Black Painted Opaque Parchment
w/ Silver Foil Lining
- 2257** Aged Brass/Travertine Stone
Fondine Fabric
- 2257B** Aged Brass/Travertine Stone
Black Painted Opaque Parchment
w/ Copper Foil Lining



W201



200

Marcel

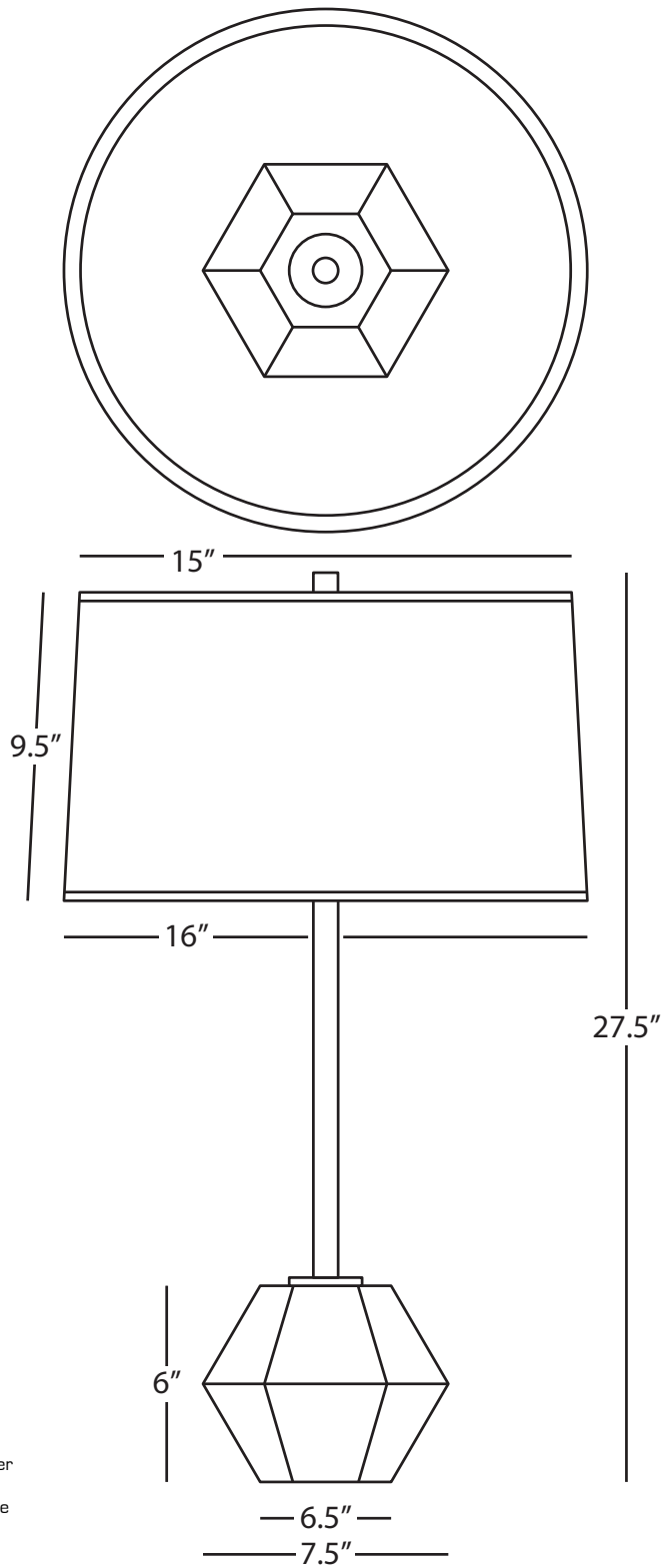

MARCEL

200

Table Lamp

1 - 150W Max.
Bulb Type: A
Switch: Full Range Dimmer
Modern Brass Finish
Matte Black Faceted Base
Oyster Linen Shade

FINISH OPTIONS:

201 Polished Nickel w/ Matte Black Base
W201 Polished Nickel w/ Matte White Base



S174



174

Margeaux

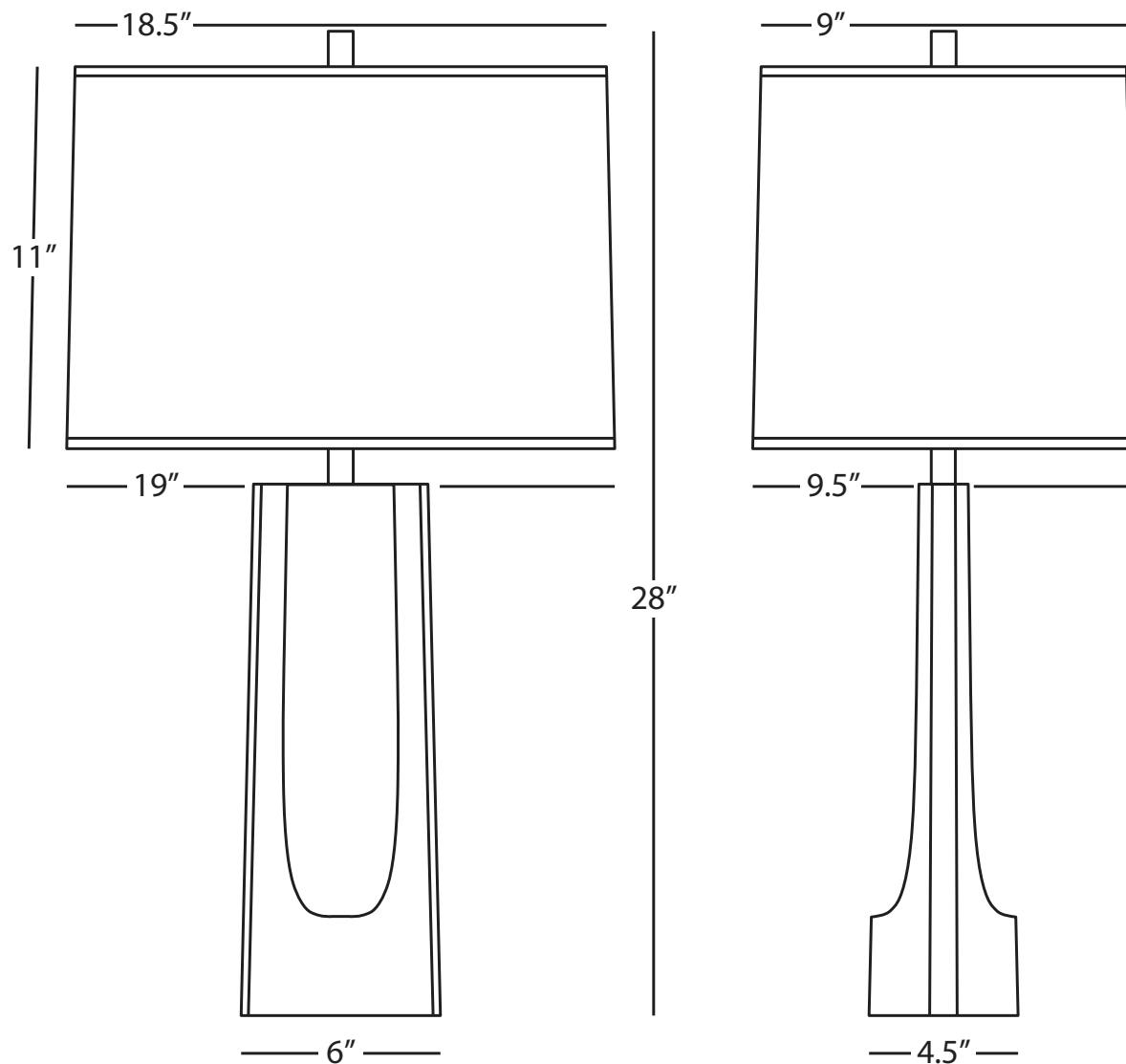

MARGEAUX

174

Table Lamp

1 - 100W Max.
Bulb Type: A
Switch: Full Range Dimmer
Modern Brass Finish w/
Brushed Modern Brass Accent
White Oval Organza Shade

FINISH OPTION:

S174 Polished and Brushed Nickel



CF960



979



G960



965



974



964

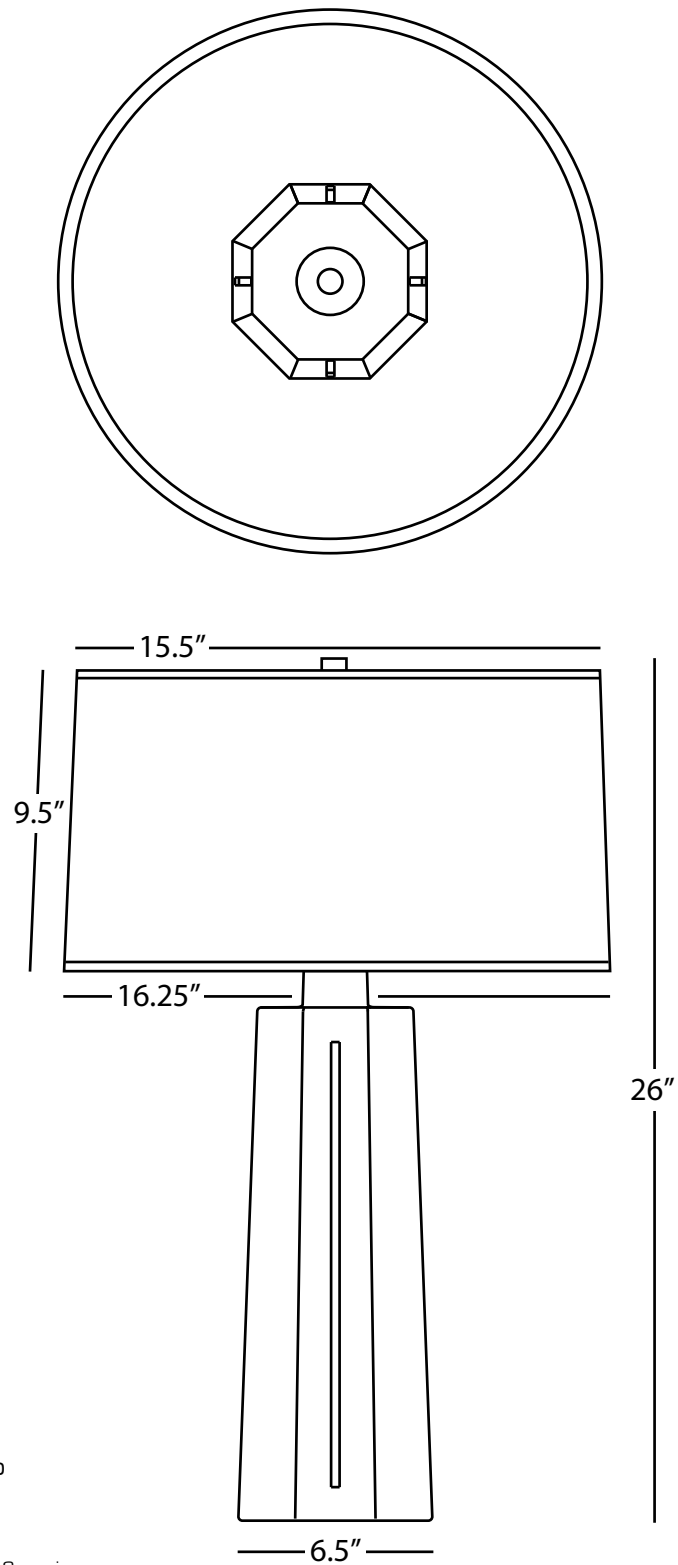

MASON

964
Table Lamp

1 - 150W Max.
Bulb Type: A
Switch: 3-Way
Peacock Glazed Ceramic
Polished Nickel Accents
Oyster Linen Shade

See Page 503 for Color Options available w/ Oyster Linen Shade

FINISH/SHADE OPTION:

G960 Polished Gold Glazed Ceramic w/
Polished Brass Accents
White Ceramic Parchment Shade w/ Gold Mylar Lining



3314

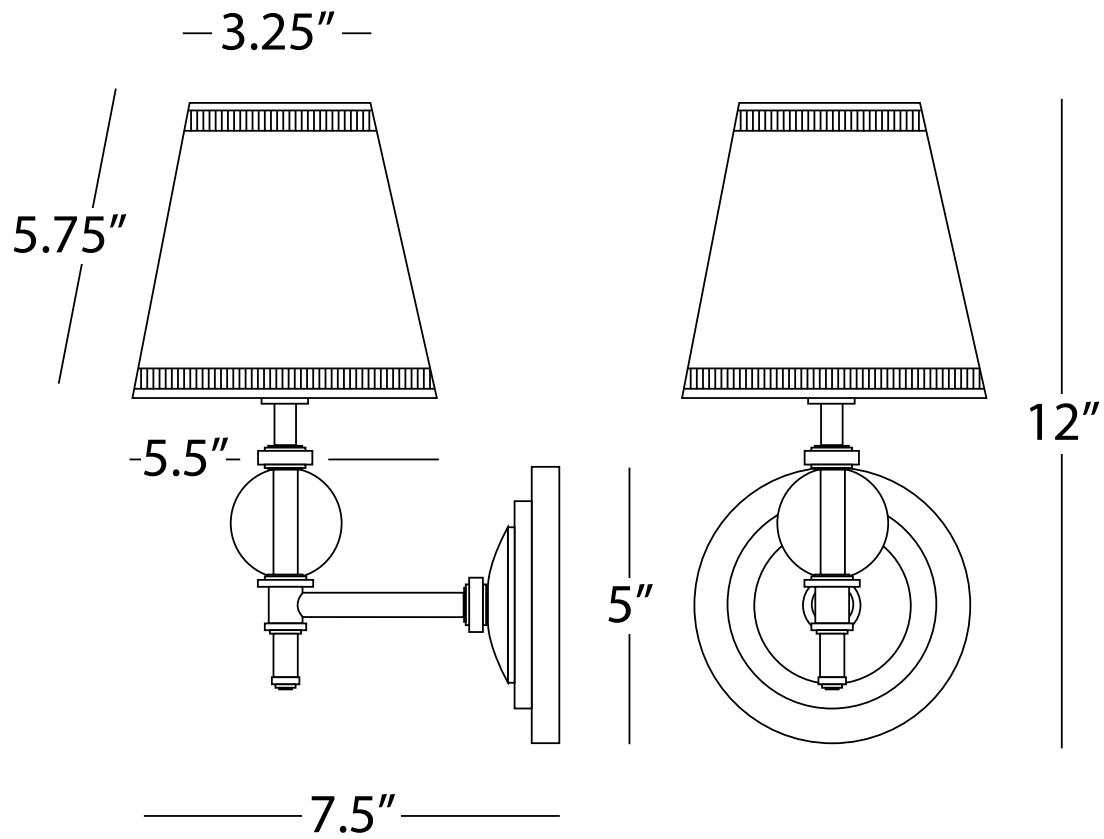

MUSE

3314

Wall Sconce

1 - 25W Max.
Bulb Type: B10, Candelabra
Direct Wire Only
Lead Crystal w/ Silver Plated Accents
White Mont Blanc Parchment
Shade w/ Grosgrain Trim



S195



195



S196

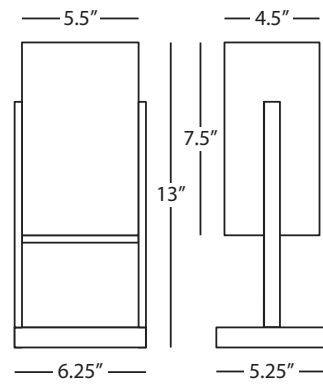

NIKOLE

195
Accent Lamp

1 - 60W Max.
Bulb Type: B, Candelabra Base
Switch: Hi-Lo Line Switch
Modern Brass Finish
White Marble Base
Frosted, White Acrylic Shade

FINISH OPTION:
S195 Polished Nickel

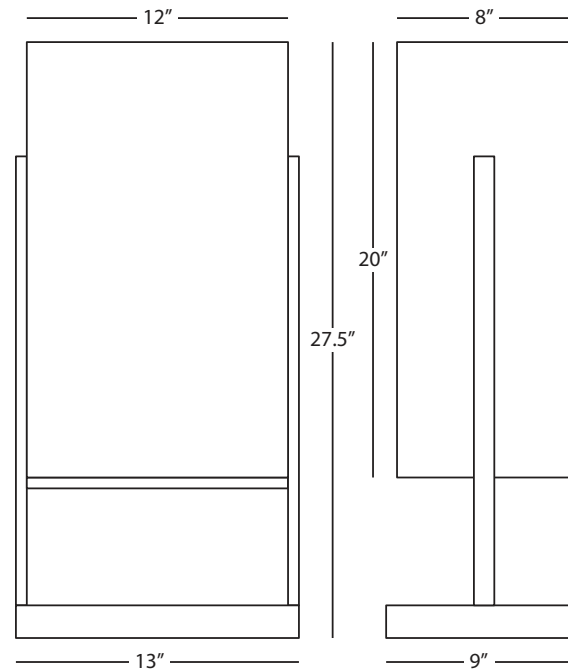

NIKOLE

S196
Table Lamp

1 - 150W Max.
Bulb Type: A
Switch: Hi-Lo Dimming
Polished Nickel Finish
White Marble Base
Frosted, White Acrylic Shade



233



S232

Nova



NOVA

233

Floor Lamp

1 - 100W Max.
Bulb Type: A
Switch: Full Range Dimmer Foot Switch
Modern Brass Finish
White Cased Glass Shade

FINISH OPTION:
S233 Polished Nickel

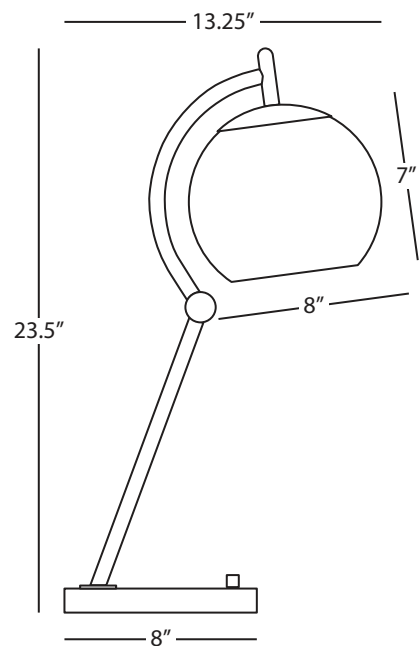

NOVA

S232

Table Lamp

1 - 100W Max.
Bulb Type: A
Switch: Full Range Dimmer
Polished Nickel Finish
White Cased Glass Shade
USB Port on Base

FINISH OPTION:
232 Modern Brass



406B



S405

Oculus

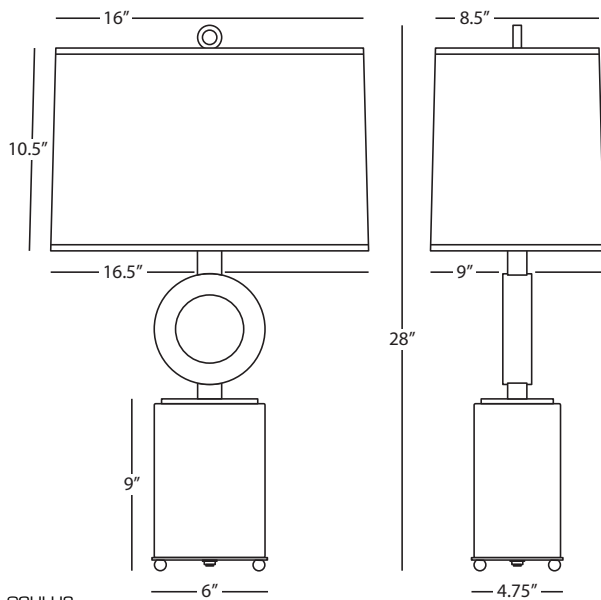

OCULUS

S405

Table Lamp

1 - 150W Max.
 Bulb Type: A
 Switch: Full Range Dimmer
 Antique Silver Finish w/
 White Marble Base
 Rectangular Oyster Linen Shade

FINISH/SHADE OPTIONS:

- 405** Warm Brass/Oyster Linen
- 405B** Warm Brass/Black Painted Opaque
Parchment Shade w/ White Lining
- S405B** Antique Silver/Black Painted Opaque
Parchment Shade w/ White Lining

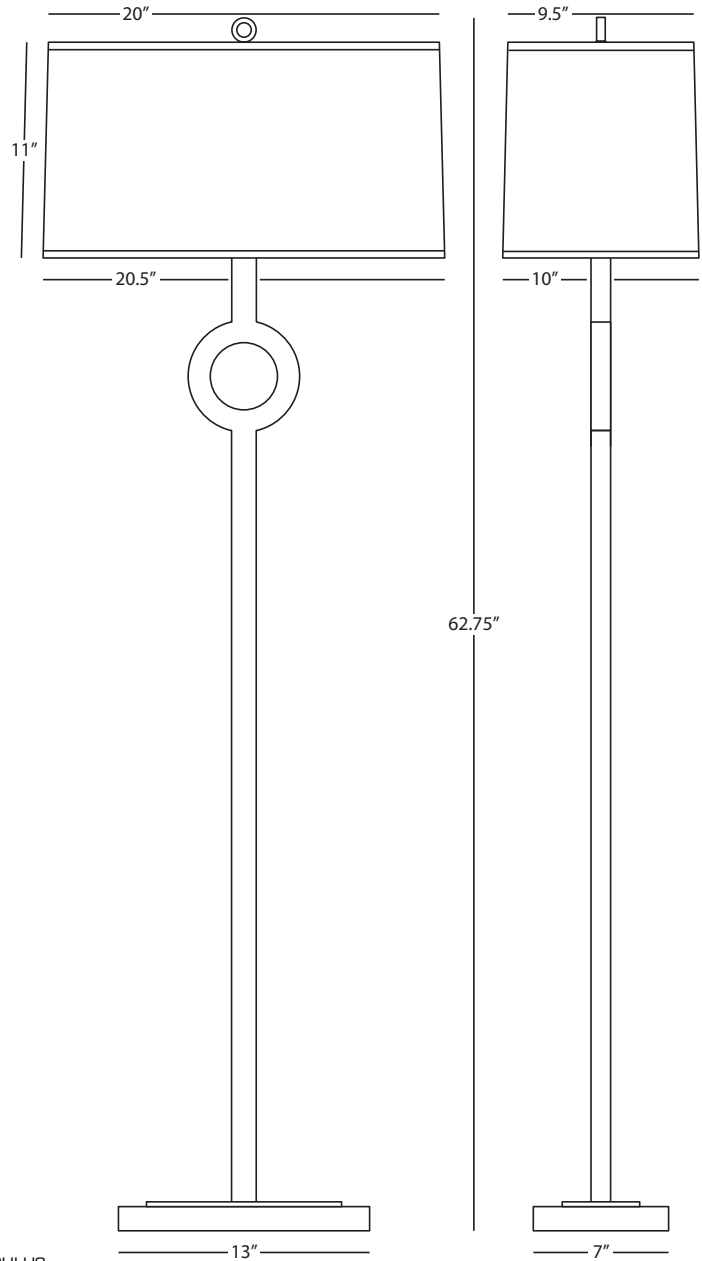

OCULUS

406B

Floor Lamp

1 - 150W Max.
 Bulb Type: A
 Switch: Full Range Dimmer
 Warm Brass Finish w/
 White Marble Base
 Rectangular Black Painted Opaque Parchment Shade
 w/ White Lining

FINISH/SHADE OPTIONS:

- 406** Warm Brass/Oyster Linen
- S406** Antique Silver/Oyster Linen
- S406B** Antique Silver/Black Painted Opaque
Parchment Shade w/ White Lining



829



828

OLIVER

829
Swing Arm Sconce

1 - 60W Max.
Bulb Type: B, Candelabra
Switch: On-Off Line Switch
24" Cord Cover/Direct Wire
Unfinished Mango Wood w/
Patina Nickel Accents
Open Weave Heather Linen Shade

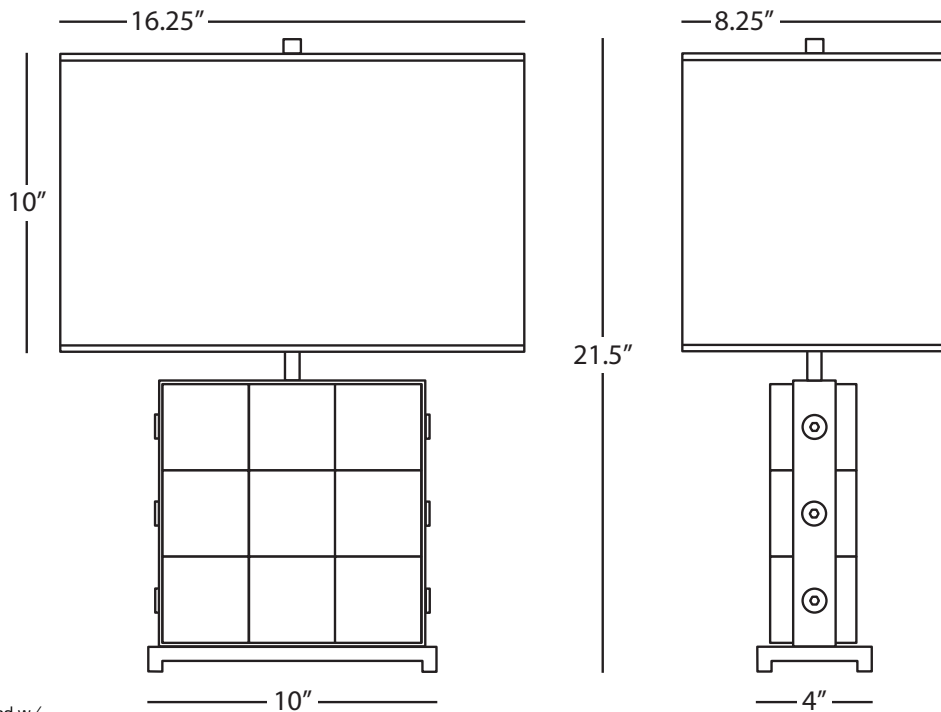
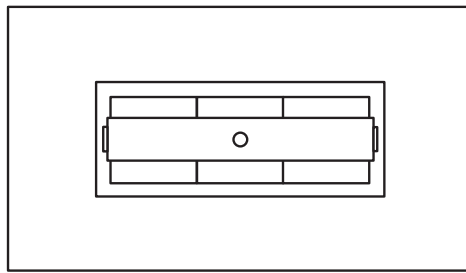
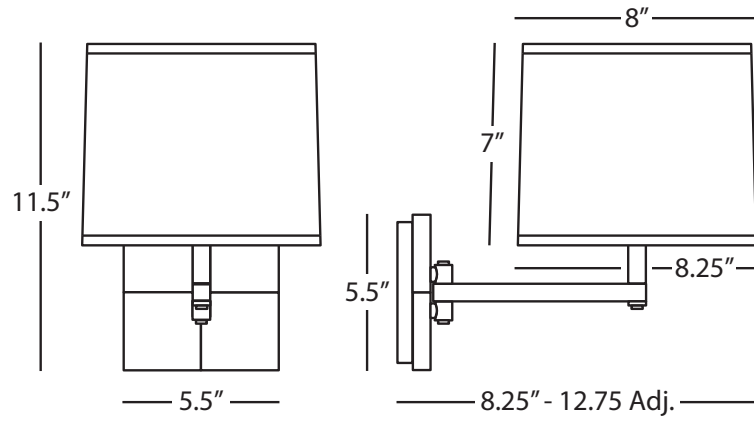

OLIVER

828
Table Lamp

1 - 150W Max.
Bulb Type: A
Switch: Hi-Lo Dimming
Unfinished Mango Wood w/
Patina Nickel Accents
Rectangular Open Weave Heather Linen Shade



BB999



PC999

MCR18



CI999



MCL17

BN989



ORION

BN989

Accent Lamp

1 - 60W Max.
 Bulb Type: B, Candelabra
 Switch: Hi-Lo Line Switch
 Bone Glazed Ceramic
 Oyster Linen Shade w/
 Self-Fabric Top Diffuser

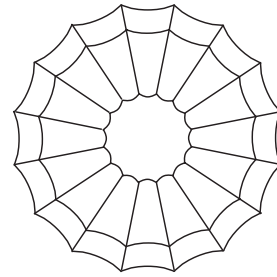

See Page 504 for Color Options

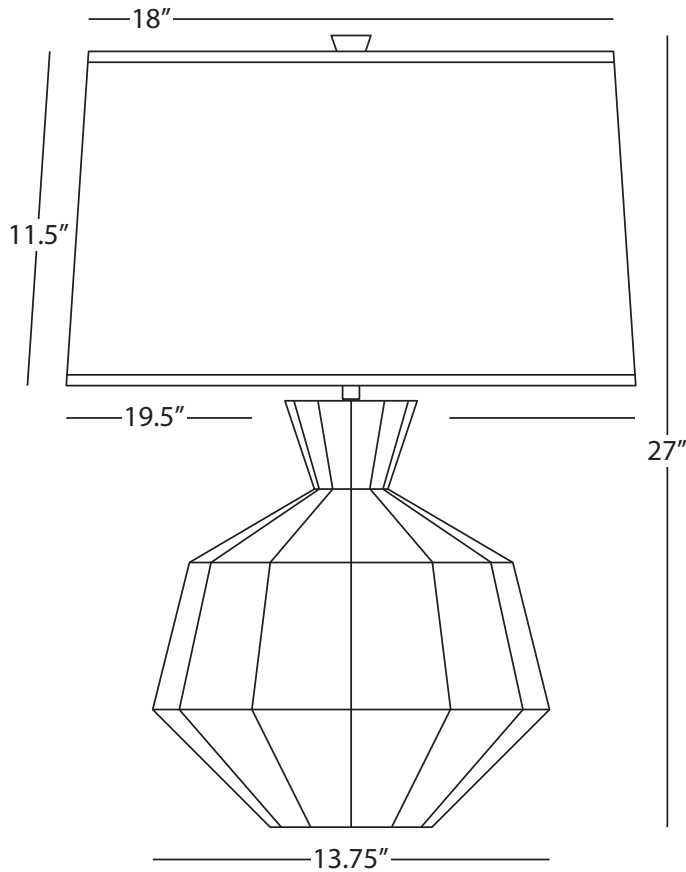
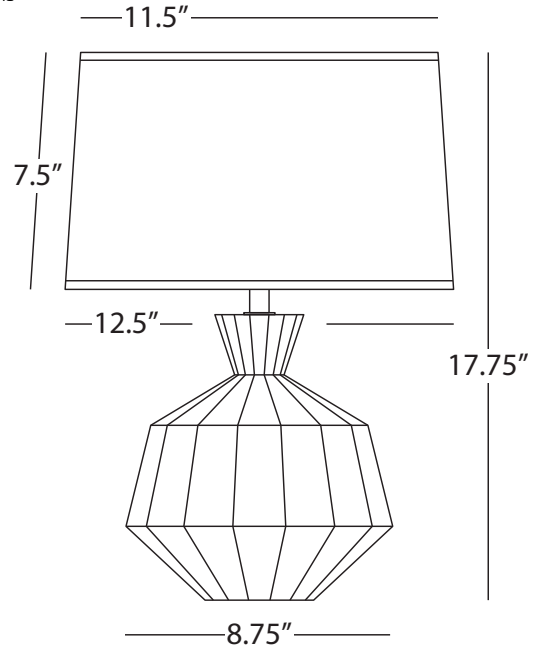
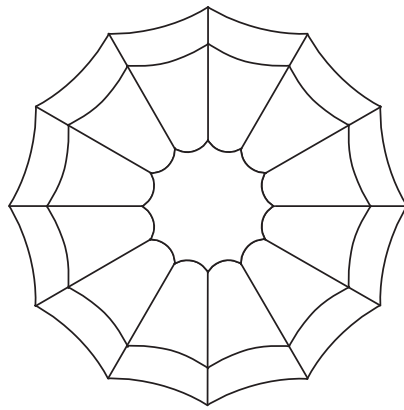

ORION

BB999

Table Lamp

1 - 150W Max.
 Bulb Type: A
 Switch: Hi-Lo Dimming
 Baby Blue Glazed Ceramic
 Oyster Linen Shade
 Self-Fabric Top Diffuser

See Page 504 for Color Options



LY44X



ST45X



ST44



MB45

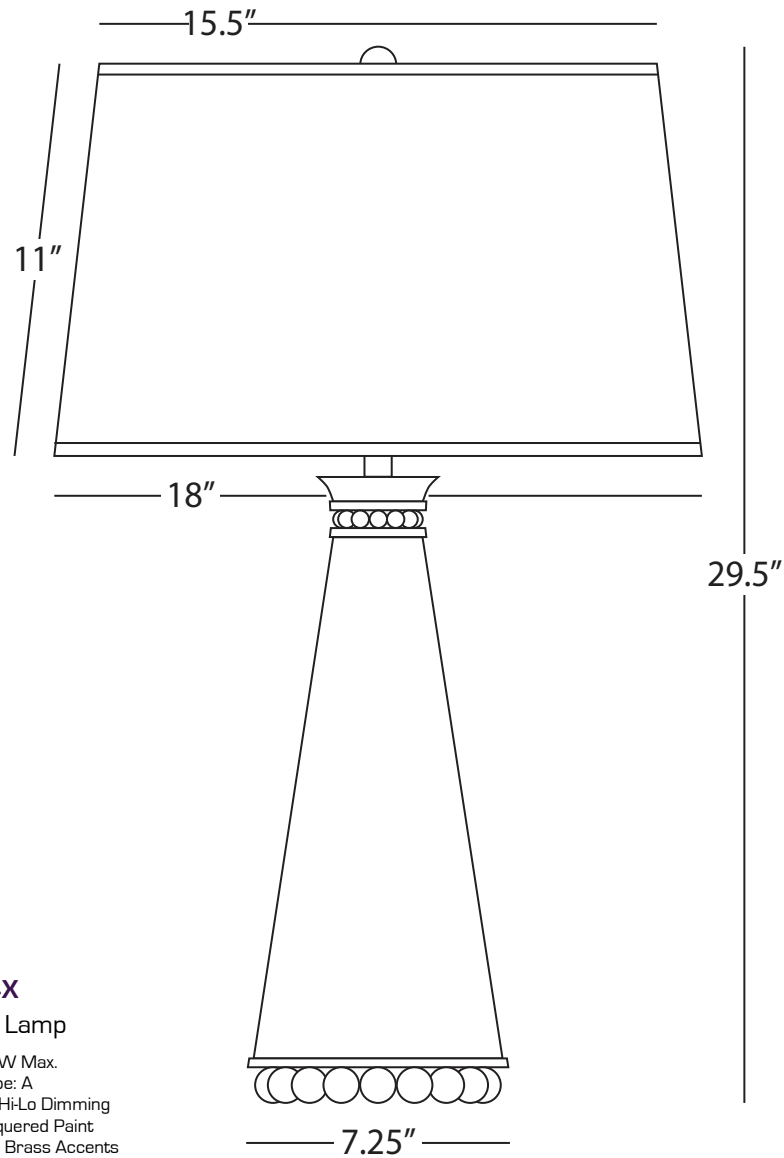

PEARL

LY44X

Table Lamp

1 - 150W Max.
 Bulb Type: A
 Switch: Hi-Lo Dimming
 Lily Lacquered Paint
 Modern Brass Accents
 Fondine Fabric Shade

FINISH/SHADE OPTIONS:

- | | |
|--------------|---|
| LY44 | Lily Lacquered Paint w/ Modern Brass Accents
Lily Painted Opaque Parchment w/ Gold Lining |
| LY45 | Lily Lacquered Paint w/ Polished Nickel Accents
Lily Painted Opaque Parchment w/ Silver Lining |
| LY45X | Lily Lacquered Paint w/ Polished Nickel Accents
Fondine Fabric Shade |
| MB44 | Midnight Blue Lacquered Paint w/ Modern Brass Accents
Midnight Blue Painted Opaque Parchment w/ Gold Lining |
| MB44X | Midnight Blue Lacquered Paint w/ Modern Brass Accents
Fondine Fabric Shade |
| MB45 | Midnight Blue Lacquered Paint w/ Polished Nickel Accents
Midnight Blue Painted Opaque Parchment w/ Silver Lining |
| MB45X | Midnight Blue Lacquered Paint w/ Polished Nickel Accents
Fondine Fabric Shade |
| ST44 | Smoky Taupe Lacquered Paint w/ Modern Brass Accents
Smoky Taupe Painted Opaque Parchment w/ Gold Lining |
| ST44X | Smoky Taupe Lacquered Paint w/ Modern Brass Accents
Fondine Fabric Shade |
| ST45 | Smoky Taupe Lacquered Paint w/ Polished Nickel Accents
Smoky Taupe Painted Opaque Parchment w/ Silver Lining |
| ST45X | Smoky Taupe Lacquered Paint w/ Polished Nickel Accents
Fondine Fabric Shade |



595



596

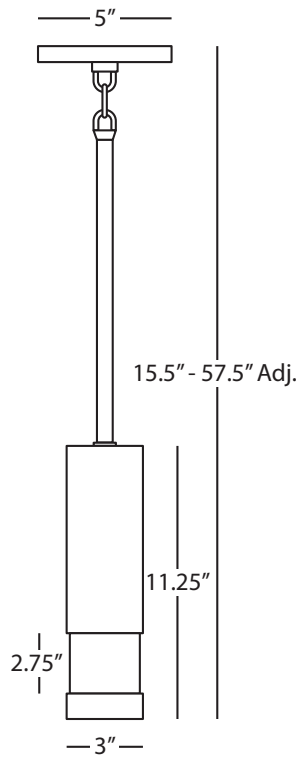

PEEK

595

Pendant

1 - 60W Max.
 Bulb Type: B, Medium Base
 Direct Wire
 Polished Aluminum Finish
 Cased White Glass Shade
 Susp. Hardware: 1 pc. 5/8" x 6" & 3 pcs.
 5/8" x 12" Extensions

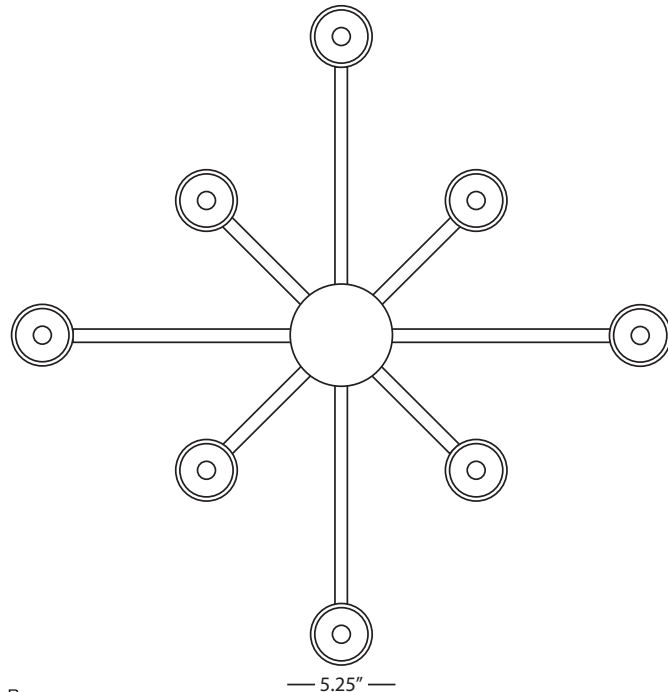

PEEK

596

Chandelier

16 - 60W Max.
 Bulb Type: B, Candelabra Base
 Direct Wire
 Polished Aluminum Finish
 Cased White Glass Shades
 Susp. Hardware: 1 pc. 5/8" x 6" &
 3 pcs. 5/8" x 12" Extensions

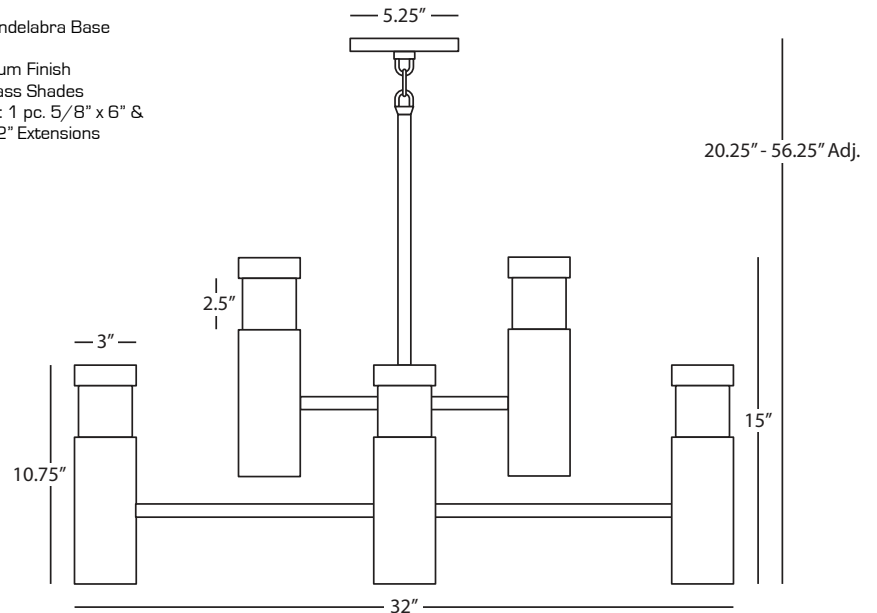



A808



F808



O808



N808



T808

Penelope

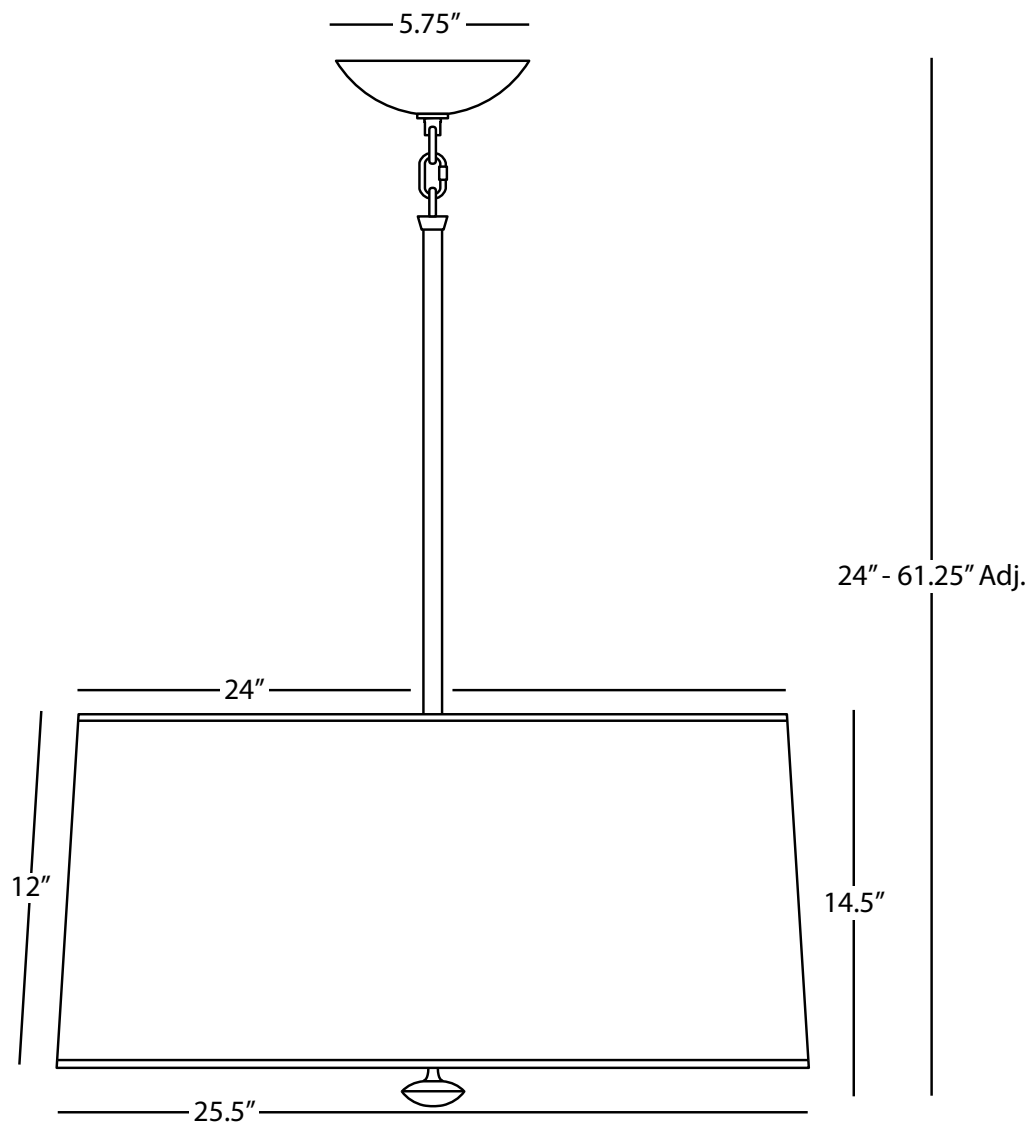

PENELOPE

N808

Pendant

3 - 100W Max.
Bulb Type: A
Direct Wire Only
Polished Nickel Finish
Lead Crystal Finial
Navy Ceramic Parchment Shade w/ Silver Mylar Lining
13.25" Dia. Polished Nickel Finished Metal Diffuser Included
Susp. Hardware: 3 pcs. 5/8" x 12" & 1 pc. 5/8" x 6" Extensions

SHADE OPTIONS:

A808 Ascot White Fabric Shade
B808 Black Ceramic Parchment w/ Silver Mylar Lining
F808 Fuchsia Ceramic Parchment w/ Silver Mylar Lining
O808 Orange Ceramic Parchment w/ Silver Mylar Lining
R808 Red Ceramic Parchment w/ Silver Mylar Lining
S808 Silver Mylar w/ White Ceramic Parchment Lining
T808 Taupe Ceramic Parchment w/ Silver Mylar Lining
W808 White Ceramic Parchment w/ Silver Mylar Lining



G808

Penelope

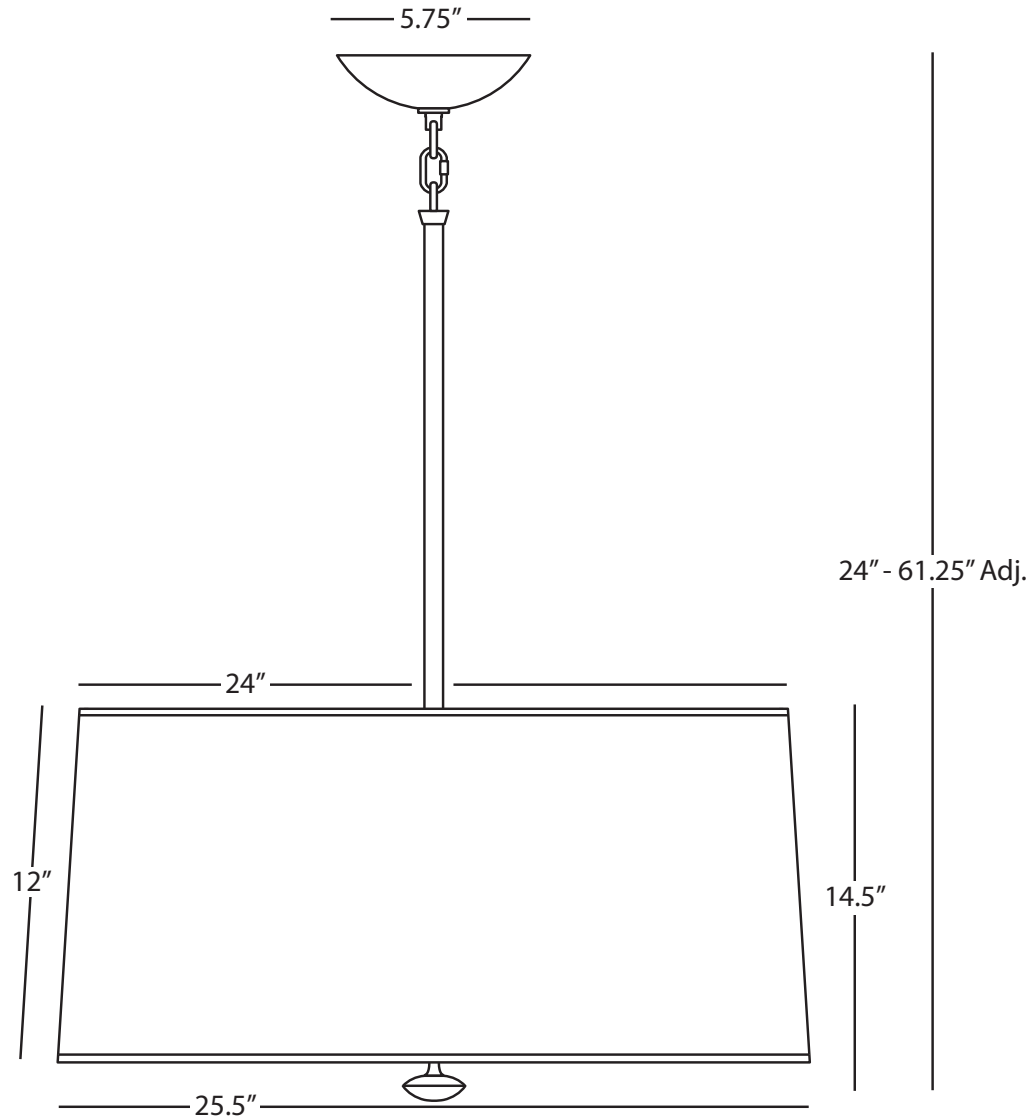

PENELOPE

G808 Pendant

3 - 100W Max.
Bulb Type: A
Direct Wire Only
Polished Brass Finish
Lead Crystal Finial
White Ceramic Parchment Shade
w/ Gold Mylar Lining
13.25" Polished Brass Finished
Metal Diffuser Included
Susp. Hardware: 3 pcs. 5/8" x 12"
& 1 pc. 5/8" x 6" Extensions

Pierce



Pierce

[Click photo above to watch Pierce Table Lamp video](#)

Sleek and contemporary, Pierce's perforated surfaces allow pinpoint points of light to shine through for an enchanting effect. We've added brilliant pops of color to this collection for October 2020 by introducing canary yellow, pumpkin, egg blue, and ruby red to the Pierce table lamp and new task lamp.



CY780



EB780



RR780



PM780



PB780

Pierce

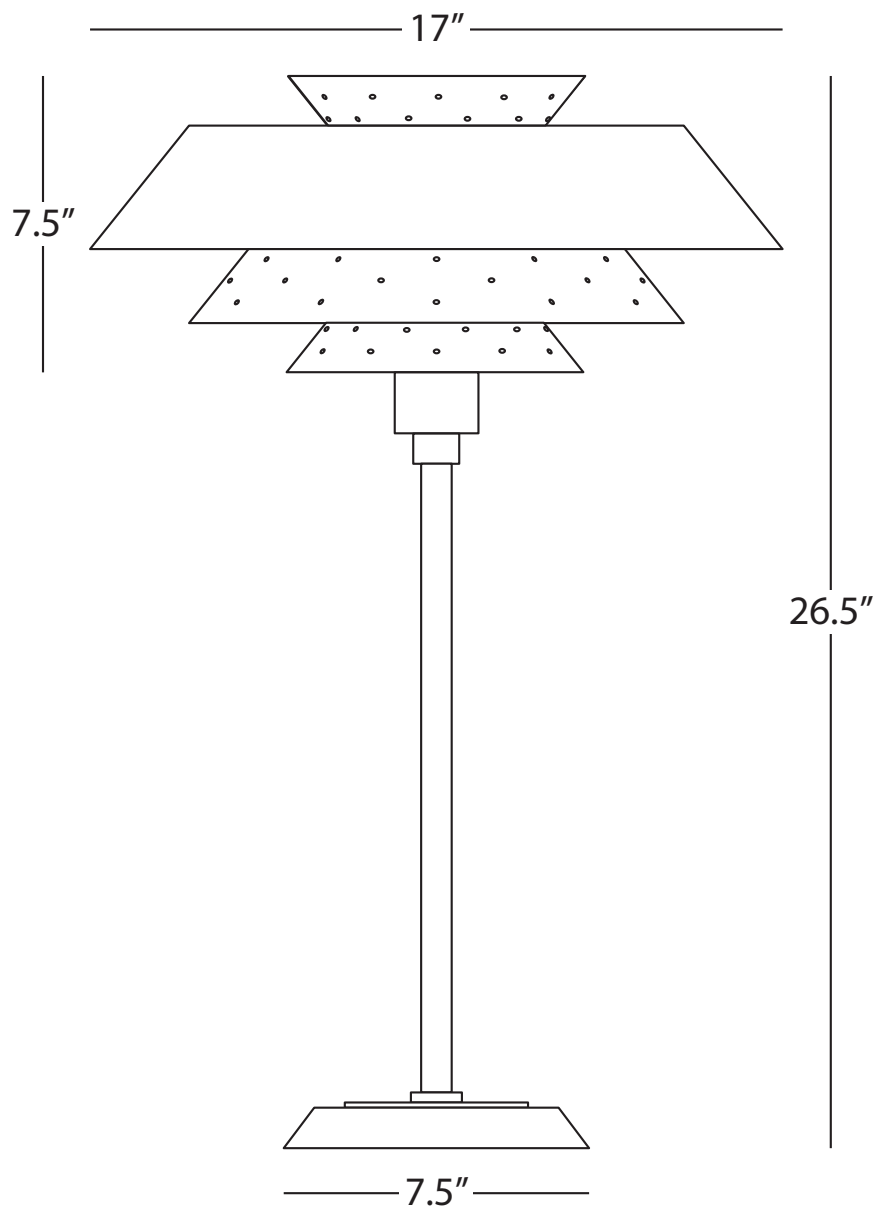

PIERCE

S980

Table Lamp

1 - 150W Max.

Bulb Type: A

Switch: Full Range Dimmer Line Switch

Antique Silver Finish

Perforated Metal Shade with White Interior

FINISH OPTIONS:

CY780 Canary Yellow Gloss

EB780 Egg Blue Gloss

PB780 Piano Black Gloss

PM780 Pumpkin Gloss

Pierce



Pierce

[Click photo above to watch Pierce Task Table Lamp video](#)

Sleek and contemporary, Pierce's perforated surfaces allow pinpoint points of light to shine through for an enchanting effect. We've added brilliant pops of color to this collection for October 2020 by introducing canary yellow, pumpkin, egg blue, and ruby red to the Pierce table lamp and new task lamp.



CY988



RR988



EB988



PM988



PB988

Pierce

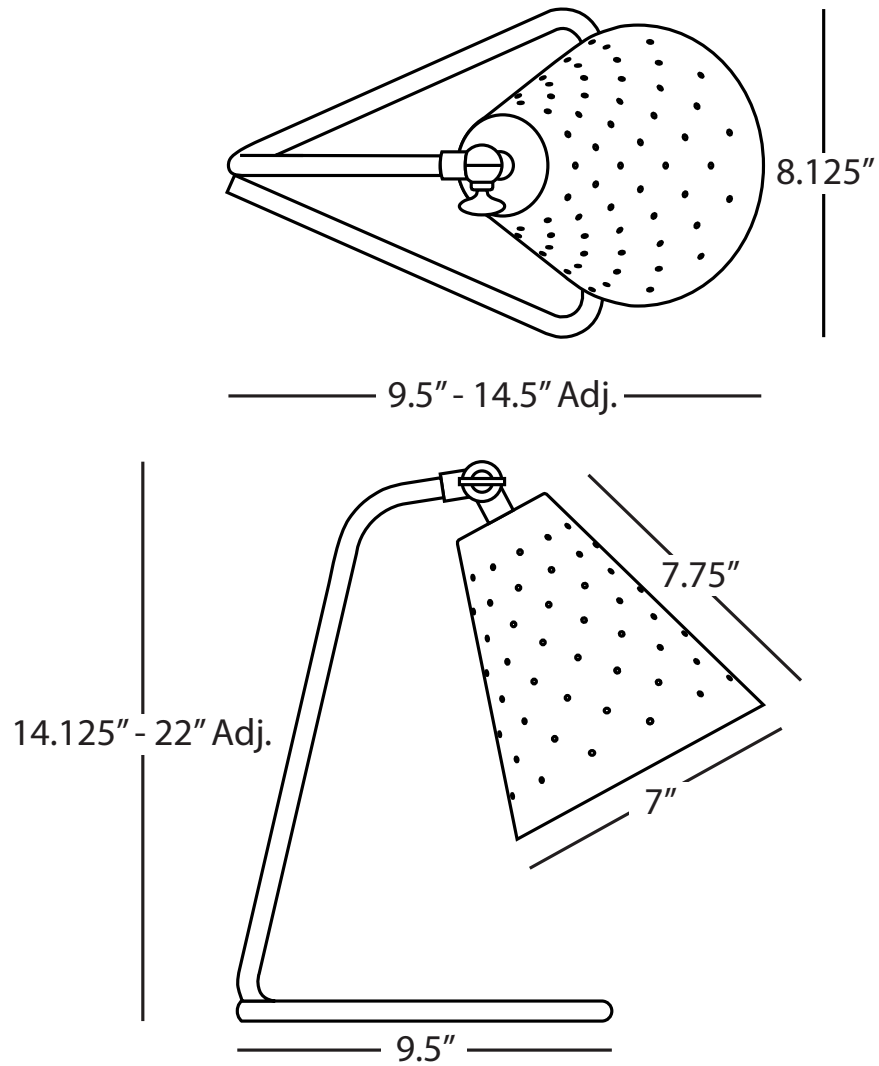

PIERCE

CY988

Task Table Lamp

1 - 60W Max.
Bulb Type: A
Switch: Full Range Dimmer Line Switch
Canary Yellow Gloss Finish
Perforated Metal Shade w/ White Interior

FINISH OPTIONS:

988	Modern Brass
EB988	Egg Blue Gloss
PB988	Piano Black Gloss
PM988	Pumpkin Gloss
RR988	Ruby Red Gloss
S988	Antique Silver



984



S981



982

Pierce

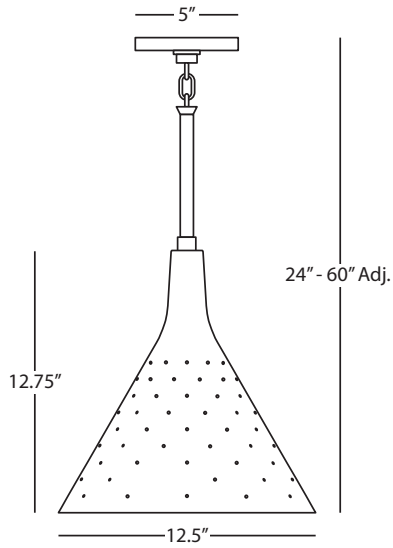

PIERCE

984 Pendant

1 - 100W Max.
Bulb Type: A
Direct Wire
Modern Brass Finish
Perforated Metal Shade w/ White Interior
Susp. Hardware: 3 pcs. 5/8" x 12"
& 1 pc. 5/8" x 6" Extensions

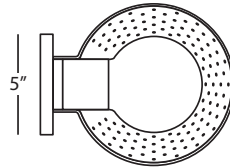

PIERCE

982 Wall Sconce

1 - 60W Max.
Bulb Type: A
Direct Wire Only
Modern Brass Finish
Perforated Metal Shade w/
White Interior

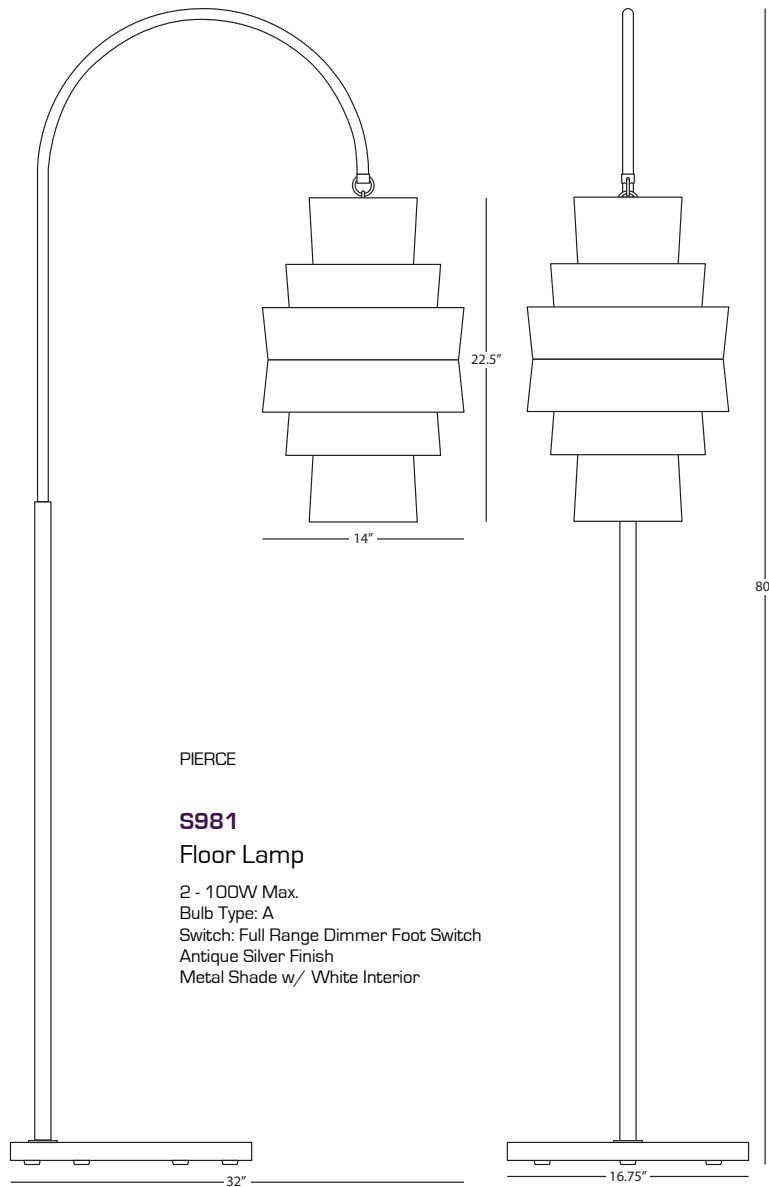
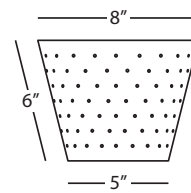
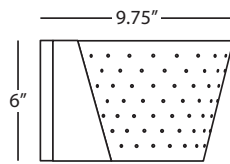

PIERCE

S981 Floor Lamp

2 - 100W Max.
Bulb Type: A
Switch: Full Range Dimmer Foot Switch
Antique Silver Finish
Metal Shade w/ White Interior

Pierce



Pierce

[Click photo above to watch Pierce Pendant Video](#)

Sleek and contemporary, Pierce's perforated surfaces allow pinpoints of light to shine through for an enchanting effect.



CY983



PM983



RR983



PB983



EB983

Pierce

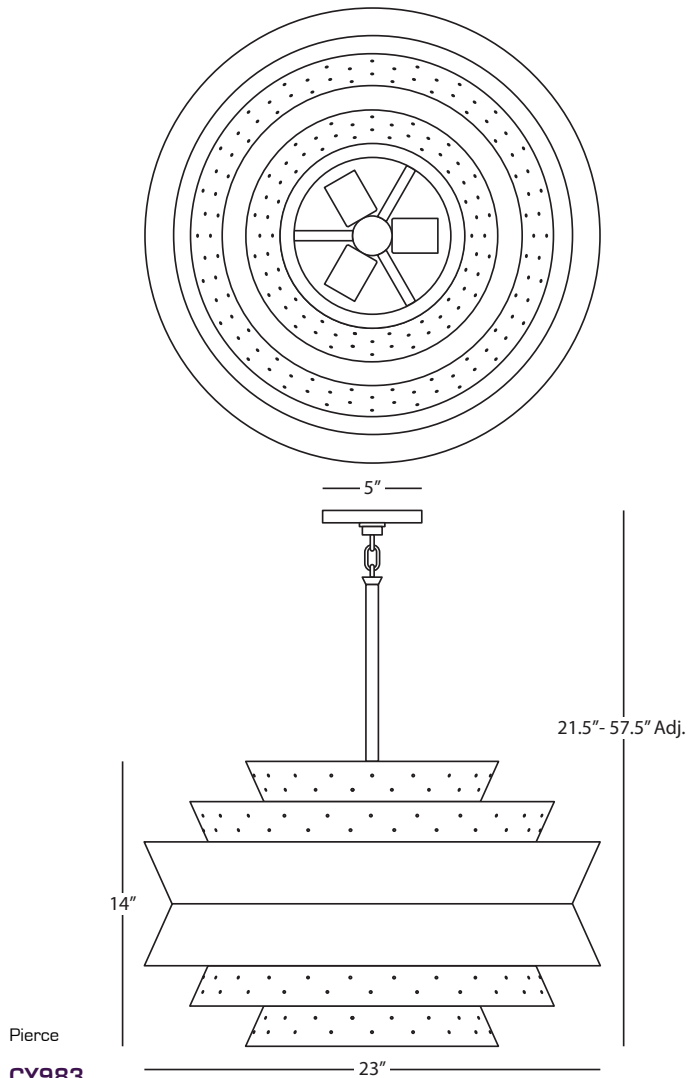

Pierce

CY983

Large Pendant

3 - 60W Max.
Bulb Type: B
Direct Wire
Canary Yellow Gloss Finish
Perforated Metal Shade with White Interior
Susp. Hardware: 3 pcs. 5/8" X 12"
& 1 pc. 5/8" X 6" Extension Rods

FINISH OPTIONS:

983	Modern Brass
EB983	Egg Blue Gloss
PB983	Piano Black Gloss
PM983	Pumpkin Gloss
RR983	Ruby Red Gloss



Pierce

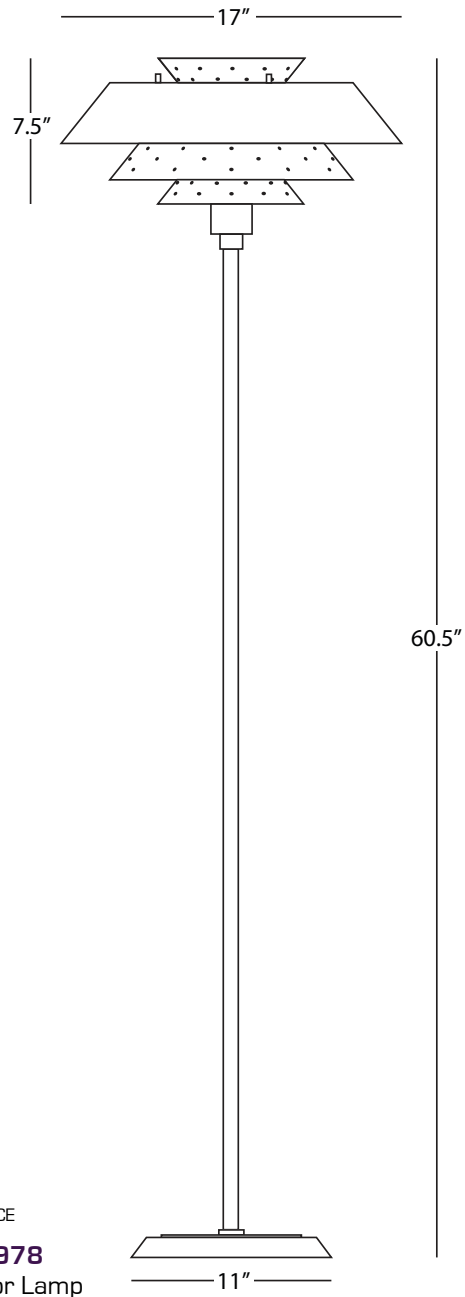

PIERCE

RR978
Floor Lamp

1 - 150W Max.
Bulb Type: A
Switch: Full Range Dimmer Line Switch
Ruby Red Gloss Finish
Perforated Metal Shade

FINISH OPTIONS:

- PB978** Piano Black Gloss
- PM978** Pumpkin Gloss
- CY978** Canary Gloss
- EB978** Egg Blue Gloss



CI996



PC996



TE994



SU994



ST994

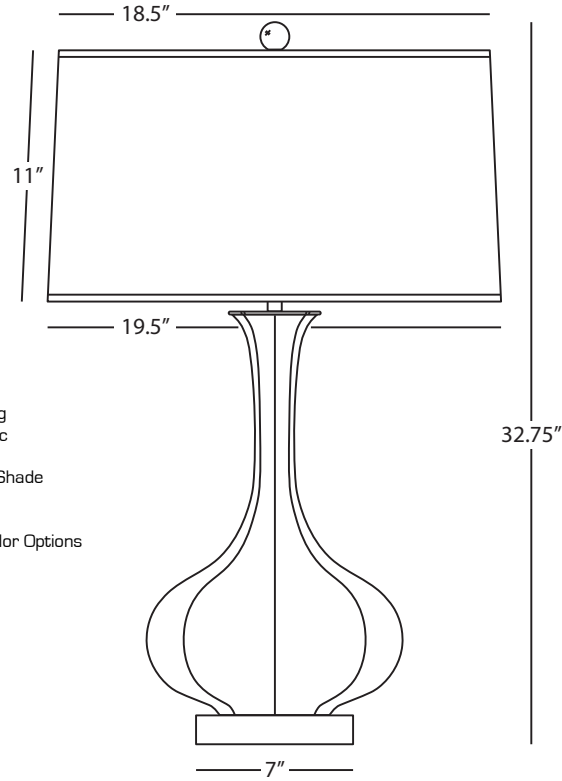
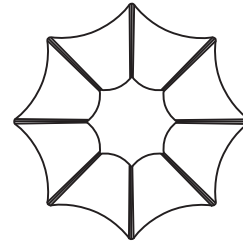

PIKE

CI996

Table Lamp

1 - 150W Max.
 Bulb Type: A
 Switch: Hi-Lo Dimming
 Citron Glazed Ceramic
 Lucite Base
 Pearl Dupioni Fabric Shade

See Page 505 for Color Options

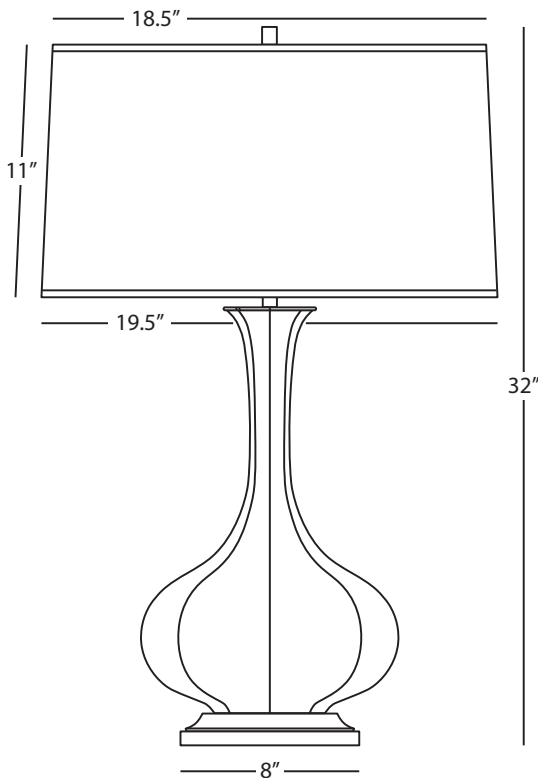
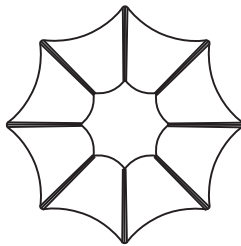

PIKE

ST994

Table Lamp

1 - 150W Max.
 Bulb Type: A
 Switch: Hi-Lo Dimming
 Smoky Taupe Glazed Ceramic
 Aged Brass Accents
 Pearl Dupioni Fabric Shade

See Page 505 for Color Options



1445



1446



1444



1447

Ranger

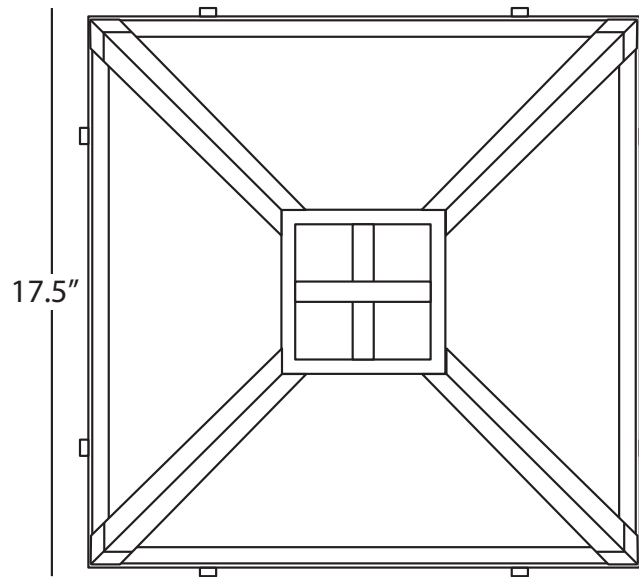

— 5.25" —

RANGER

1444

Pendant

3 - 60W Max.

Bulb Type: A

Direct Wire

Matte Black Painted Finish w/

Modern Brass Accents

Square, Printed White Glass Diffuser

Susp. Hardware: 3 Ft. Chain

FINISH OPTIONS:

1445 Glossy White w/ Modern Brass Accents

1446 Matte Black w/ Polished Nickel Accents

1447 Glossy White w/ Polished Nickel Accents

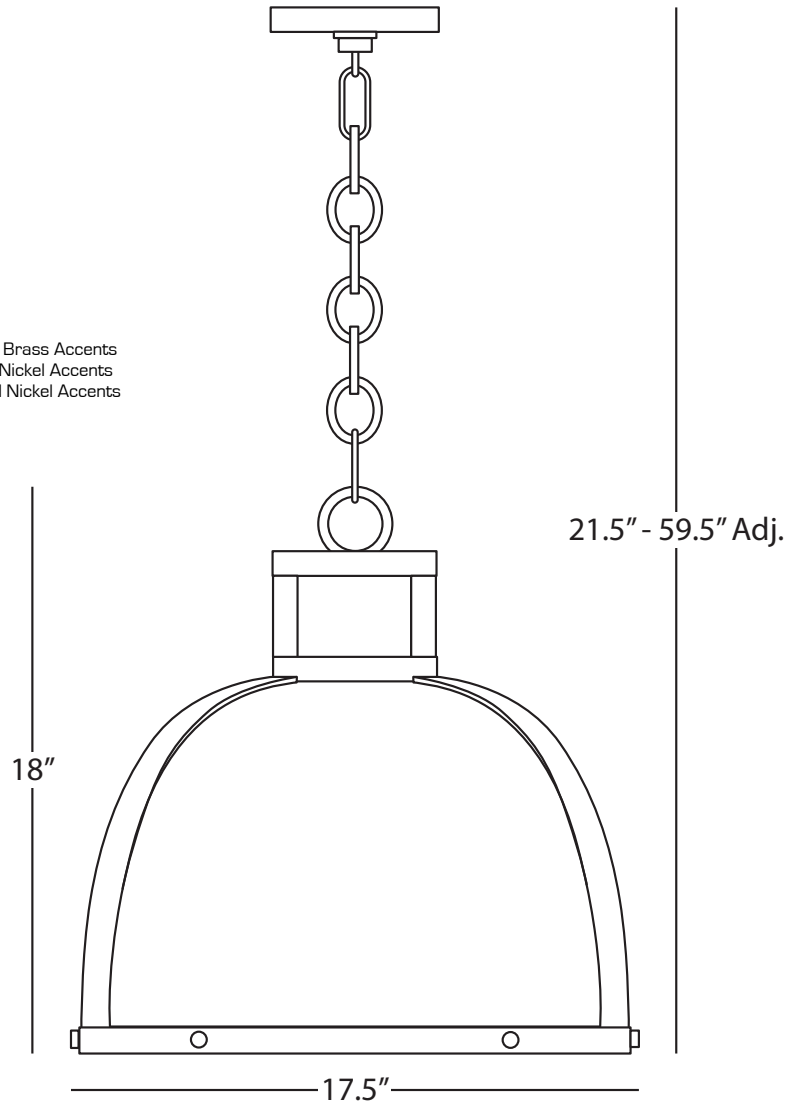



480



483



483X

Raquel

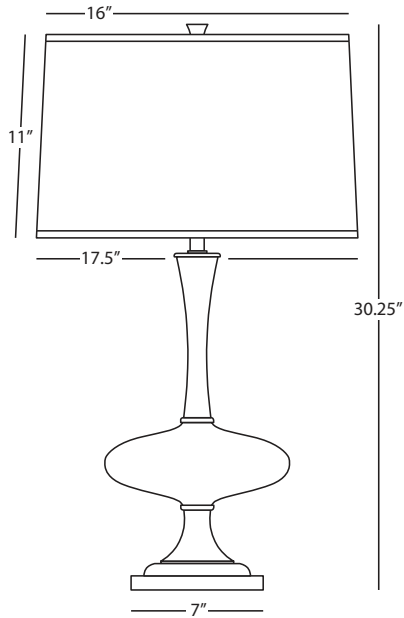
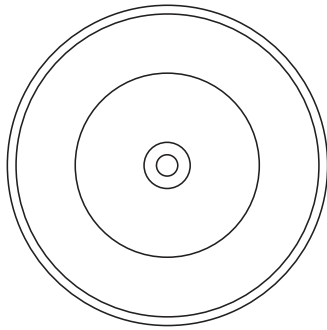

RAQUEL

483X Oval Table Lamp

1 - 150W Max.
Bulb Type: A
Switch: Hi-Lo Dimming
White Glass w/ Modern Brass
and Carrara Marble Accents
Oval Pearl Dupioni Fabric Shade

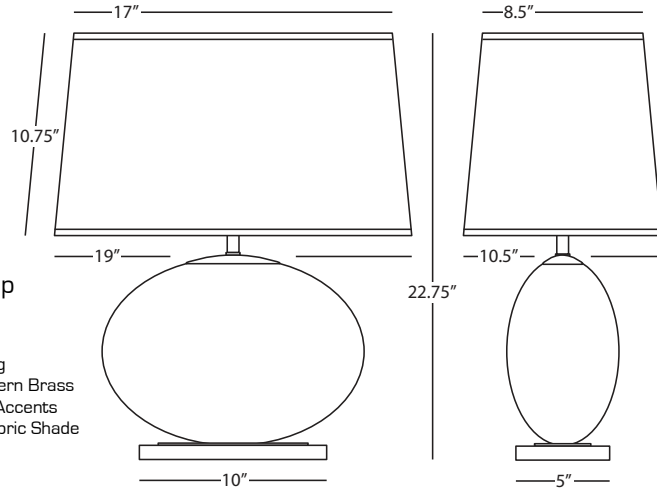

RAQUEL

480 Table Lamp

1 - 150W Max.
Bulb Type: A
Switch: Hi-Lo Dimming
White Glass w/ Modern Brass
and Carrara Marble Accents
Pearl Dupioni Fabric Shade

RAQUEL

483 Oval Table Lamp

1 - 150W Max.
Bulb Type: A
Switch: Hi-Lo Dimming
White Glass w/ Modern Brass
and Carrara Marble Accents
Tall Oval Pearl Dupioni Fabric Shade

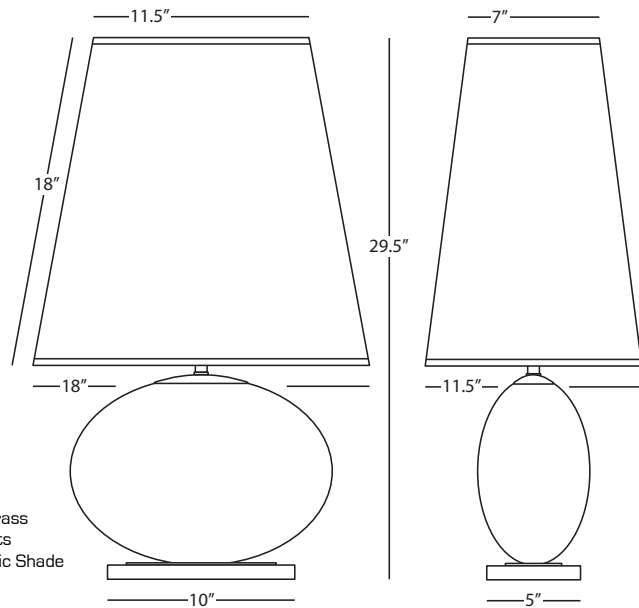



1833



1802



Z1815



1824

Real Simple

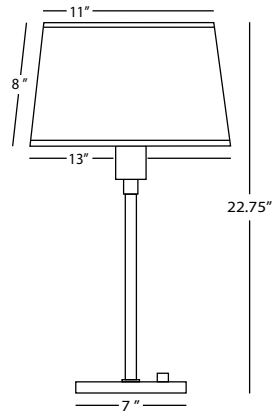

REAL SIMPLE

1802 Club Table Lamp

1 - 100W Max.
Bulb Type: A
Switch: Hi-Lo Base Switch
Stardust White Powder Coat Finish
White Mont Blanc Parchment Shade
w/ Self-Fabric Top Diffuser

FINISH/SHADE OPTIONS:

- Z1812** Dark Bronze
Snowflake Fabric
- 1822** Gunmetal
Snowflake Fabric
- 1832** Matte Black
Snowflake Fabric

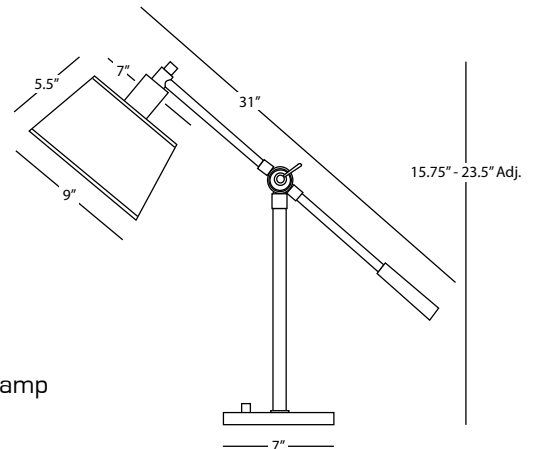

REAL SIMPLE

1833 Boom Table Lamp

1 - 100W Max.
Bulb Type: A
Switch: Hi-Lo Base Switch
Matte Black Powder Coat Finish
Snowflake Fabric Shade w/ Self-Fabric Top Diffuser

FINISH/SHADE OPTIONS:

- 1803** Stardust White
White Mont Blanc Parchment
- Z1813** Dark Bronze
Snowflake Fabric
- 1823** Gunmetal
Snowflake Fabric

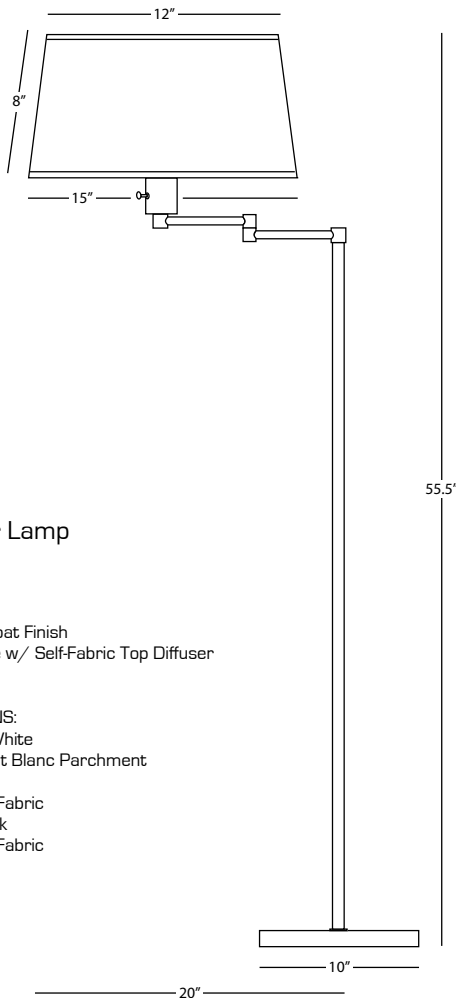

REAL SIMPLE

Z1815 Swing Arm Floor Lamp

1 - 150W Max.
Bulb Type: A
Switch: 3-Way
Dark Bronze Powder Coat Finish
Snowflake Fabric Shade w/ Self-Fabric Top Diffuser

FINISH/SHADE OPTIONS:

- 1805** Stardust White
White Mont Blanc Parchment
- 1825** Gunmetal
Snowflake Fabric
- 1835** Matte Black
Snowflake Fabric

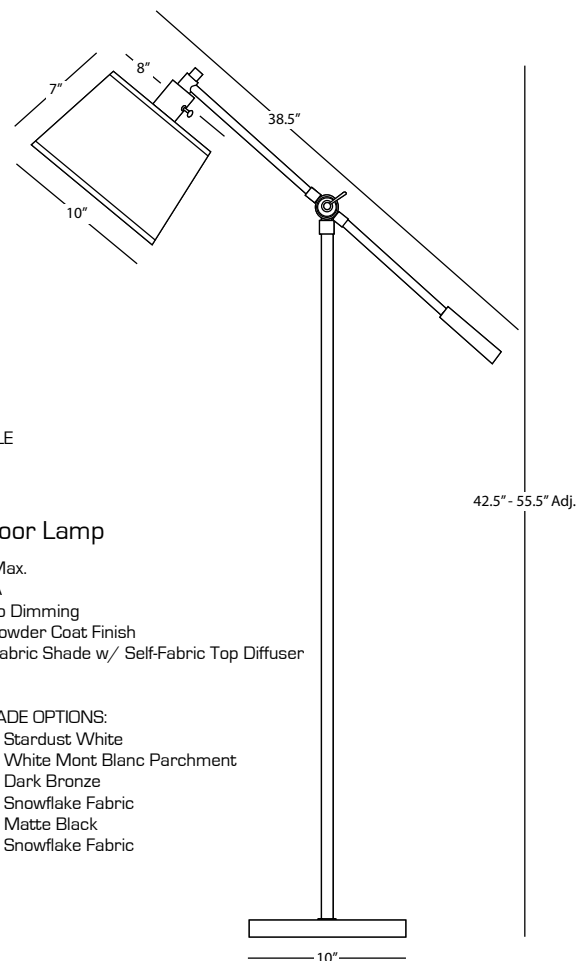

REAL SIMPLE

1824 Boom Floor Lamp

1 - 100W Max.
Bulb Type: A
Switch: Hi-Lo Dimming
Gunmetal Powder Coat Finish
Snowflake Fabric Shade w/ Self-Fabric Top Diffuser

FINISH/SHADE OPTIONS:

- 1804** Stardust White
White Mont Blanc Parchment
- Z1814** Dark Bronze
Snowflake Fabric
- 1834** Matte Black
Snowflake Fabric



1827



1806



Z1819



1839

REAL SIMPLE

1827 4-Light Chandelier

4 - 60W Max.
Bulb Type: B10, Candelabra
Direct Wire Only
Gunmetal Powder Coat Finish
Snowflake Fabric Shades w/ Self-Fabric Bottom Diffusers
Susp. Hardware: 3 pcs. 5/8" x 12" & 1 pc. 5/8" x 6" Extensions

FINISH/SHADE OPTIONS:

- 1807** Stardust White
White Mont Blanc Parchment
- Z1817** Dark Bronze
Snowflake Fabric
- 1837** Matte Black
Snowflake Fabric

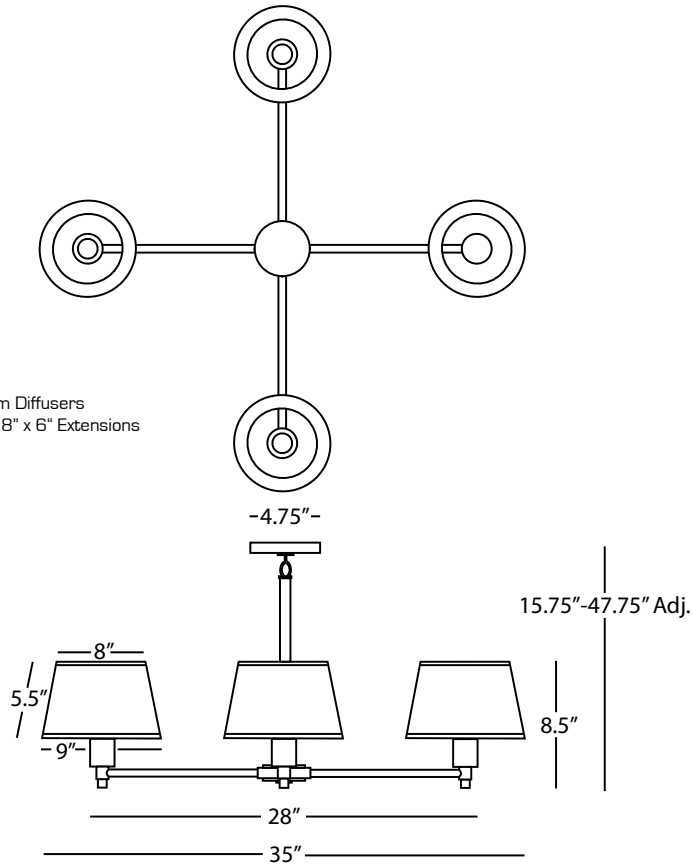

REAL SIMPLE

1806 Swing Arm Sconce

1 - 60W Max.
Bulb Type: A
Switch: Hi-Lo Dimming
24" Cord Cover/Direct Wire
Stardust White Powder Coat Finish
White Mont Blanc Parchment Shade
w/ Self-Fabric Bottom Diffuser

FINISH/SHADE OPTIONS:

- Z1816** Dark Bronze
Snowflake Fabric
- 1826** Gunmetal
Snowflake Fabric
- 1836** Matte Black
Snowflake Fabric

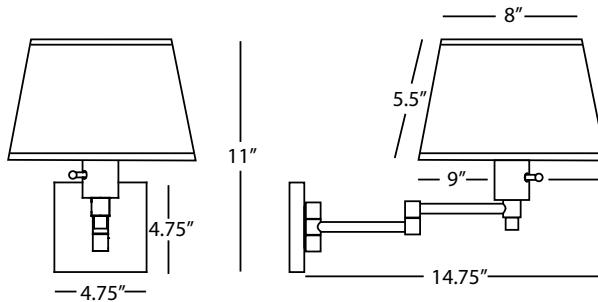

REAL SIMPLE

Z1819 Wall Mounted Boom Lamp

1 - 60W Max.
Bulb Type: A
Switch: Hi-Lo Dimming
24" Cord Cover/Direct Wire
Dark Bronze Powder Coat Finish
Snowflake Fabric Shade w/ Self-Fabric Bottom Diffuser

FINISH/SHADE OPTIONS:

- 1809** Stardust White
White Mont Blanc Parchment
- 1829** Gunmetal
Snowflake Fabric
- 1839** Matte Black
Snowflake Fabric

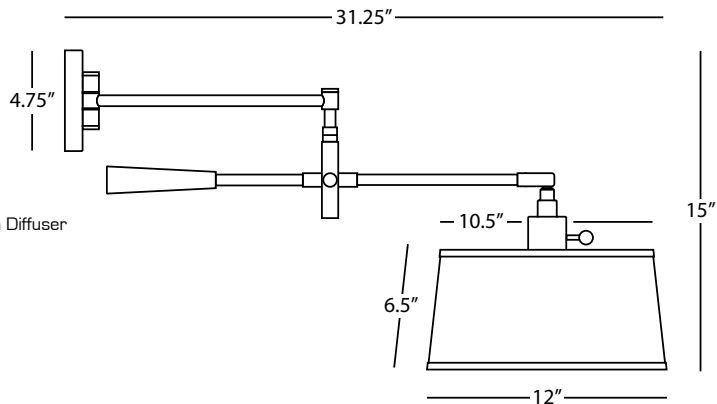



B1316



C1317



S1314



Z1314

RODERICK

B1316

10" Dia. Flush Mount

1 - 60W Max.
Bulb Type: B10, Candelabra
Direct Wire Only
Antique Silver Finish
White Frosted Glass Shade

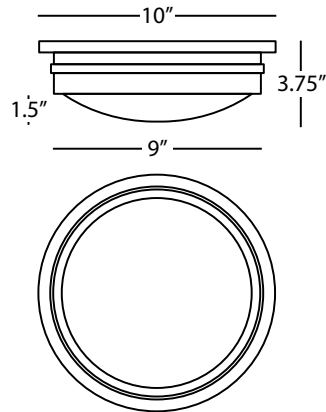

RODERICK

Z1314

13.5" Dia. Flush Mount

2 - 60W Max.
Bulb Type: B11 Torpedo
Direct Wire Only
Deep Patina Bronze
White Frosted Glass Shade

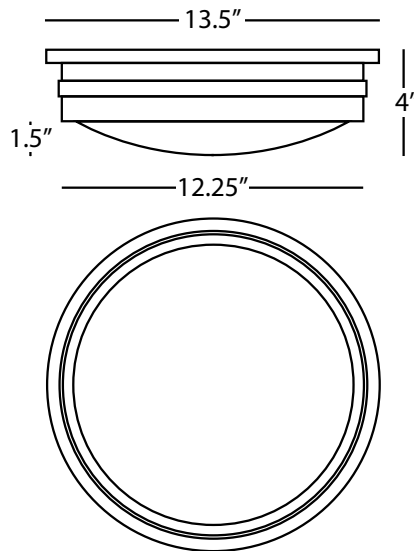

FINISH OPTIONS:

B1314 Antique Silver
C1314 Polished Chrome
S1314 Polished Nickel

RODERICK

C1317

17" Dia. Flush Mount

3 - 60W Max.
Bulb Type: B11 Torpedo
Direct Wire Only
Polished Chrome
White Frosted Glass Shade

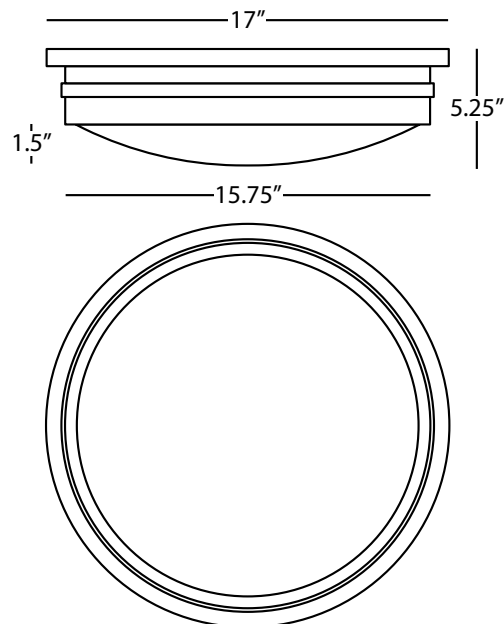

FINISH OPTIONS:

S1317 Polished Nickel
Z1317 Deep Patina Bronze



B1350

C1350

S1350

W1350

Z1350

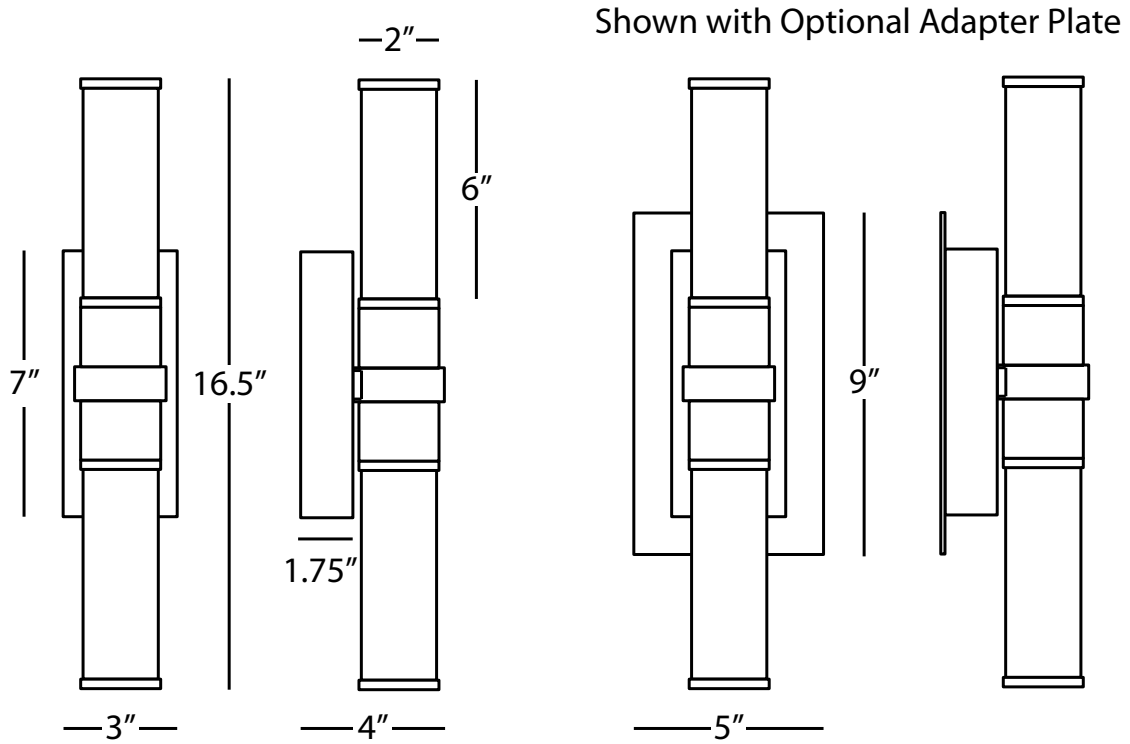

RODERICK

B1350

Bath Sconce

2 - 10W Max.
 Bulb Type: Solid State LED (Non-Replaceable)
 LED Color Temp: 3000K, CRI: 90+
 Lumen Output: 1600
 Direct Wire Only, Fully Dimmable
 Antique Silver Finish
 White Frosted Glass Shades
 UL Rated for Damp Locations
 ADA Compliant

FINISH OPTIONS:

C1350 Polished Chrome
S1350 Polished Nickel
W1350 Warm Brass
Z1350 Deep Patina Bronze

*Metal Junction Box Cover Plate in Matching Finish Included



S1530

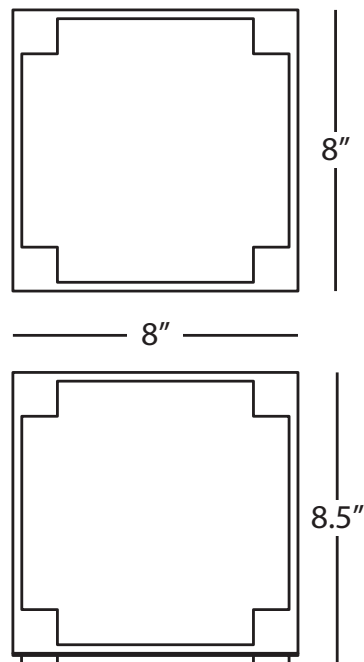

RUBIX

S1530

Cube Accent Lamp

1 - 15W Max.
(1200 Lumen Output)
Bulb Type: LED unit, Included (Non-Replaceable)
LED Color Temp: 3000, CRI: 90
Switch: Full Range Dimmer Line Switch
Polished Nickel Finish
Faux Alabaster Shade Panels



S2190



Z2181



S2195



Z2184

Saturnia

SATURNIA

Z2184

Accent Lamp

1 - 60W Max.
 Bulb Type: G16.5, Candelabra
 Switch: On-Off Line Switch
 Deep Patina Bronze Finish
 Bronze Transparent Fabric Exterior Shade w/
 Ascot White Fabric Interior Shade

FINISH/SHADE OPTION:

S2194 Stainless Steel Finish
 Silver Transparent Fabric
 Exterior Shade w/ Ascot White
 Fabric Interior Shade

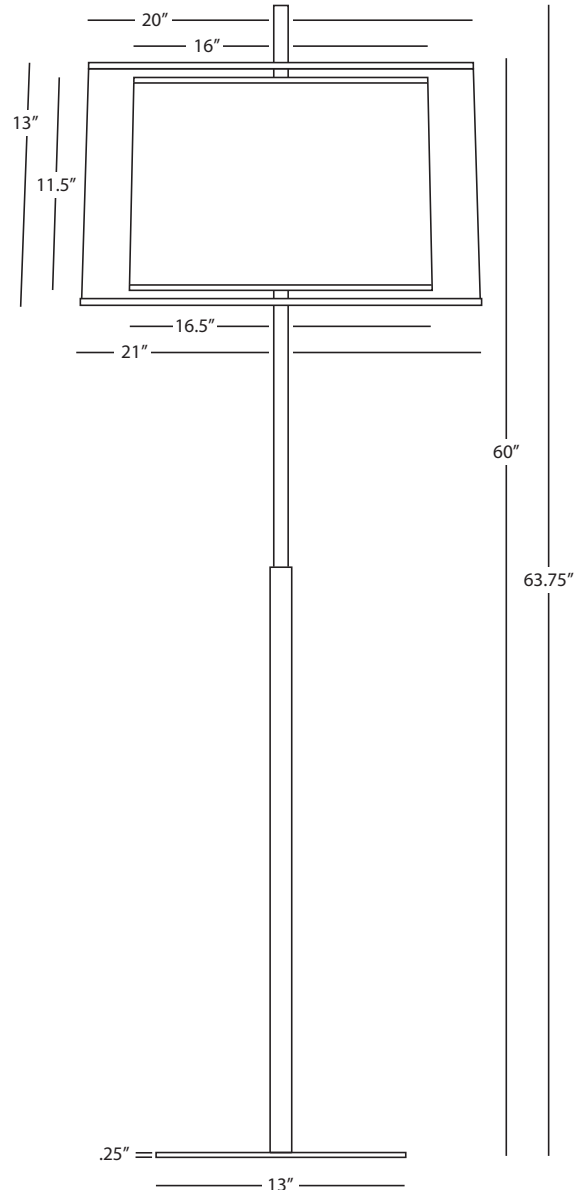
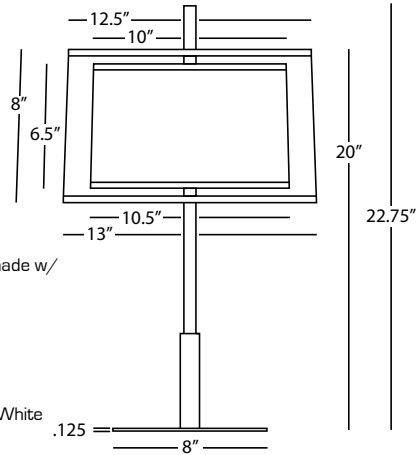

SATURNIA

S2195

Buffet Table Lamp

1 - 60W Max.
 Bulb Type: G16.5, Candelabra
 Switch: On-Off Line Switch
 Stainless Steel Finish
 Silver Transparent Fabric Exterior Shade w/
 Ascot White Fabric Interior Shade

FINISH/SHADE OPTION:

Z2185 Deep Patina Bronze Finish
 Bronze Transparent Fabric
 Exterior Shade w/ Ascot White
 Fabric Interior Shade

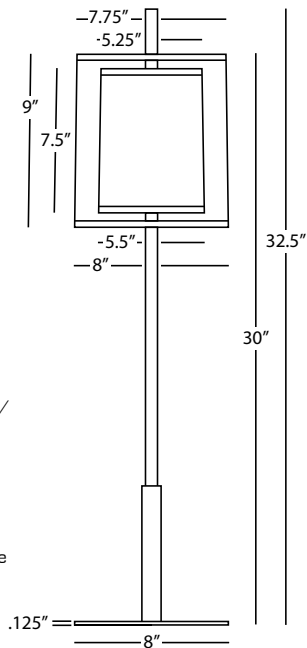

SATURNIA

S2190

Table Lamp

1 - 150W Max.
 Bulb Type: A
 Switch: 3-Way
 Stainless Steel Finish
 Silver Transparent Fabric Exterior Shade w/
 Ascot White Fabric Interior Shade

FINISH/SHADE OPTION:

Z2180 Deep Patina Bronze Finish
 Bronze Transparent Fabric
 Exterior Shade w/ Ascot White
 Fabric Interior Shade

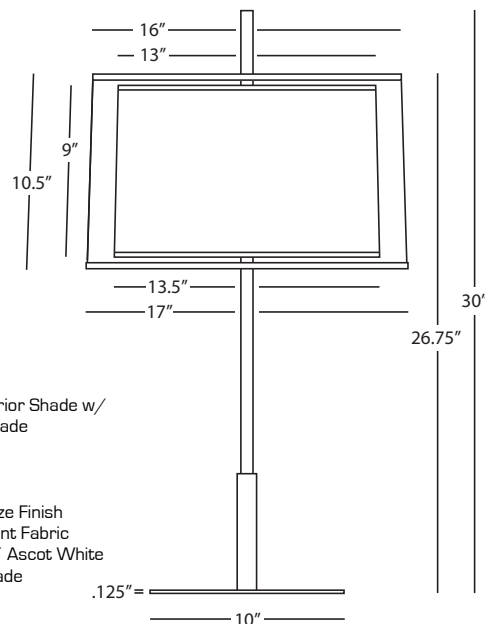

SATURNIA

Z2181

Floor Lamp

1 - 150W Max.
 Bulb Type: A
 Switch: 3-Way
 Deep Patina Bronze Finish
 Bronze Transparent Fabric Exterior Shade w/
 Ascot White Fabric Interior Shade

FINISH/SHADE OPTION:

S2191 Stainless Steel Finish
 Silver Transparent Fabric
 Exterior Shade w/ Ascot White
 Fabric Interior Shade



S2192



S2193



Z2187



S2198

Saturnia

SATURNIA

S2198 6-Light Chandelier

6 - 60W Max.
Bulb Type: G16.5 Candelabra
Direct Wire Only
Stainless Steel Finish
Silver Transparent Fabric Exterior Shades w/
Ascot White Fabric Interior Shades
Susp. Hardware: 3 pcs. 5/8" x 12" &
1 pc. 5/8" x 6" Extensions

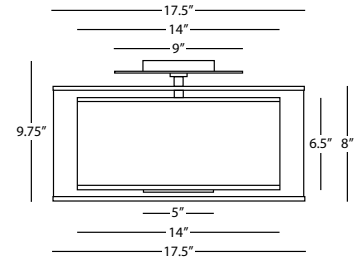
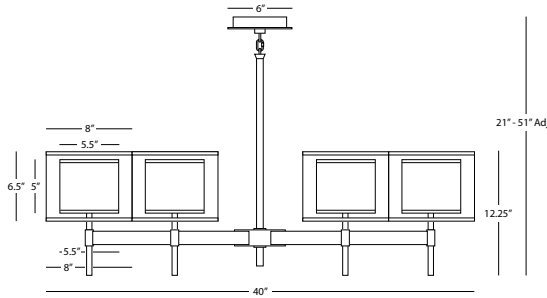
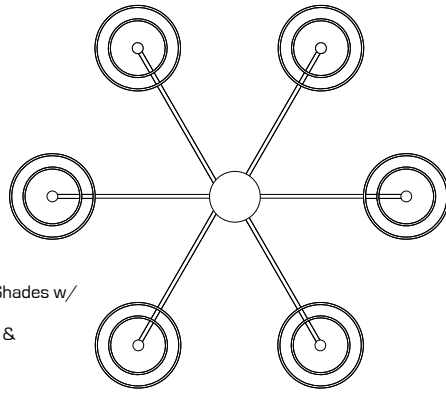

SATURNIA

Z2187 Semi-Flush Mount

2 - 100W Max.
Bulb Type: A
Direct Wire Only
Deep Patina Bronze Finish
Bronze Transparent Fabric Exterior Shade
w/ Ascot White Fabric Interior Shade
13.5" Dia. White Acrylic Diffuser

FINISH/SHADE OPTION:
S2197 Stainless Steel Finish
Silver Transparent Fabric
Exterior Shade w/ Ascot White
Fabric Interior Shade

SATURNIA

S2193 Pendant

3 - 100W Max.
Bulb Type: A
Direct Wire Only
Stainless Steel Finish
Silver Transparent Fabric Exterior Shade w/
Ascot White Fabric Interior Shade
19" Dia. White Acrylic Diffuser
Susp. Hardware: 3 pcs. 5/8" x 12" &
1 pc. 5/8" x 6" Extensions

FINISH/SHADE OPTION:
Z2183 Deep Patina Bronze Finish
Bronze Transparent Fabric
Exterior Shade w/ Ascot White
Fabric Interior Shade

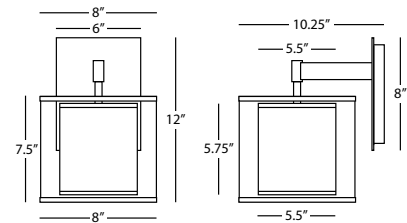
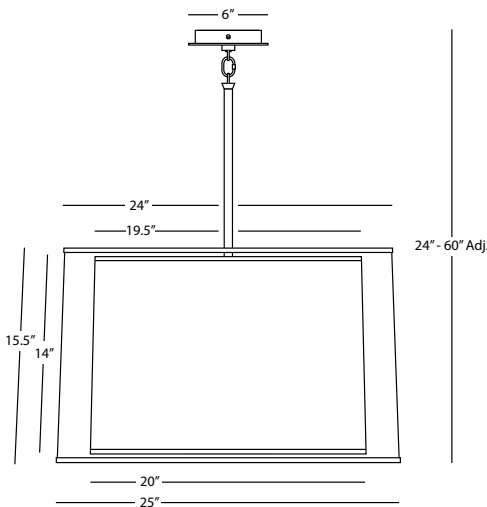

SATURNIA

S2192 Wall Sconce

1 - 60W Max.
Bulb Type: B, Candelabra
Switch: On-Off Line Switch
24" Cord Cover/Direct Wire
Stainless Steel Finish
Silver Transparent Fabric Exterior Shade
w/ Ascot White Fabric Interior Shade

FINISH/SHADE OPTION:
Z2182 Deep Patina Bronze Finish
Bronze Transparent Fabric
Exterior Shade w/ Ascot
White Fabric Interior Shade



Z2155

Saturnia

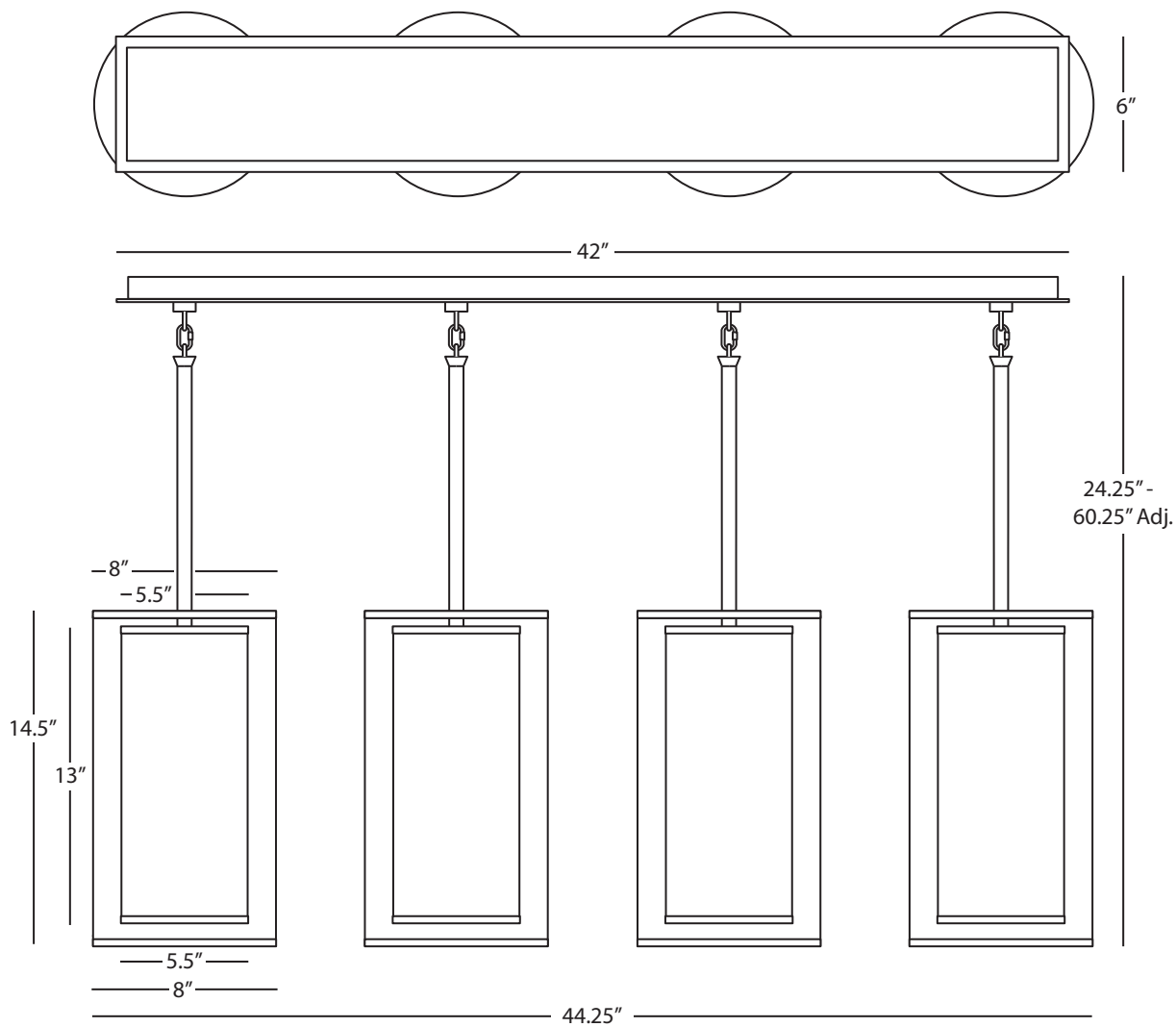

SATURNIA

Z2155

Linear Chandelier

4 - 60W Max.
Bulb Type: B, Candelabra
Direct Wire
Deep Patina Bronze Finish
Bronze Transparent Fabric
Exterior Shades w/ Ascot
White Fabric Interior Shades
Susp. Hardware: 12 pcs. 5/8" x 12" &
4 pcs. 5/8" x 6" Extensions



1597



S1551

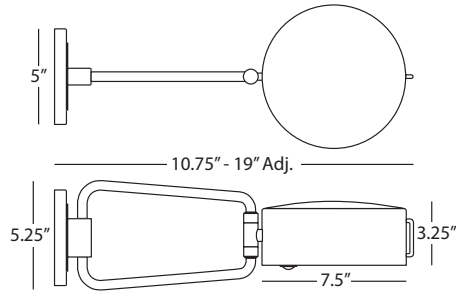

SIMON

1597 Swing Arm Sconce

1 - 60W Max.
Bulb Type: A
Switch: Hi-Lo Dimming
24" Cord Cover/Direct Wire
Satin Black Finish w/
Modern Brass Accents
Adjustable Metal Shade

SIMON

S1551 Chandelier

6 - 60W Max.
Bulb Type: A
Direct Wire
Satin Black Finish w/
Polished Nickel Finished Accents
Adjustable Metal Shades
Susp. Hardware: 3 pcs. 5/8" x 12" & 1
pc. 5/8" x 6" Extensions

FINISH OPTION:
1551 Satin Black Finish w/
Modern Brass Accents

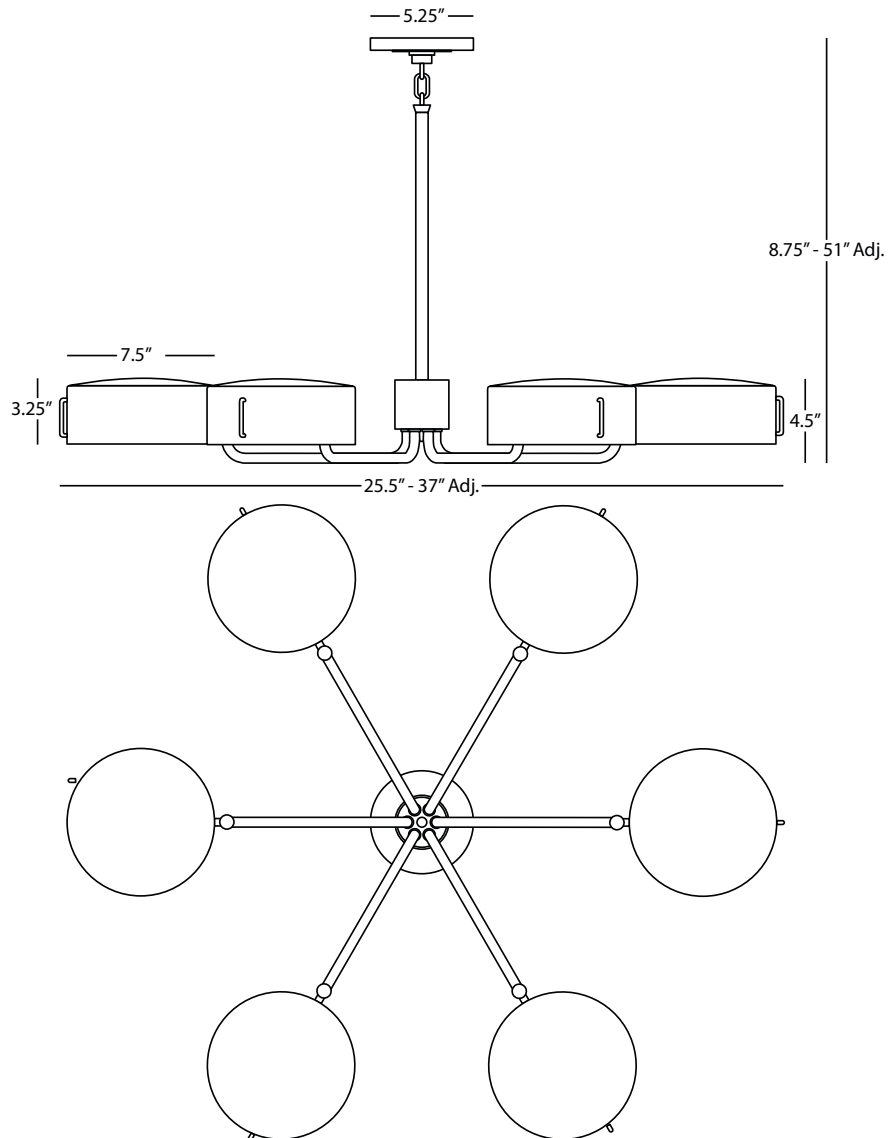



1957



1958



1957B



1958B

SLOAN

1957

Table Lamp

2 - 100W Max.
 Bulb Type: A
 Switch: On-Off Pull Chains
 Lead Crystal w/ Aged Brass Accents
 Rectangular Ivory Silk Box Pleat Shade
 w/ Off-White Silk Lining

SHADE OPTION:

1957B Black Painted Opaque Parchment
 Matte Gold Lining

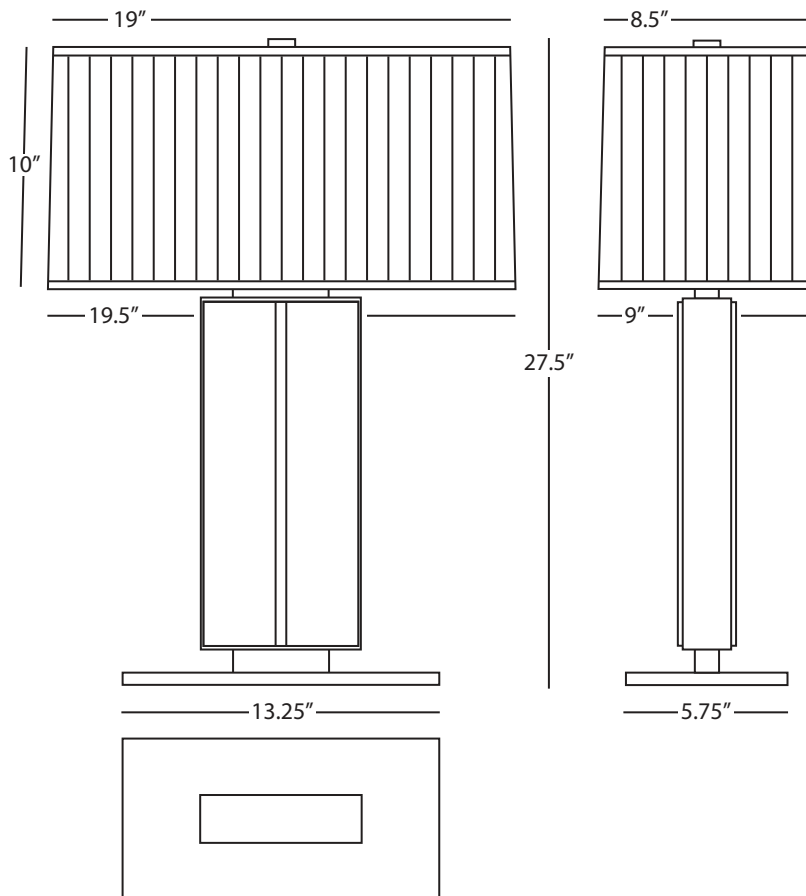

SLOAN

1958B

Wide Table Lamp

2 - 100W Max.
 Bulb Type: A
 Switch: On-Off Pull Chains
 Lead Crystal w/ Aged Brass Accents
 Rectangular Black Painted Opaque Parchment Shade
 w/ Matte Gold Lining

SHADE OPTION:

1958 Ivory Silk Box Pleat Shade
 Off-White Silk Lining

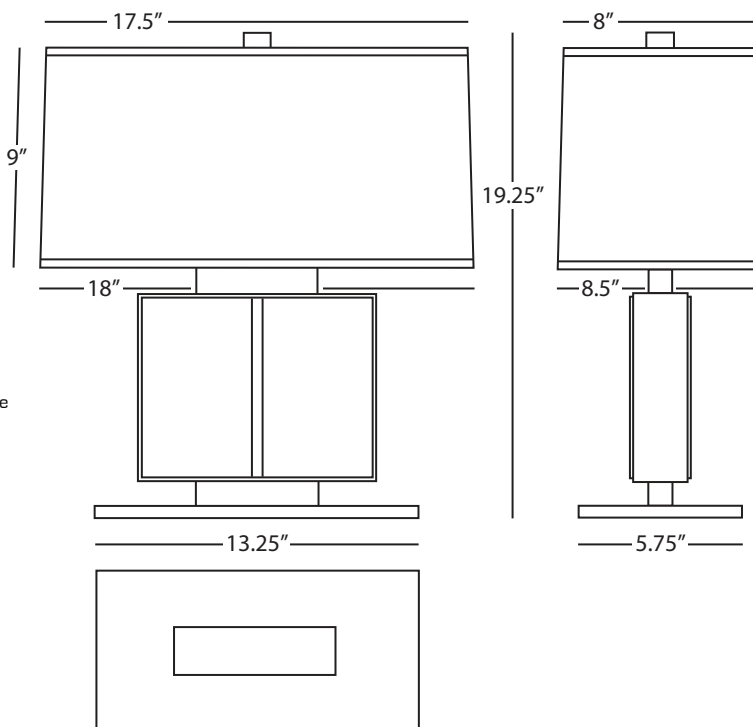



2824



D2824



Z2824

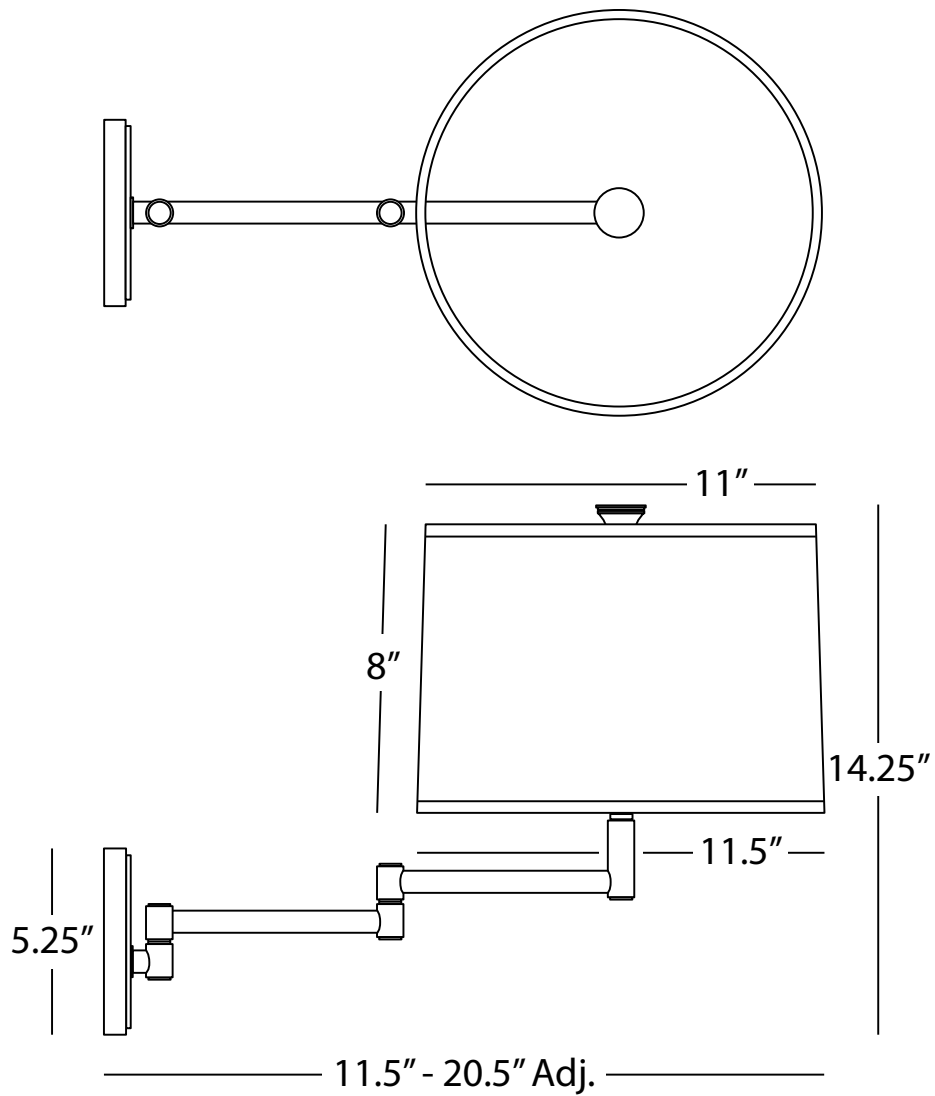

SOFIA

2824

Swing Arm Wall Sconce

1 - 100W Max.

Bulb Type: A

Switch: Hi-Lo Dimming

24" Cord Cover/Direct Wire

Antique Brass Finish

Open Weave White Linen Shade

FINISH/SHADE OPTIONS:

- D2824** Dark Antique Nickel
- Open Weave White Linen
- Z2824** Deep Patina Bronze
- Open Weave Heather Linen

Thatcher



| Thatcher

Click photo above to watch Thatcher Floor Lamp Video

| A crossed leg design defines the Thatcher collection while matte black and polished metal accents add to its sleek, modern appeal.

| Thatcher



| Thatcher

Click photo above to watch Thatcher Table Lamp Video

| A crossed leg design defines the Thatcher collection while matte black and polished metal accents add to its sleek, modern appeal.



S218



217

Thatcher

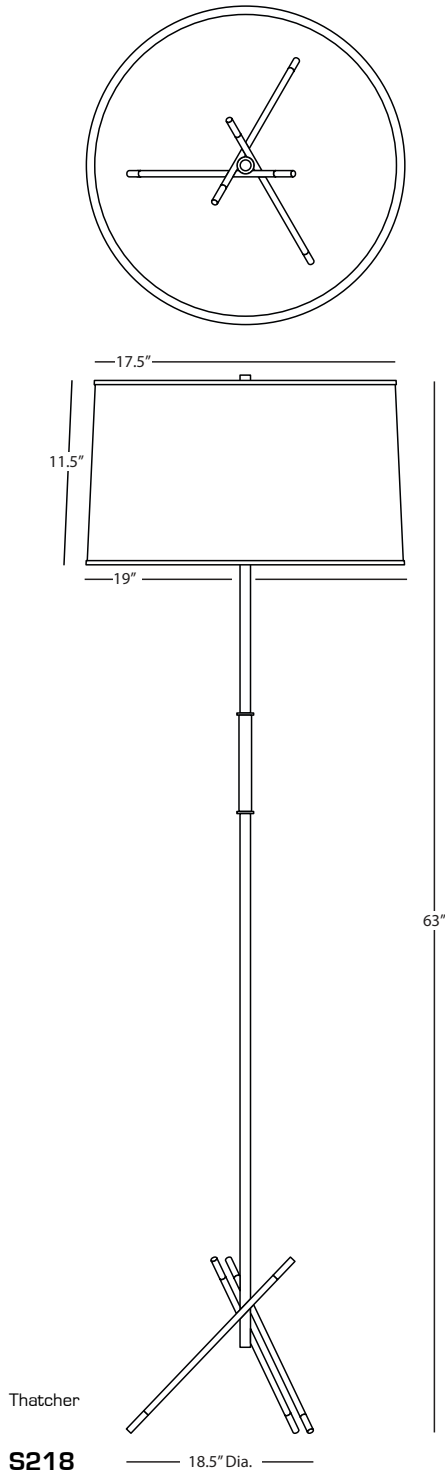

S218
Floor Lamp

1 - 150W Max.
Bulb Type: A
Switch: Full Range Dimmer
Matte Black Painted Finish
Polished Nickel Accents
Oyster Linen Shade

FINISH OPTIONS:
218 Modern Brass

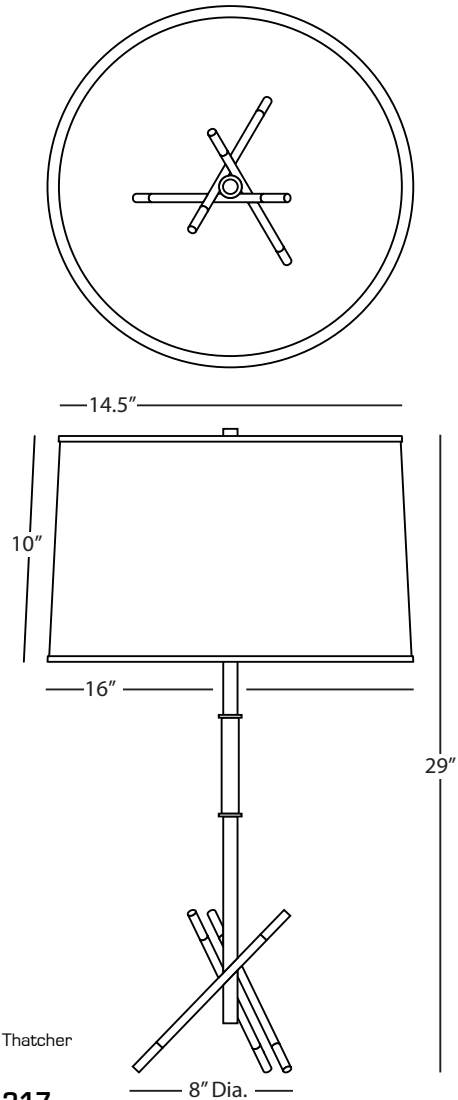

217
Table Lamp

1 - 150W Max.
Bulb Type: A
Switch: Full Range Dimmer
Matte Black Painted Finish
Modern Brass Accents
Oyster Linen Shade

FINISH OPTIONS:
S217 Polished Nickel



219



S221

Thatcher

Thatcher

219 Chandelier

12 - 60W Max.
Bulb Type: A
Direct Wire Only
Matte Black Painted Finish
Modern Brass Accents
Susp. Hardware: 3 pcs - 5/8" x 12"
& 1pc - 5/8" x 6" Extension Rods

FINISH OPTIONS:
S219 Polished Nickel/Matte Black Painted

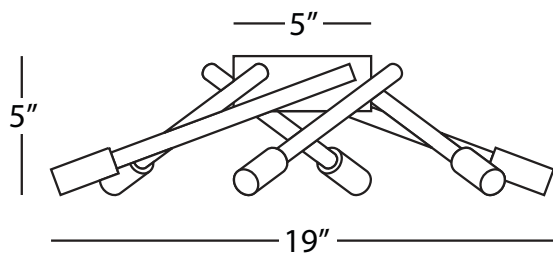
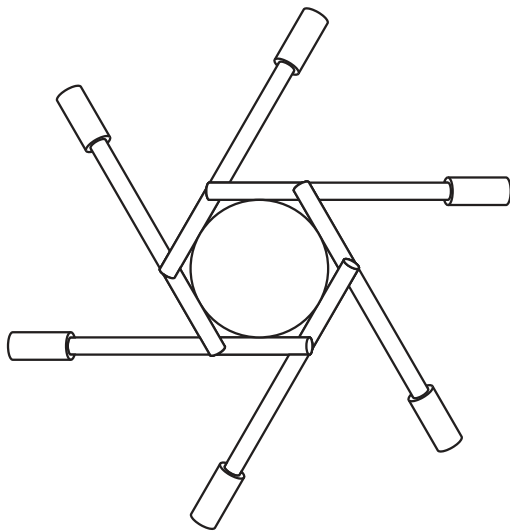
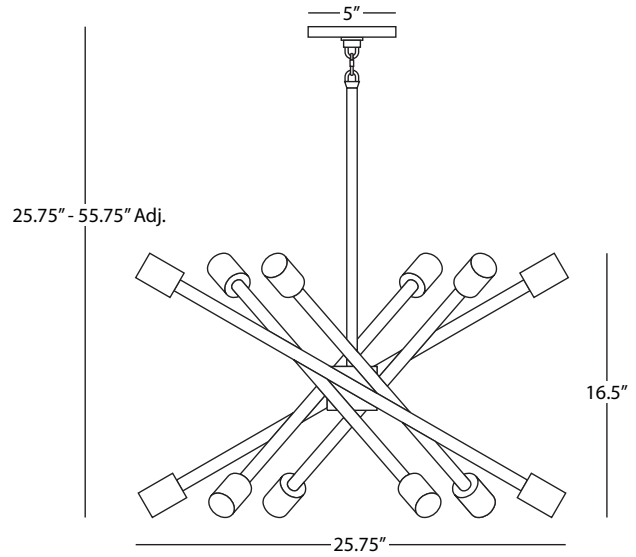
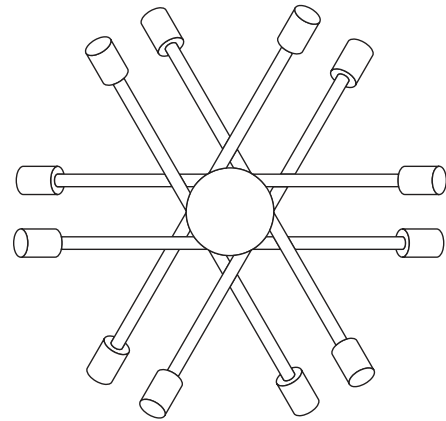

Thatcher

S221 Flush Mount

6 - 40W Max.
Bulb Type: B (Candelabra Base)
Direct Wire Only
Matte Black Painted Finish
Polished Nickel Accents

FINISH OPTIONS:
221 Modern Brass/Matte Black Painted



Tic-Tac-Toe

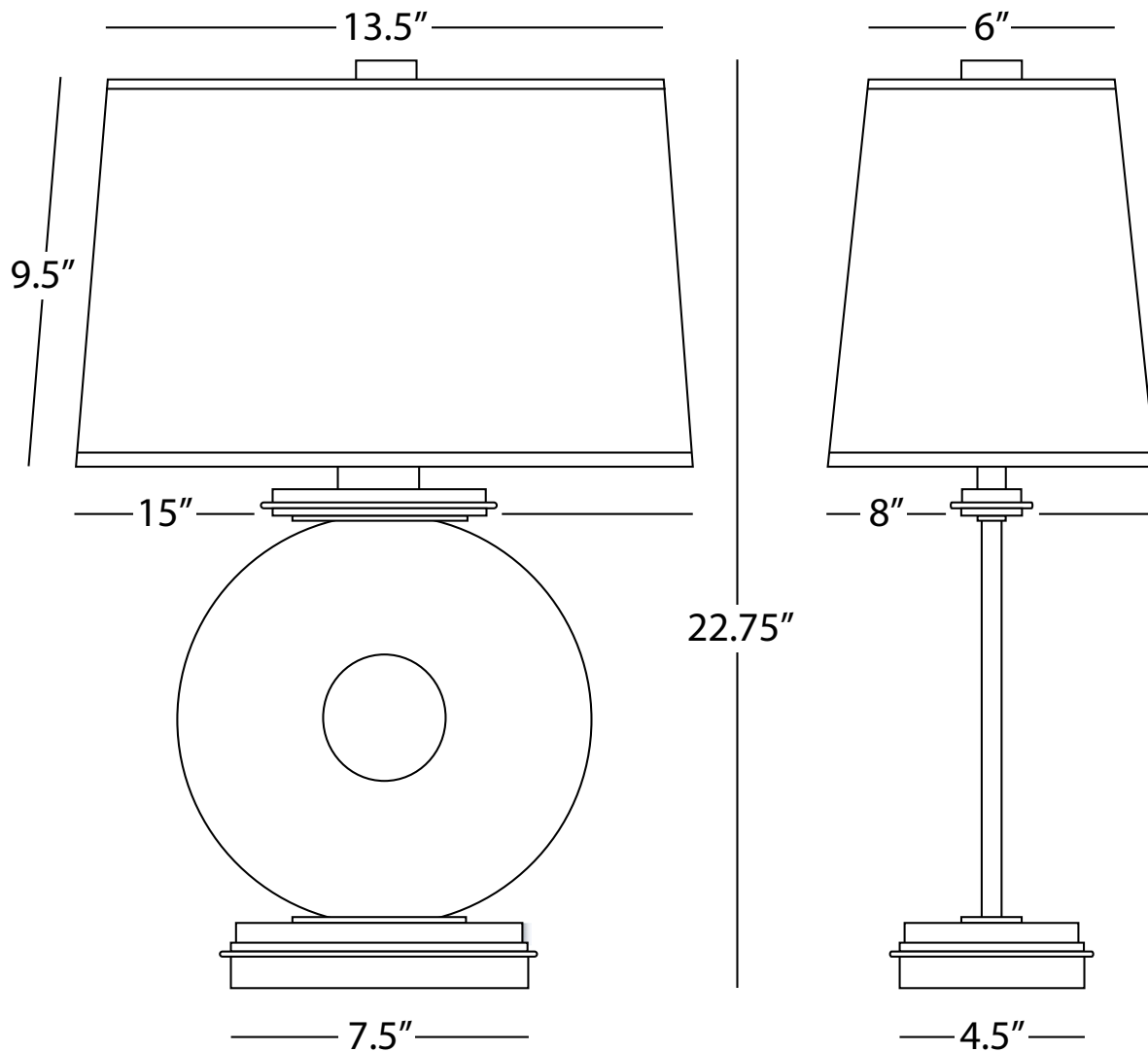

TIC-TAC-TOE

125 Table Lamp

1 - 150W Max.
Bulb Type: A
Switch: 3-Way
Antique Brass Finish w/ Black Marble Accents
Rectangular Pale Shell Dupioni Fabric Shade

Triple Gourd



378X



A282X



EG31X



A368X



RR42X

Triple Gourd

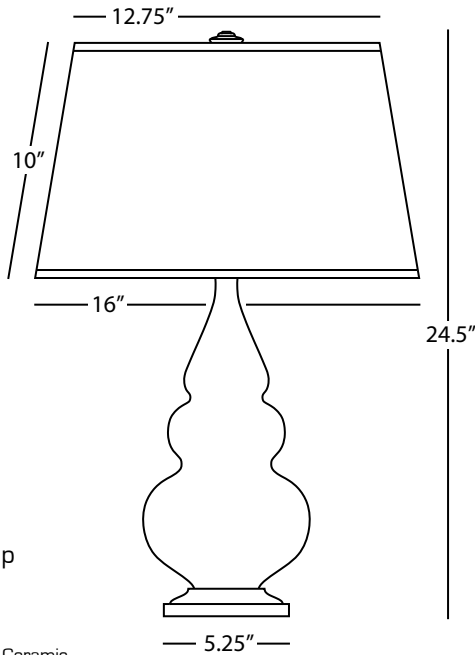

TRIPLE GOURD

378X Accent Lamp

1 - 150W Max.
Bulb Type: A
Switch: 3-Way
Amethyst Glazed Ceramic
Antique Brass Finished Accents
Pearl Dupioni Fabric Shade

See Page 506 for Color/Base/Shade Options

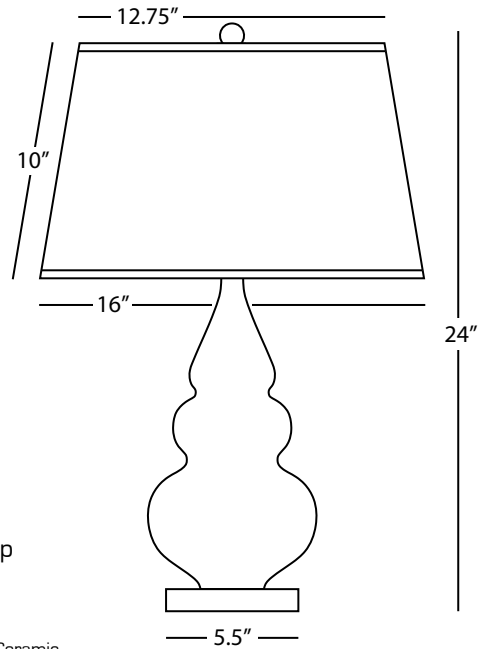

TRIPLE GOURD

A282X Accent Lamp

1 - 150W Max.
Bulb Type: A
Switch: 3-Way
Pumpkin Glazed Ceramic
Square Lucite Base
Pearl Dupioni Fabric Shade

See Page 506 for Color/Base/Shade Options

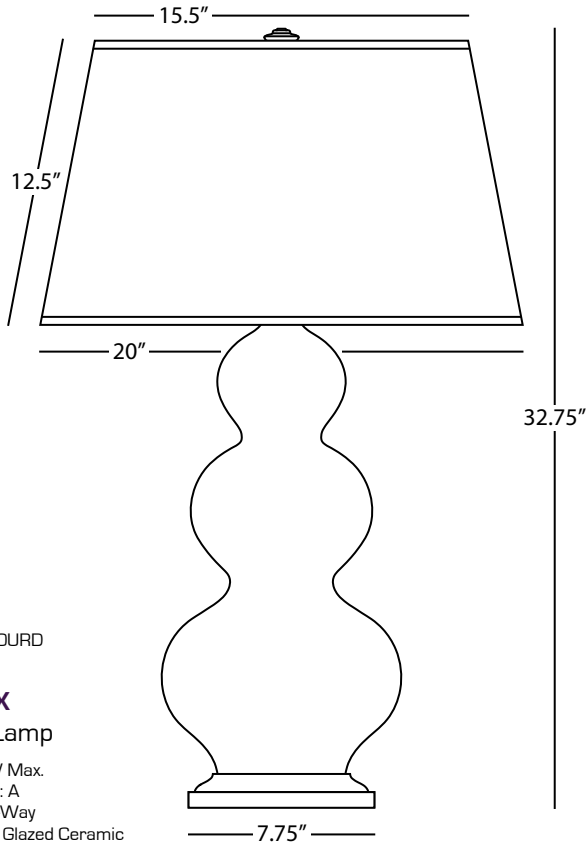

TRIPLE GOURD

RR42X Table Lamp

1 - 150W Max.
Bulb Type: A
Switch: 3-Way
Ruby Red Glazed Ceramic
Antique Silver Finished Accents
Pearl Dupioni Fabric Shade

See Page 506 for Color/Base/Shade Options

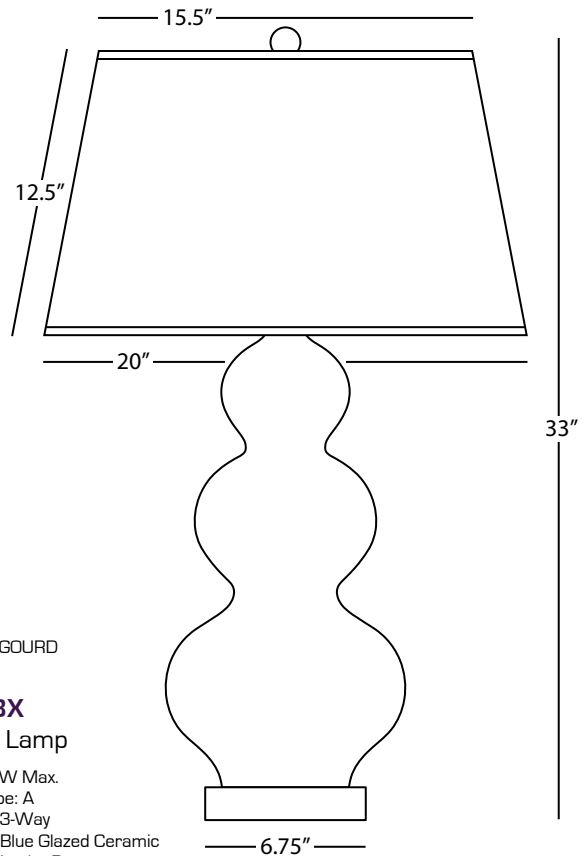

TRIPLE GOURD

A368X Table Lamp

1 - 150W Max.
Bulb Type: A
Switch: 3-Way
Marine Blue Glazed Ceramic
Square Lucite Base
Pearl Dupioni Fabric Shade

See Page 506 for Color/Base/Shade Options



B1310



C1310



S1310



Z1310

Tyrone

— 3" —

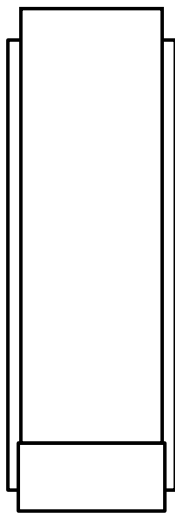

— 4" —

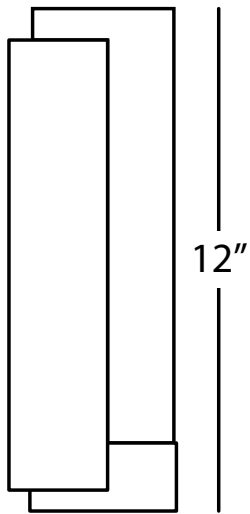

— 4" —

Shown with Optional
Junction Box Cover Plate

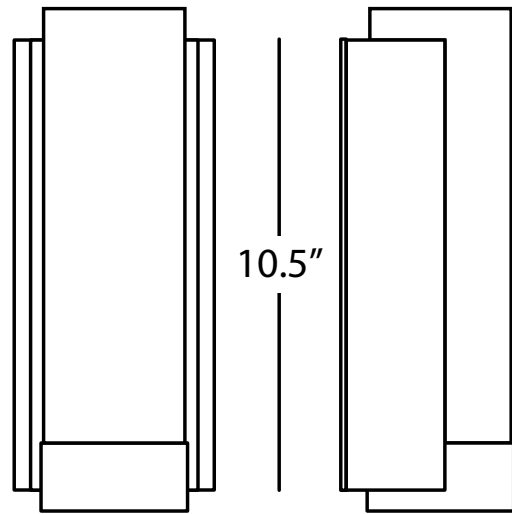

— 5" —

TYRONE

B1310

Wall Sconce

1 - 60W Max.
Bulb Type: A
Direct Wire Only
Antique Silver Finish
White Frosted Glass Shade
UL Rated for Damp Locations
ADA Compliant

FINISH OPTIONS:

C1310 Polished Chrome
S1310 Polished Nickel
Z1310 Deep Patina Bronze

*Metal Junction Box Cover Plate in Matching Finish Included

Valerie



Valerie

[Click photo above to watch Valerie Floor Lamp Video](#)

Dynamic angles, clean lines, and a sturdy base give the Valerie collection a bold and dauntless presence. This collection is ideal for making an eye catching statement in your contemporary or modern space.

| Valerie

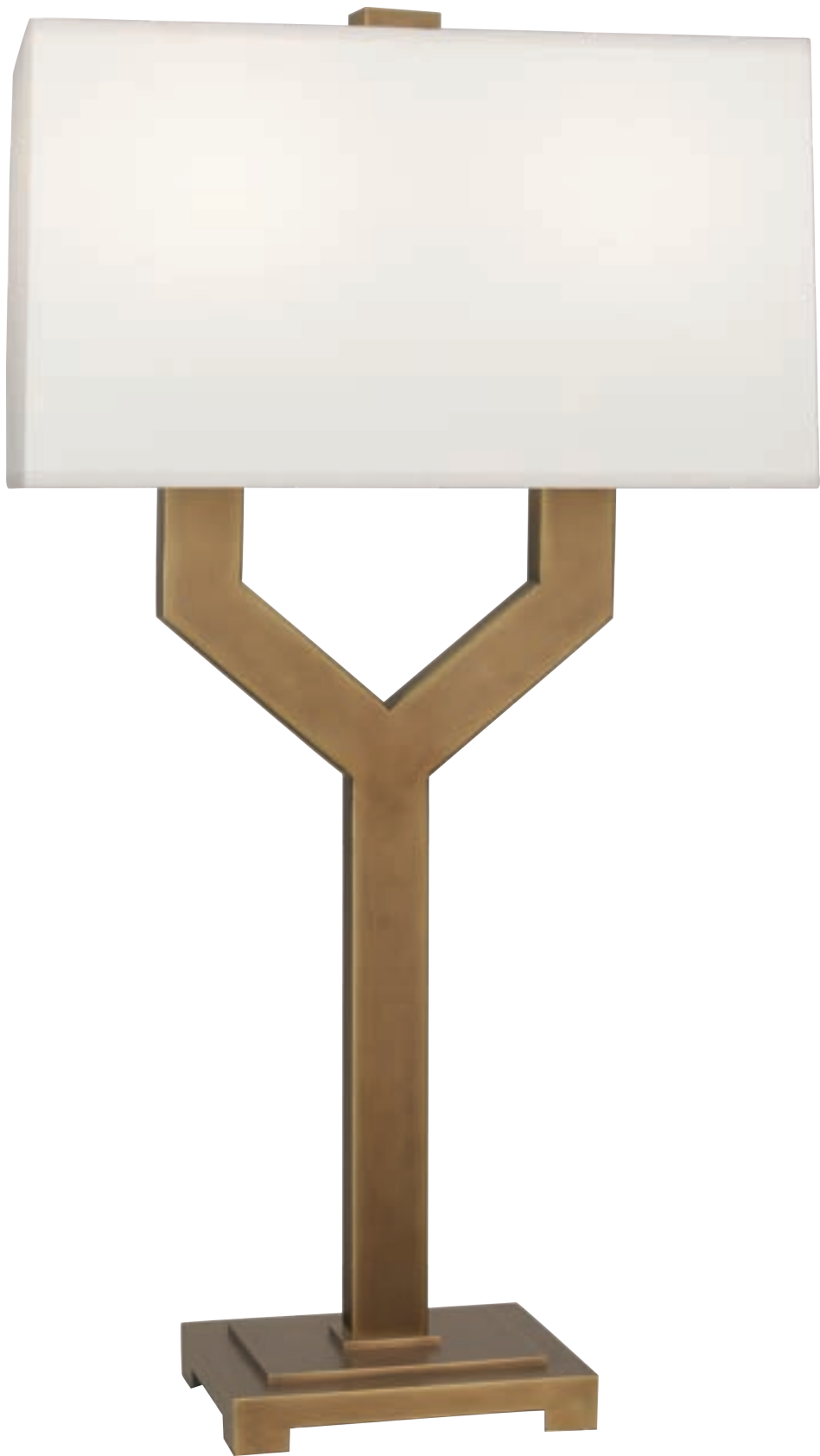

Valerie

[Click photo above to watch Valerie Table Lamp Video](#)

Dynamic angles, clean lines, and a sturdy base give the Valerie collection a bold and dauntless presence. This collection is ideal for making an eye catching statement in your contemporary or modern space.

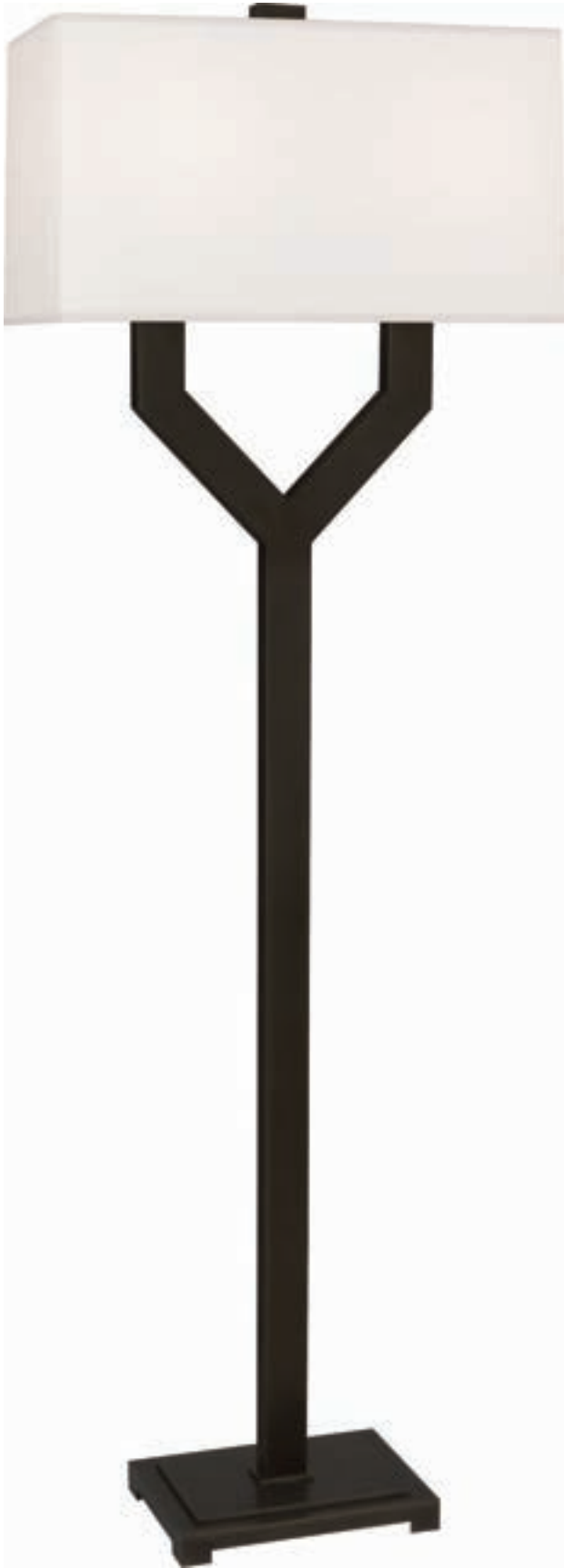

Z821

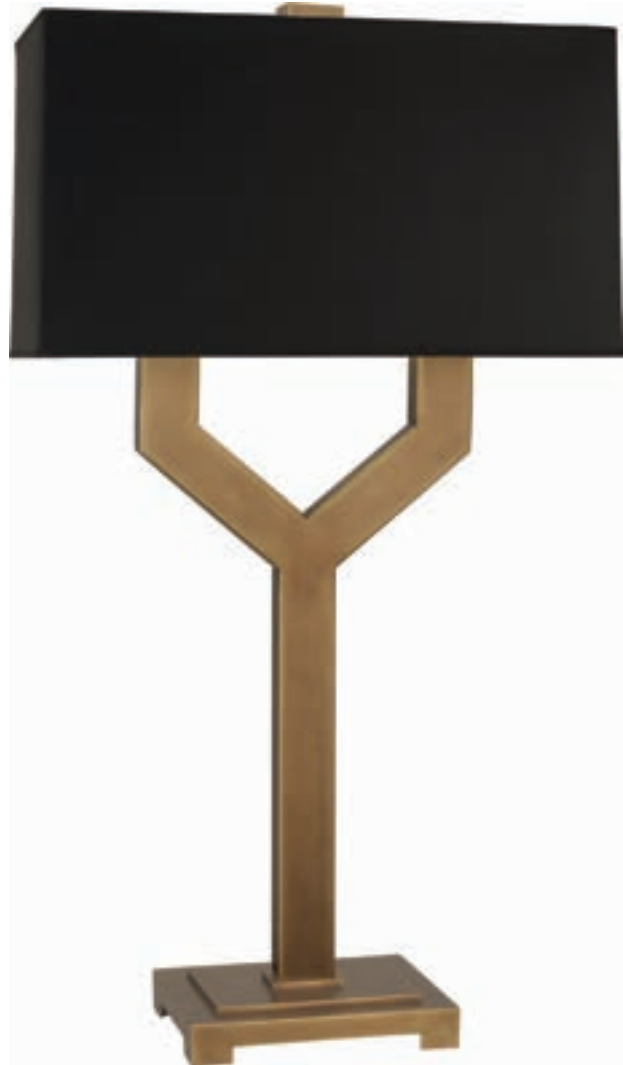

820B

Valerie

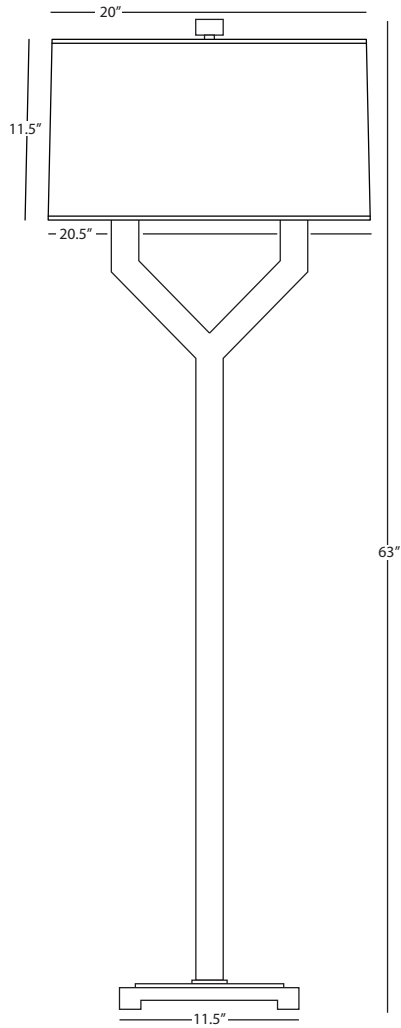

Valerie

821 Floor Lamp

2 - 100W Max.
Bulb Type: A
Switch: Full Range Dimmer Line Switch
Deep Patina Bronze Finish
Rectangular Fondine Fabric Shade

FINISH OPTIONS:

821 Vintage Brass / Fondine
821B Vintage Brass / Black Painted Opaque Parchment

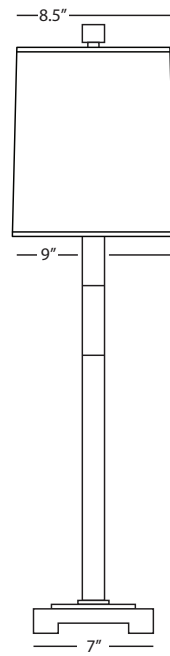
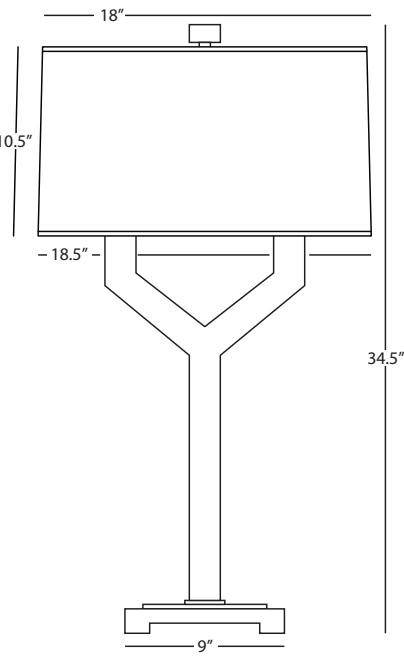
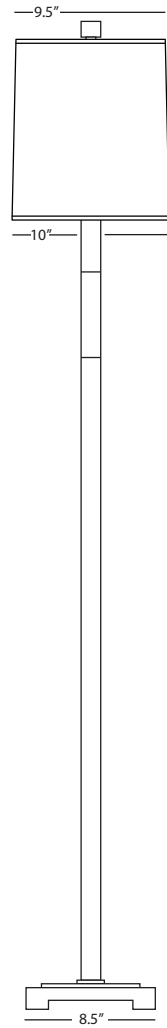

Valerie

820B Table Lamp

2 - 100W Max.
Bulb Type: A
Switch: Full Range Dimmer Line Switch
Vintage Brass Finish
Rectangular Black Painted Opaque Parchment Shade with Matte Gold Lining

FINISH OPTIONS:

820 Vintage Brass / Fondine
820B Deep Patina Bronze / Fondine

| Victor



Victor

[Click photo above to watch Victor Table Lamp video](#)

The Victor collection features a simple silhouette with a gentle taper that blends well with a range of styles. Available in a wide array of colors, this table lamp can create gorgeous contrast for your space or add just the right amount of a certain hue.



MB03



AP03



LY03



CR03



EB03



EG03

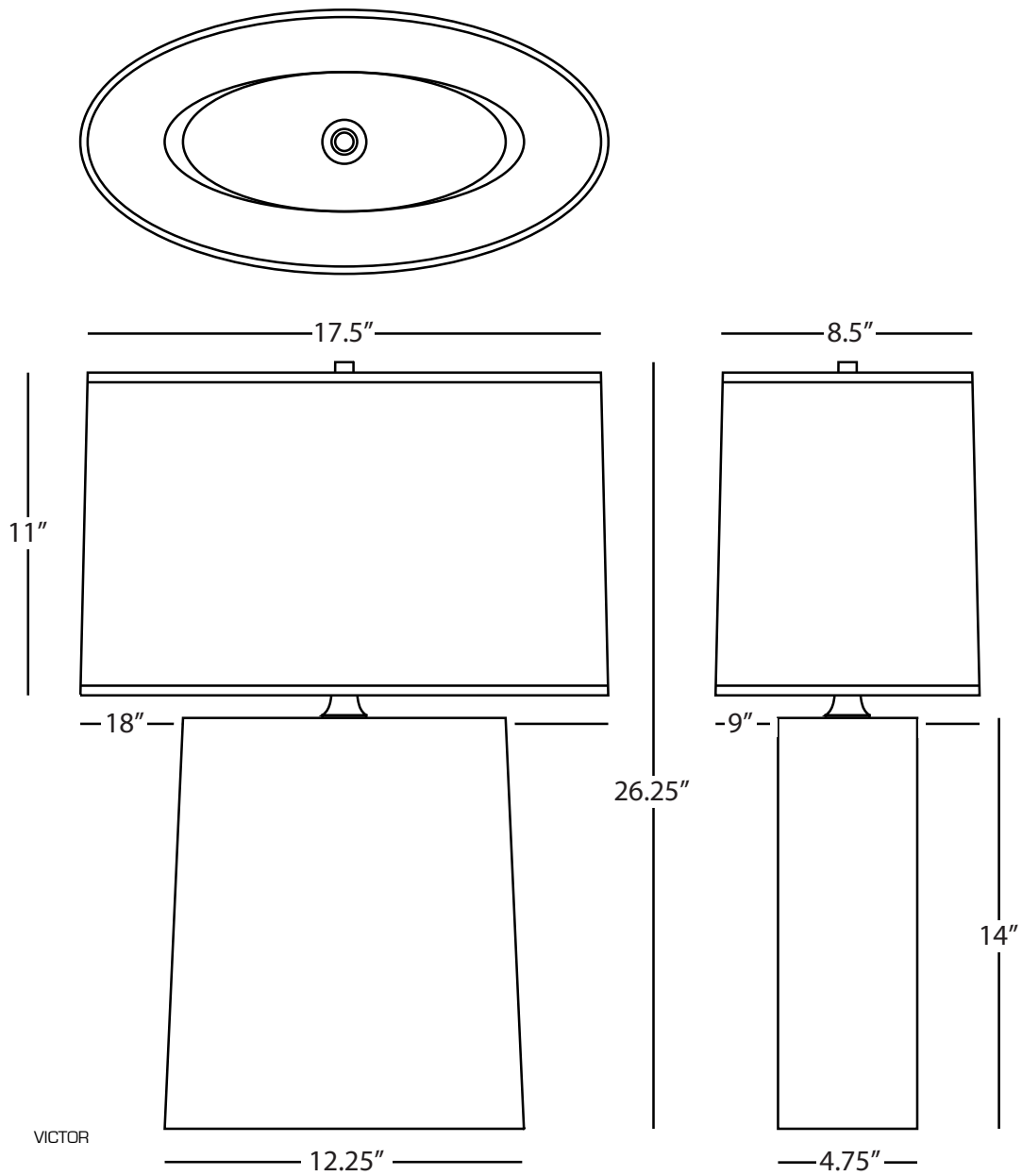

VICTOR

MB03
Table Lamp

1 - 100W Max.
Bulb Type: A
Switch: Full Range Dimmer
Midnight Blue Glazed Ceramic
Midnight Blue Accents
Oval Ascot White Shade

See Page 507 for Color Options



434



435

Wavy

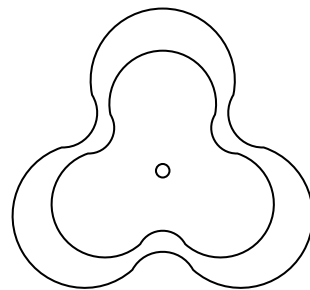
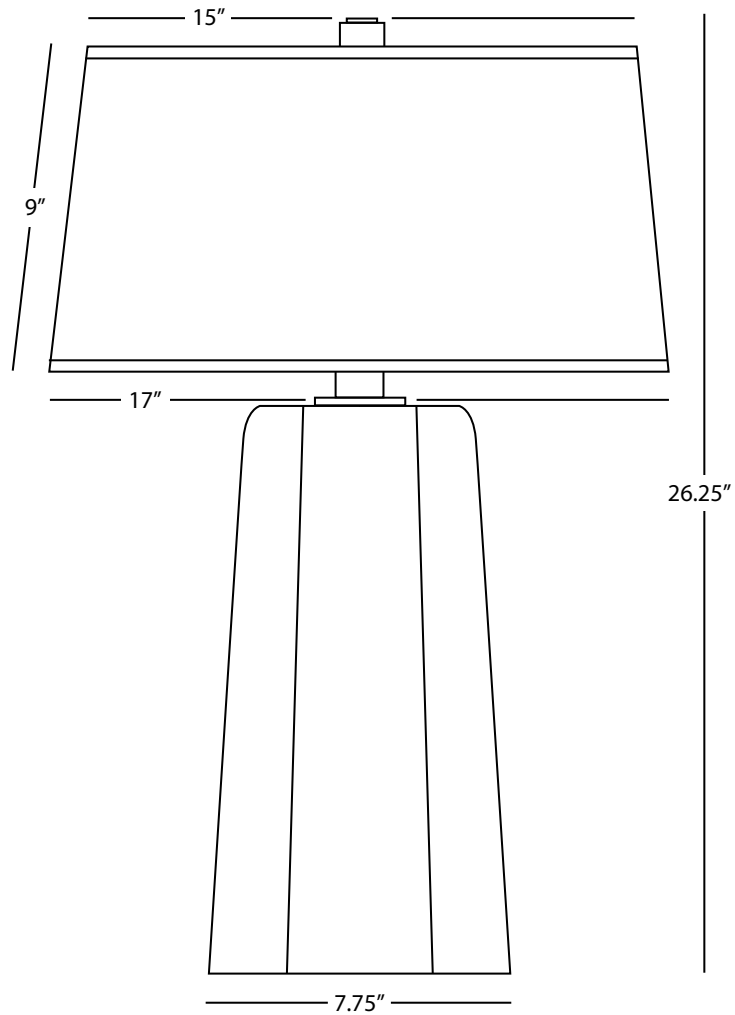

WAVY

434 Table Lamp

1 - 100W Max.
Bulb Type: A
Switch: Full Range Dimmer
White Cased Glass w/ Polished Nickel Accents
Translucent White Mont Blanc Parchment Shade

FINISHOPTION:
435 Silver Mercury Glass



253



Z252

Wheatley

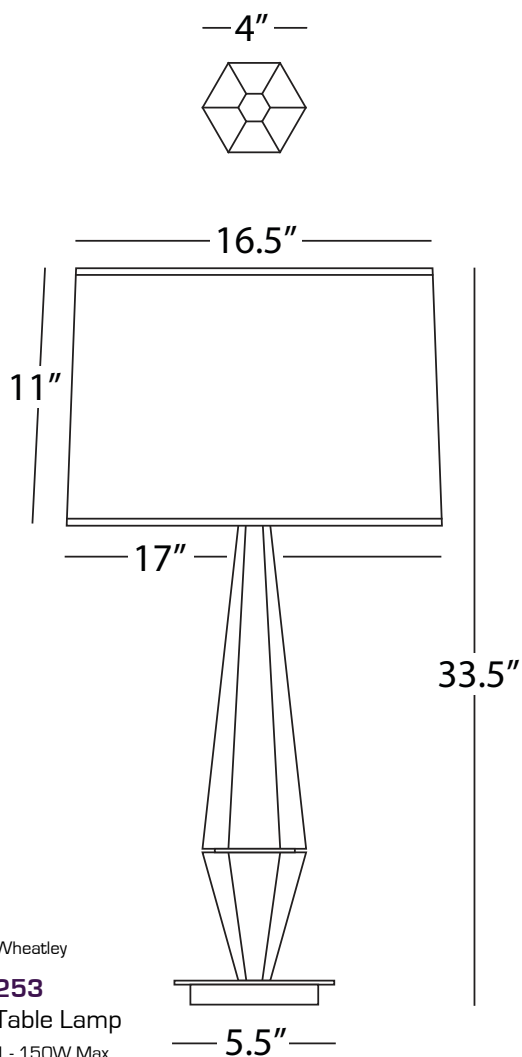

Wheatley

253

Table Lamp

1 - 150W Max.

Bulb Type: A

Switch: Full Range Dimmer

Warm Brass Finish

Ascot White Fabric Shade

FINISH OPTIONS:

Z253 Deep Patina Bronze

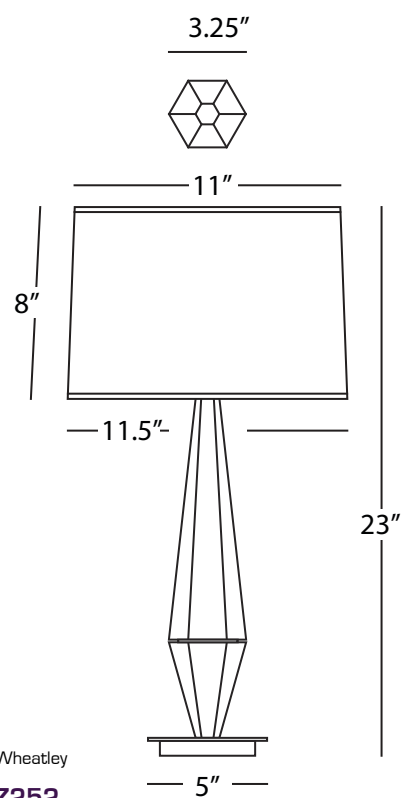

Wheatley

Z252

Accent Lamp

1 - 100W Max.

Bulb Type: A

Switch: Full Range Dimmer Line Switch

Deep Patina Bronze Finish

Ascot White Fabric Shade

FINISH OPTIONS:

252 Warm Brass



C257C



257C



Z257C



257F



C257F



Z257F

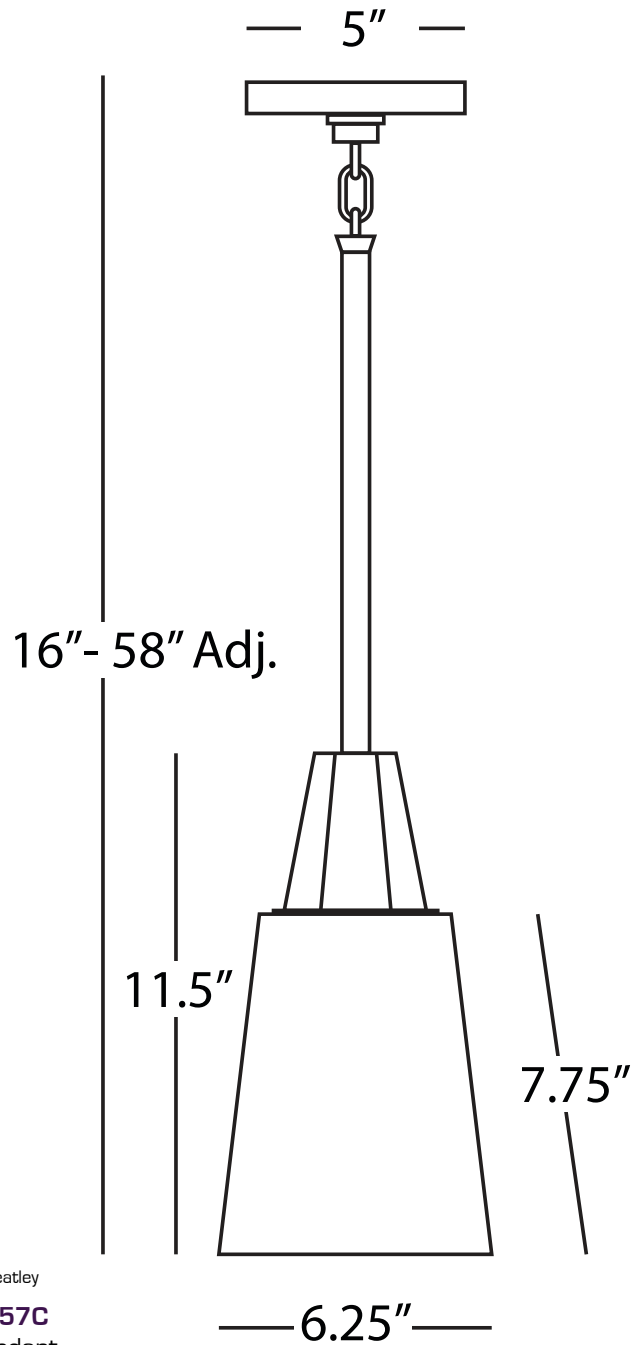

Wheatley

C257C
Pendant

1 - 60W Max.
Bulb Type: A
Direct Wire Only
Polished Chrome Finish
Clear Glass Shade
Susp. Hardware: 3 pcs - 5/8" x 12"
& 1pc - 5/8" x 6" Extension Rods

FINISH OPTIONS:

- C257F** Polished Chrome/Cased White Glass
- 257F** Modern Brass/Cased White Glass
- 257C** Modern Brass/Clear Glass
- Z257F** Deep Patina Bronze/Cased White Glass
- Z257C** Deep Patina Bronze/Clear Glass

254F



Z255C

C256F



Wheatley

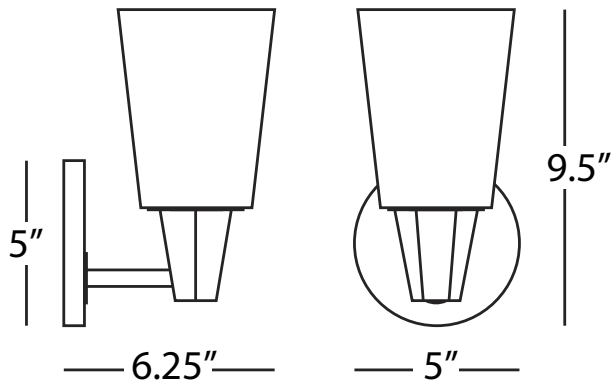

Wheatley

254F Wall Sconce

1 - 60W Max.
Bulb Type: A
24" Cord Cover/Direct Wire
Switch: On/Off Line Switch
Modern Brass Finish
Cased White Glass Shade

FINISH OPTIONS:

254C Modern Brass/Clear White Glass
C254F Polished Chrome/Cased White Glass
C254C Polished Chrome/Clear Glass
Z254F Deep Patina Bronze/Cased White Glass
Z254C Deep Patina Bronze/Clear Glass

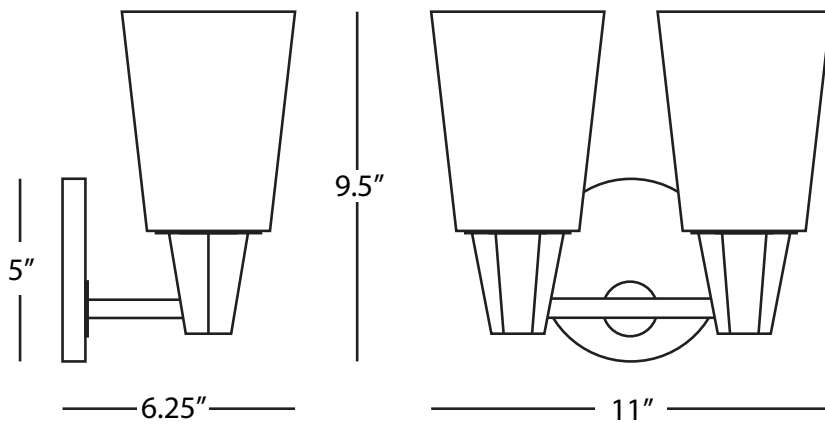

Wheatley

Z255C Wall Sconce

2 - 60W Max.
Bulb Type: A
24" Cord Cover/Direct Wire
Switch: On/Off Line Switch
Deep Patina Bronze Finish
Clear Glass

FINISH OPTIONS:

255F Modern Brass/Cased White Glass
255C Modern Brass/Clear Glass
C255F Polished Chrome/Cased White Glass
C255C Polished Chrome/Clear Glass
Z255F Deep Patina Bronze/Cased White Glass

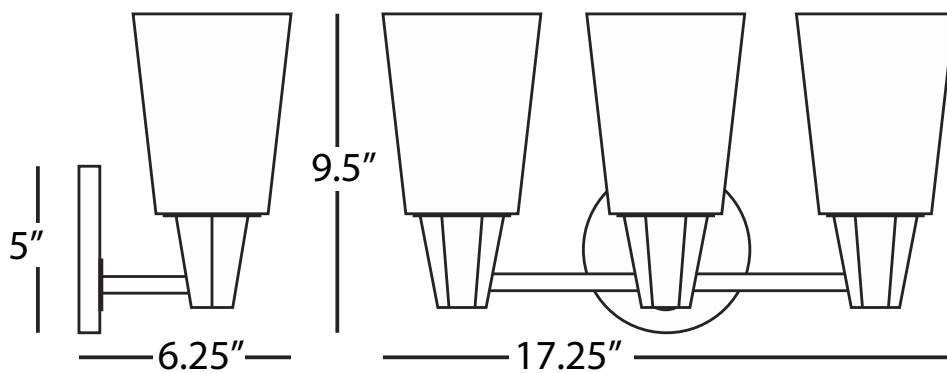

Wheatley

C256F Wall Sconce

3 - 60W Max.
Bulb Type: A
24" Cord Cover/Direct Wire
Switch: On/Off Line Switch
Polished Chrome Finish
Cased White Glass Shade

FINISH OPTIONS:

256F Modern Brass/Cased White Glass
256C Modern Brass/Clear Glass
C256C Polished Chrome/Clear Glass
Z256F Deep Patina Bronze/Cased White Glass
Z256C Deep Patina Bronze/Clear Glass



2607X



2609X



2606X

WILTON

2609X Table lamp

1 - 150W Max.
Bulb Type: A
Switch: 3-Way
Antique Rust Finish
Golden Saki Fabric Shade

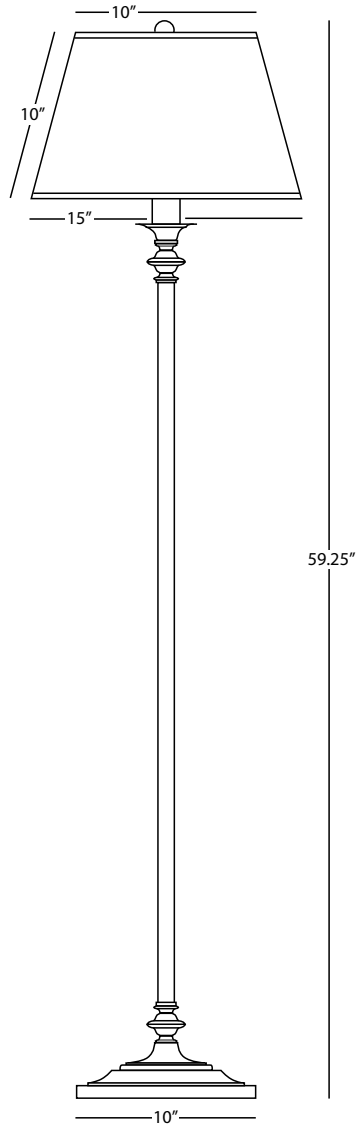
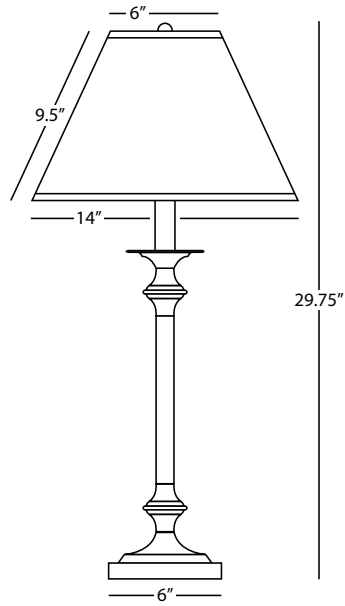

WILTON

2606X Club Floor Lamp

1 - 150W Max.
Bulb Type: A
Switch: 3-Way
Antique Rust Finish
Golden Saki Fabric Shade

WILTON

2607X Swing Arm Floor Lamp

1 - 150W Max.
Bulb Type: A
Switch: 3-Way
Antique Rust Finish
Golden Saki Fabric Shade

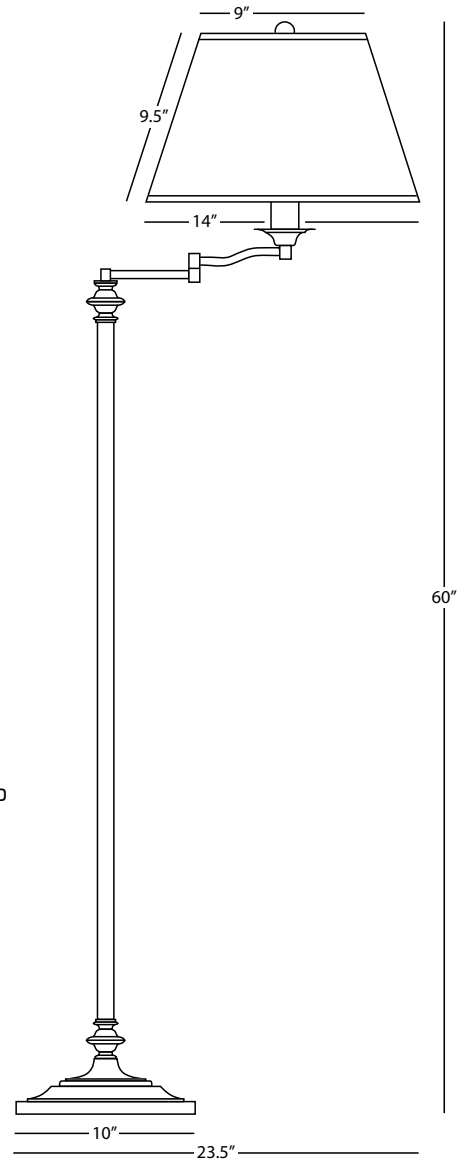



S4237



4237

Wonton

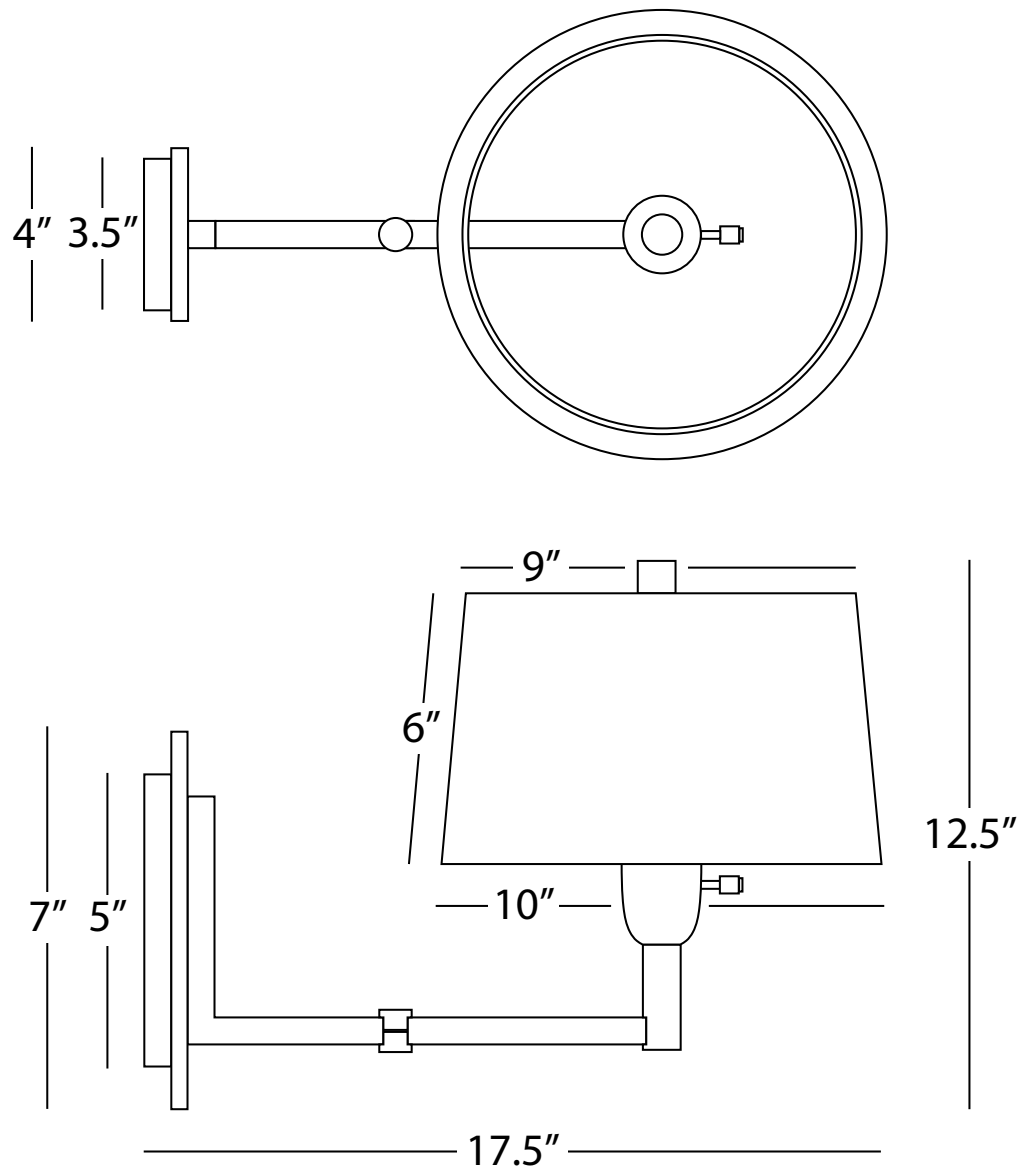

WONTON

S4237

Swing Arm Sconce

1 - 100W Max.
Bulb Type: A
Switch: Full Range Dimmer
24" Cord Cover/Direct Wire
Silver Plate Finish w/
Weathered Ebony Finished Wood Accents
Off-White Linen Shade w/ Rolled Edge Hem

FINISH/SHADE OPTION:

4237 Deep Patina Bronze w/ Cherry Finished Wood
Light Beige Linen Shade w/ Rolled Edge Hem



S251



250



Z251

WYATT

250

24" Picture Light

2 - 25W Max.
 Bulb Type: B, Medium Base
 Switch: On-Off Line Switch
 24" Cord Cover/Direct Wire
 Modern Brass Finish
 Metal Shade

FINISH OPTIONS:

S250 Polished Nickel
Z250 Deep Patina Bronze

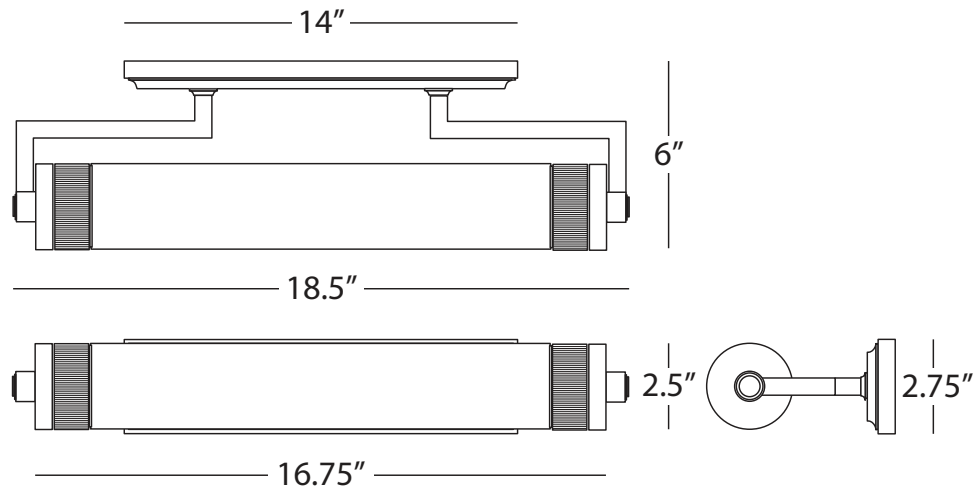
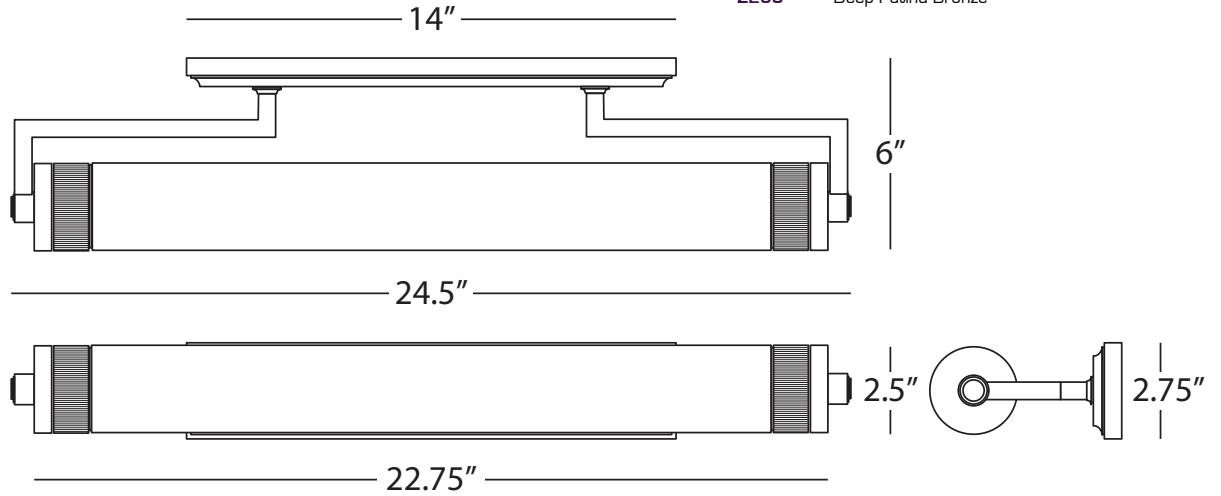

WYATT

S251

18" Picture Light

2 - 25W Max.
 Bulb Type: B, Medium Base
 Switch: On-Off Line Switch
 24" Cord Cover/Direct Wire
 Polished Nickel Finish
 Metal Shade

FINISH OPTIONS:

251 Modern Brass
Z251 Deep Patina Bronze



2433

ZOLTAR

2433

Large Pendant

6 - 25W Max.
Bulb Type: B, Candelabra
Direct Wire
Antique Brass Finish
Clear Glass Shade
Susp. Hardware: 3 pcs. 5/8" x 12"
& 1 pc. 5/8" x 6" Extensions

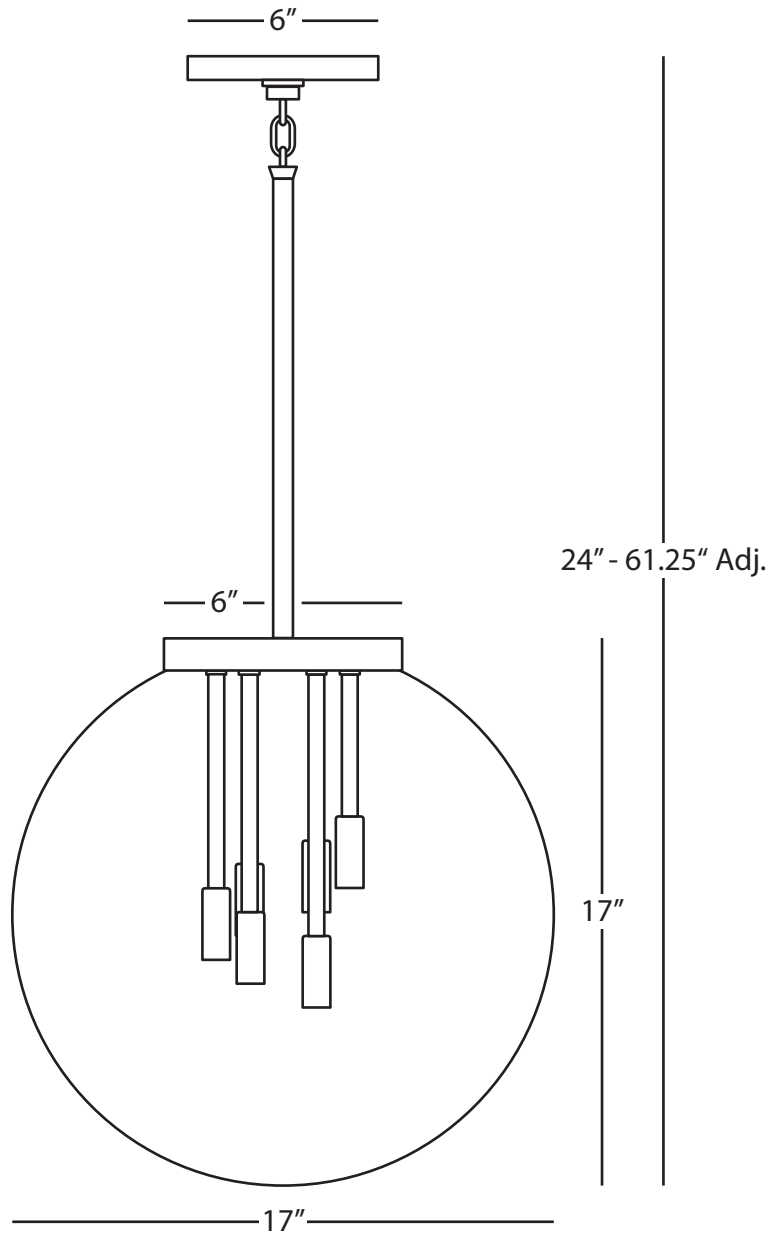

RICO ESPINET



Photograph by Joe Gaffney

Rico Espinet is known for creating striking, poetic environments that combine clean lines and simple forms. Reflecting his training as a sculptor and a preoccupation with personal interiors, Rico's design sensibility is grounded in materials and values that endure. He mixes furnishings, lighting, accessories, industrial objects and fine art to create comfortable yet extraordinary spaces. His popular Robert Abbey Lighting collections feature warm, often atmospheric light inspired by the beauty of everyday objects.



1580W



2068



615



1595



2058

Rico Espinet Arial



615



Z614



S614

Rico Espinet Arial

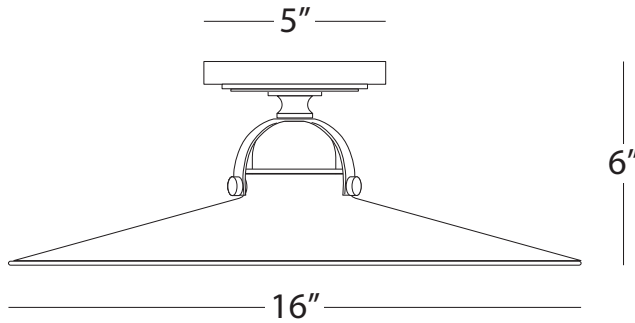

RICO ESPINET ARIAL

S614 Flush Mount

1 - 100W Max.
Bulb Type: A
Direct Wire
Antique Silver Finish
White Glass Shade

FINISH OPTIONS:
614 Warm Brass
Z614 Deep Patina Bronze

RICO ESPINET ARIAL

615 Pendant

1 - 100W Max.
Bulb Type: A
Direct Wire
Warm Brass Finish
White Glass Shade
Susp. Hardware: 3 pcs. 5/8" x 12" &
1 pc. 5/8" x 6" Extensions

FINISH OPTIONS:
S615 Antique Silver
Z615 Deep Patina Bronze

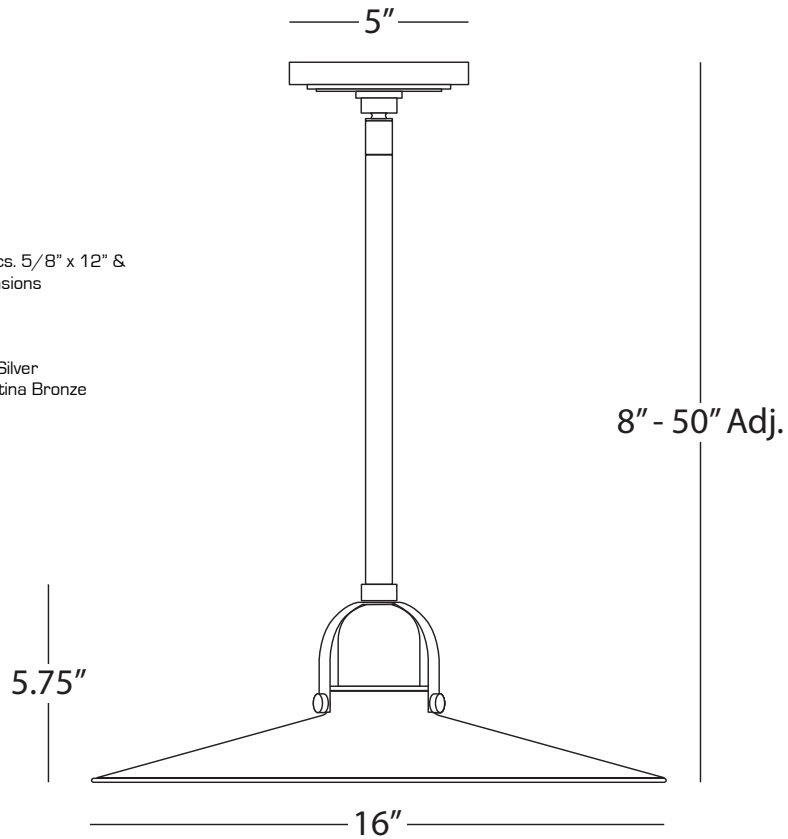

Rico Espinet Bumper



610



D610

Rico Espinet Bumper

RICO ESPINET BUMPER

D610

Pendant

1 - 150W Max.
Bulb Type: G, Medium Base
Direct Wire
Dark Antique Nickel Finish w/
Painted White Shade Interior
Susp. Hardware: 1 pc. 5/8" x 6" &
3 pcs. 5/8" x 12" Extensions

FINISH OPTIONS:

610 Warm Brass
Z610 Deep Patina Bronze

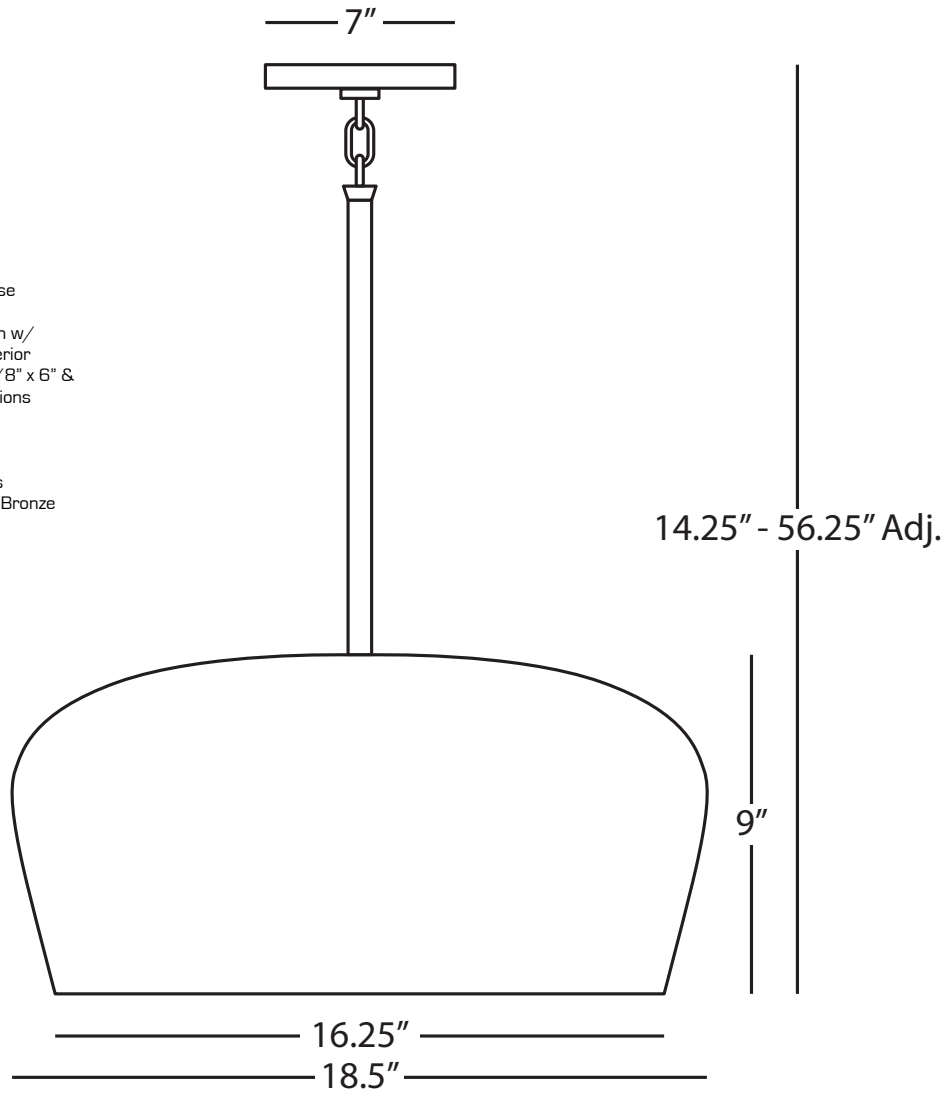

Rico Espinet Buster



2083



2803W



2082



2056W



2075

Rico Espinet Buster

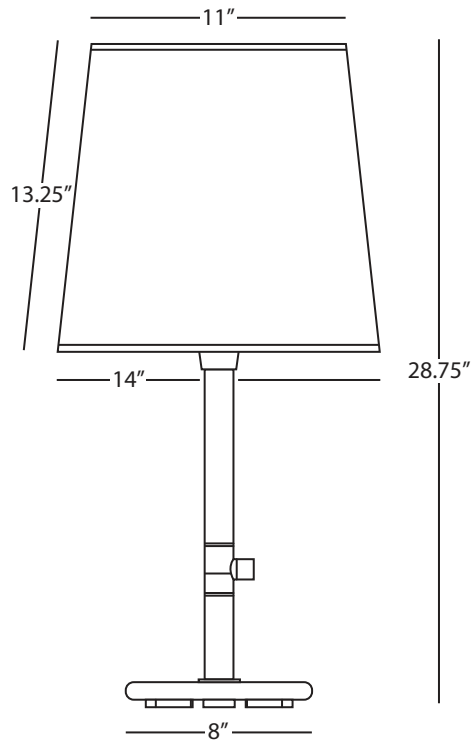

RICO ESPINET BUSTER

2083

Accent Lamp

1 - 150W Max.
Bulb Type: A
Switch: Full Range Dimmer
Deep Patina Bronze Finish
Muslin Claiborne Fabric Shade

FINISH/SHADE OPTIONS:

- 2077** Polished Brass
Smoke Gray Fabric
- 2077W** Polished Brass
Ascot White Fabric
- 2082** Polished Nickel
Taupe Claiborne Fabric
- 2082G** Polished Nickel
Smoke Gray Fabric
- 2082W** Polished Nickel
Fondine Fabric
- 2803** Aged Brass
Smoke Gray Fabric
- 2803W** Aged Brass
Fondine Fabric

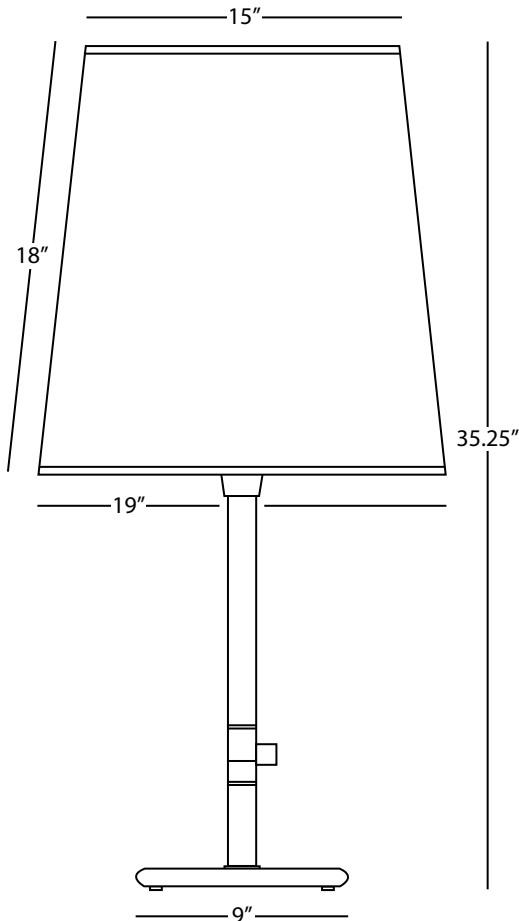

RICO ESPINET BUSTER

2056W

Table Lamp

1 - 200W Max.
Bulb Type: A
Switch: Full Range Dimmer
Polished Nickel Finish
Fondine Fabric Shade

FINISH/SHADE OPTIONS:

- 2056** Polished Nickel
Taupe Claiborne Fabric
- 2056G** Polished Nickel
Smoke Gray Fabric
- 2075** Polished Brass
Smoke Gray Fabric
- 2075W** Polished Brass
Ascot White Fabric
- 2800** Aged Brass
Smoke Gray Fabric
- 2800W** Aged Brass
Fondine Fabric

Rico Espinet Buster



2055G



Z2057



2804W



2079W

Rico Espinet Buster

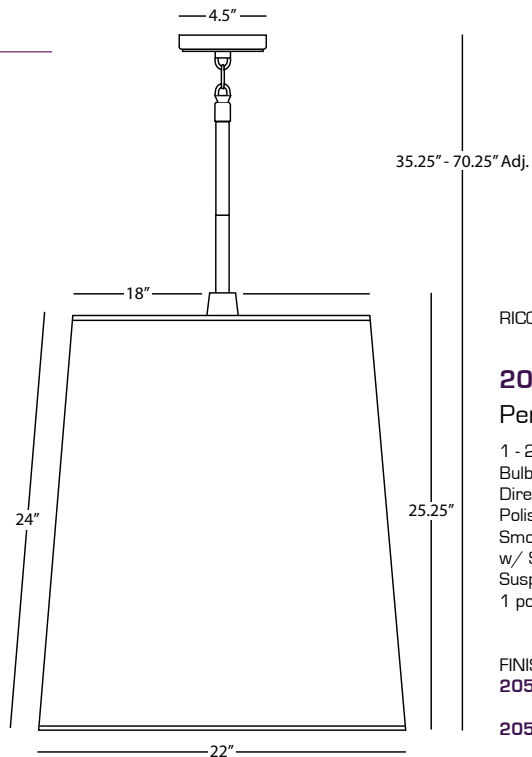

RICO ESPINET BUSTER

2055G

Pendant

1 - 200W Max.
 Bulb Type: A
 Direct Wire
 Polished Nickel Finish
 Smoke Gray Fabric Shade
 w/ Self-Fabric Diffuser
 Susp. Hardware: 3 pcs. 5/8" x 12" &
 1 pc. 5/8" x 6" Extensions

FINISH/SHADE OPTIONS:

- 2055** Polished Nickel
Taupe Claiborne Fabric
- 2055W** Polished Nickel
Fondine Fabric
- 2079** Polished Brass
Smoke Gray Fabric
- 2079W** Polished Brass
Ascot White Fabric
- 2802** Aged Brass
Smoke Gray Fabric
- 2802W** Aged Brass
Fondine Fabric

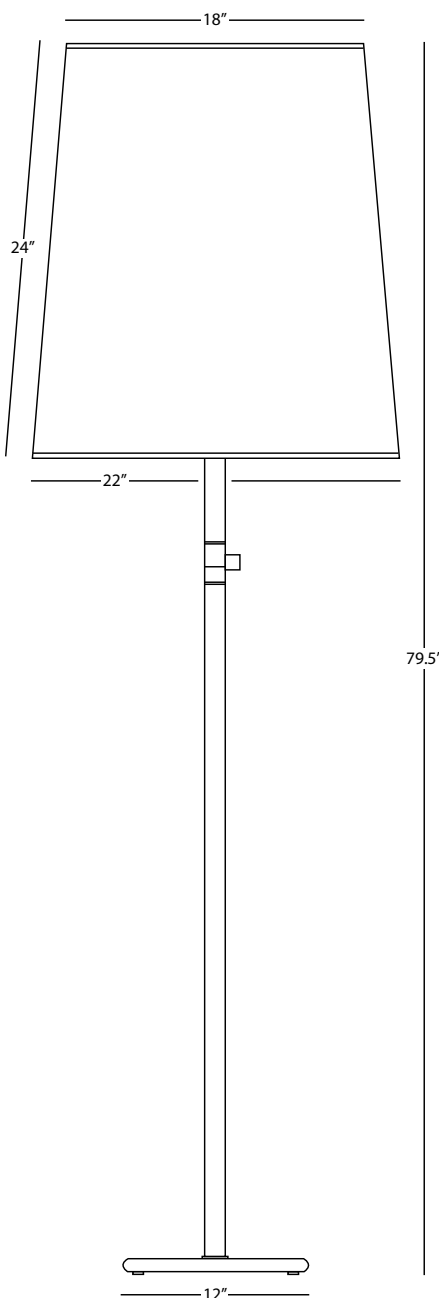

RICO ESPINET BUSTER

Z2057

Floor Lamp

1 - 200W Max.
 Bulb Type: A
 Switch: Full Range Dimmer
 Deep Patina Bronze Finish
 Muslin Claiborne Fabric Shade

FINISH/SHADE OPTIONS:

- 2057** Polished Nickel
Taupe Claiborne Fabric
- 2057G** Polished Nickel
Smoke Gray Fabric
- 2057W** Polished Nickel
Fondine Fabric
- 2801** Aged Brass
Smoke Gray Fabric
- 2801W** Aged Brass
Fondine Fabric

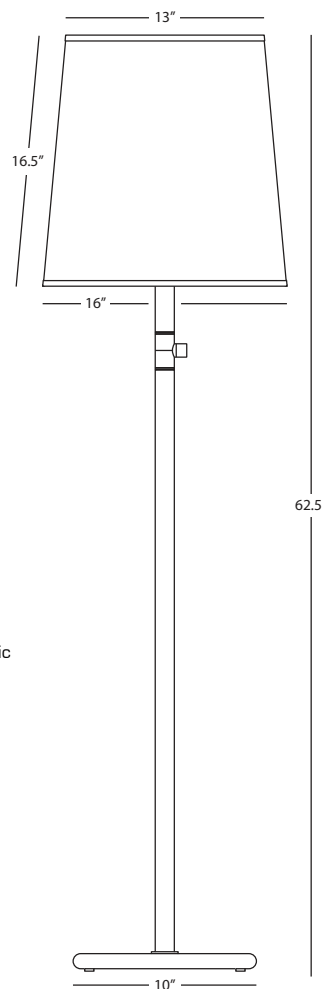

RICO ESPINET BUSTER

2804W

Chica Floor Lamp

1 - 150W Max.
 Bulb Type: A
 Switch: Full Range Dimmer
 Aged Brass Finish
 Fondine Fabric Shade

FINISH/SHADE OPTIONS:

- 2080** Polished Nickel
Taupe Claiborne Fabric
- 2080G** Polished Nickel
Smoke Gray Fabric
- 2080W** Polished Nickel
Fondine Fabric
- 2081** Deep Patina Bronze
Muslin Claiborne
- 2804** Aged Brass
Smoke Gray Fabric

Rico Espinet Candelaria



Z2091



Z2099

Rico Espinet Candelaria

RICO ESPINET CANDELARIA

Z2099

2-Tier Chandelier

30 - 40W Max.
Bulb Type: A
Direct Wire Only
Deep Patina Bronze Finish
Susp. Hardware: 3 pcs. 5/8" x 12"
& 1 pc. 5/8" x 6" Extensions

Photographed with Historical Bulbs
SOLD SEPARATELY
(BUL30 See Page 225)

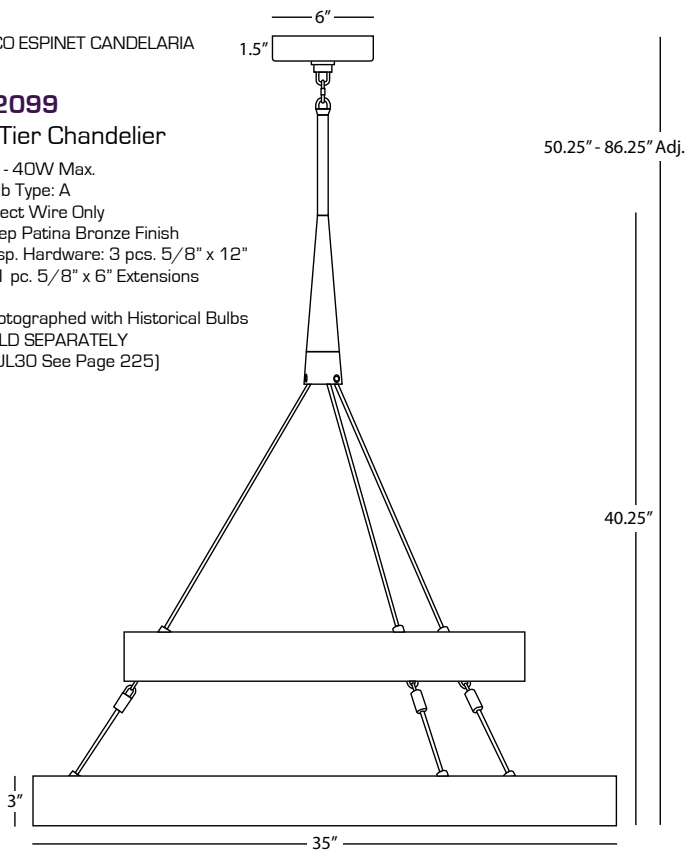

RICO ESPINET CANDELARIA

Z2091

Large Chandelier

18 - 40W Max.
Bulb Type: A
Direct Wire Only
Deep Patina Bronze Finish
Susp. Hardware: 3 pcs. 5/8" x 12"
& 1 pc. 5/8" x 6" Extensions

Photographed with Historical Bulbs
SOLD SEPARATELY
(BUL18 See Page 225)

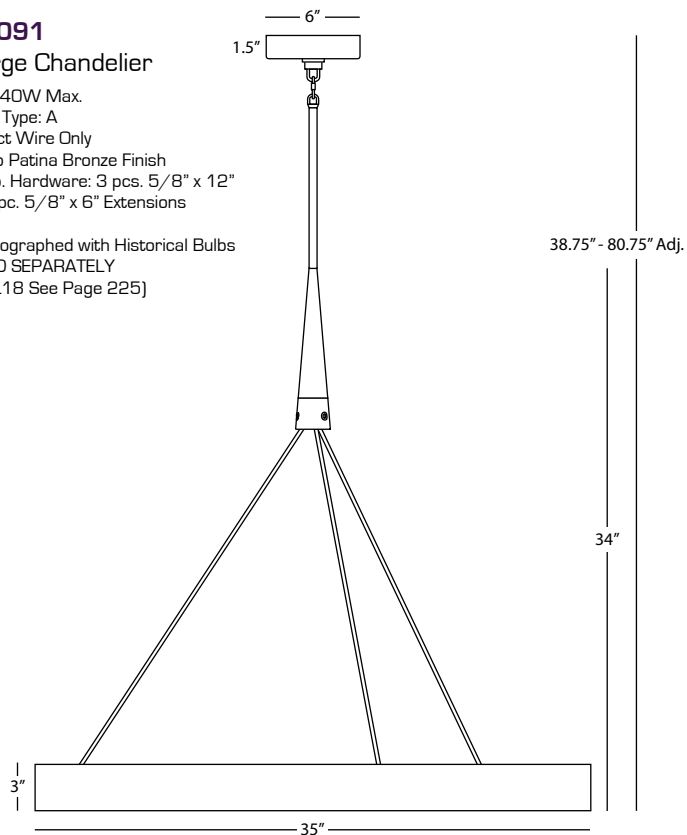

Rico Espinet Lua Vessel



1595

Rico Espinet Lua Vessel

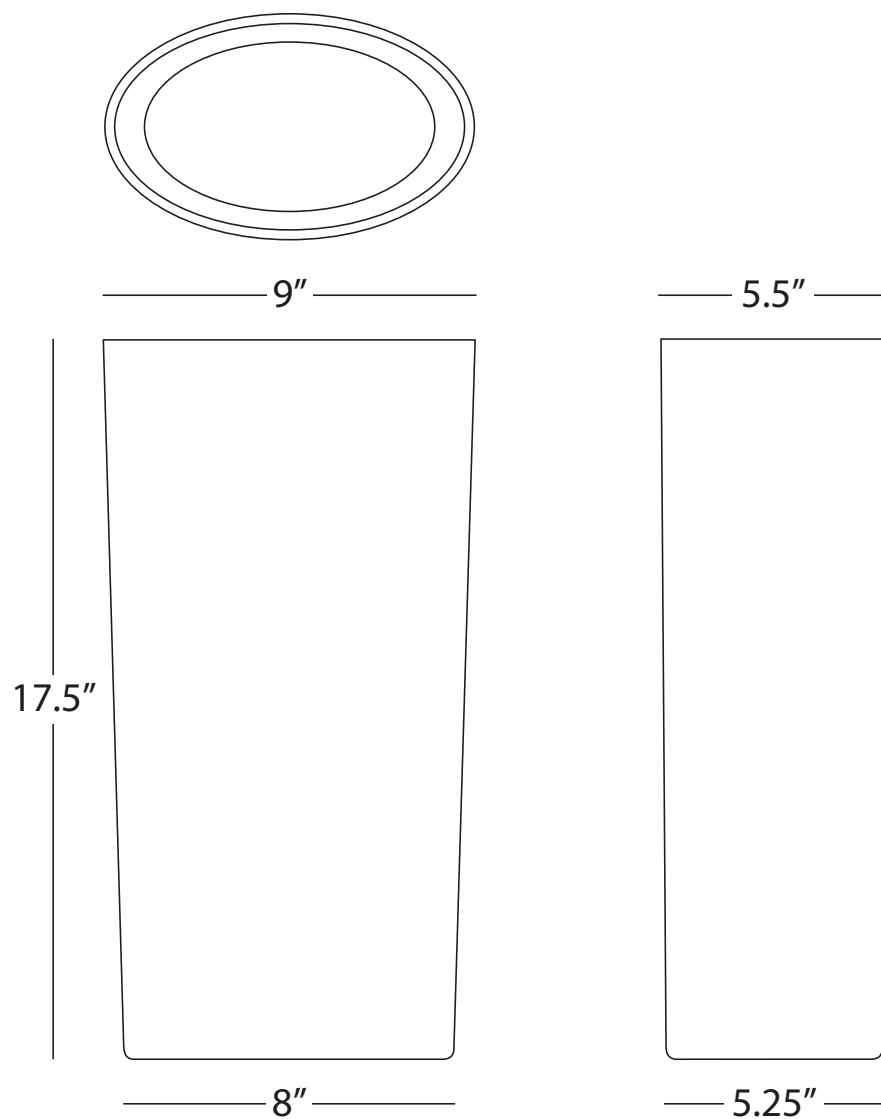

RICO ESPINET LUA VESSEL

1595

Accent Torchiere

1 - 150W Max.

Bulb Type: A

Switch: Hi-Lo Line Switch

Oval White Cased Glass



1591

Rico Espinet Marina

RICO ESPINET MARINA

1591

Table Torchiera

1 - 60W Max.

Bulb Type: T10 Tubular

Switch: Full Range Line Dimmer

Frosted White Cased Glass

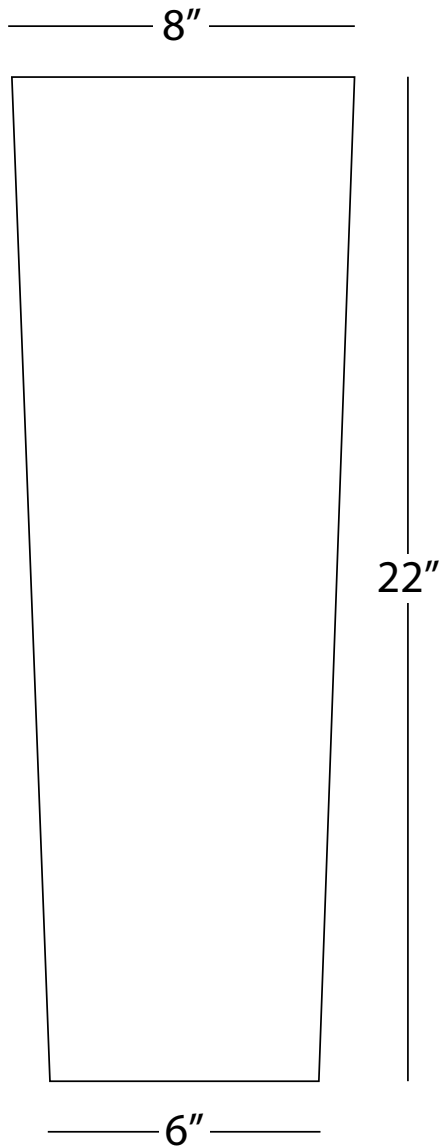



B2097

B2098

Rico Espinet Miles

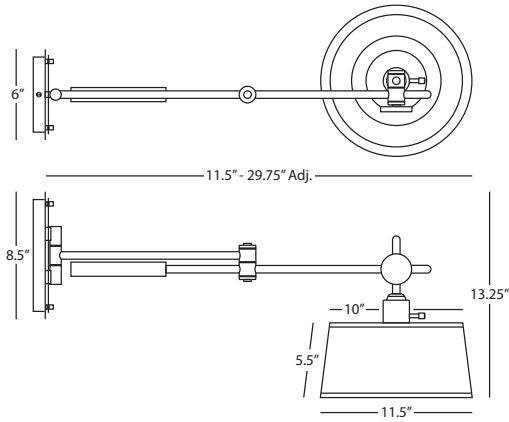

RICO ESPINET MILES

B2098 Wall Mounted Boom Lamp

1 - 100W Max.
Bulb Type: A
Switch: Hi-Lo Dimming
24" Cord Cover / Direct Wire
Brushed Nickel Finish
Concrete Painted Finish over Iron Base
Open Weave White Linen Shade w/
Self-Fabric Diffuser

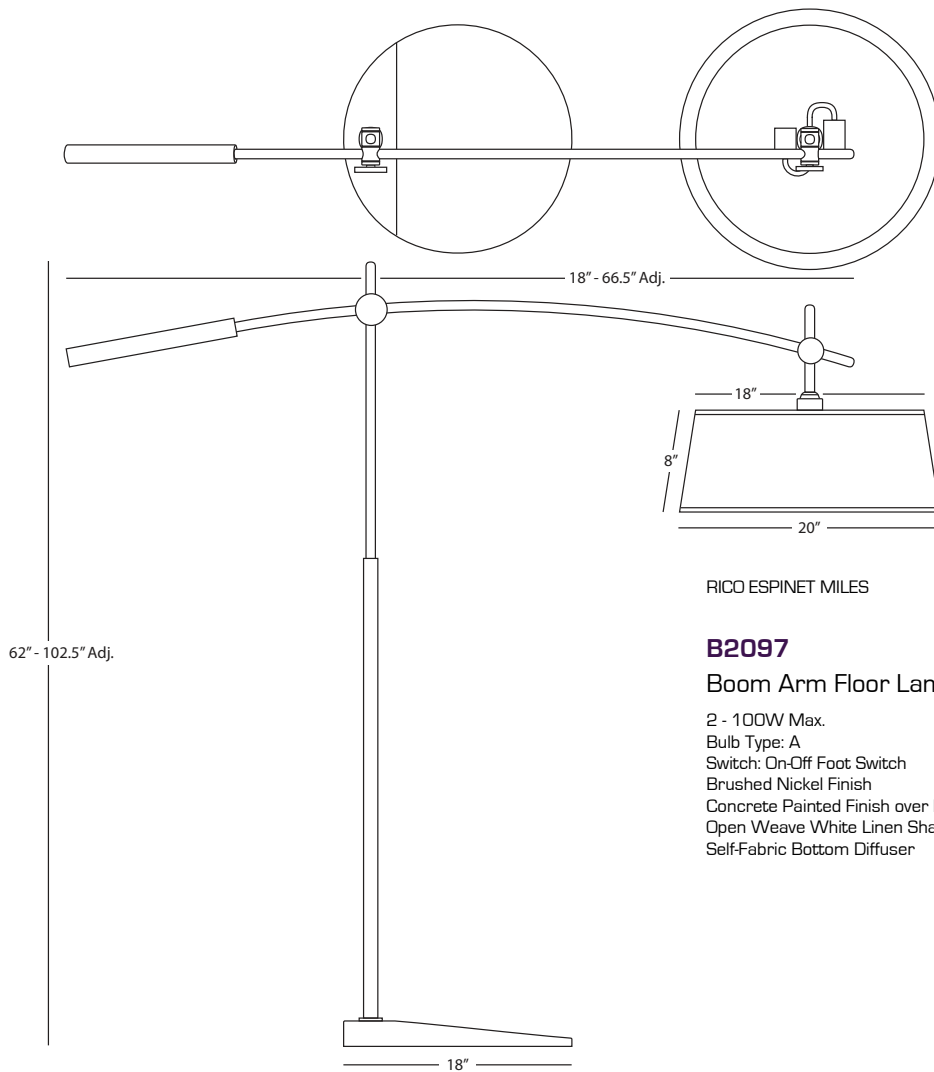

RICO ESPINET MILES

B2097 Boom Arm Floor Lamp

2 - 100W Max.
Bulb Type: A
Switch: On-Off Foot Switch
Brushed Nickel Finish
Concrete Painted Finish over Iron Base
Open Weave White Linen Shade w/
Self-Fabric Bottom Diffuser

Rico Espinet Nina



Rico Espinet Nina

[Click photo above to watch Rico Espinet Nina Floor Lamp Video](#)

Designed by Rico Espinet, our Nina collection features a clean-cut design and inviting illumination provided by a frosted glass shade. Nina is perfect for creating a sophisticated atmosphere in your contemporary space.

- Aged Brass Rico Espinet Nina Torchiere With Frosted White Cased Glass Shade

Rico Espinet Nina



Rico Espinet Nina

[Click photo above to watch Rico Espinet Nina Table Lamp Video](#)

Designed by Rico Espinet, our Nina collection features a clean-cut design and inviting illumination provided by a frosted glass shade. Nina is perfect for creating a sophisticated atmosphere in your contemporary space.

- Aged Brass Rico Espinet Nina Torchiere With Frosted White Cased Glass Shade

Rico Espinet Nina



Z2068



Z2058



2043



2069

Rico Espinet Nina

RICO ESPINET NINA

2043 Flush Mount

1 - 100W Max.
Bulb Type: A
Direct Wire Only
Polished Nickel Finish
Frosted White Cased Glass Shade

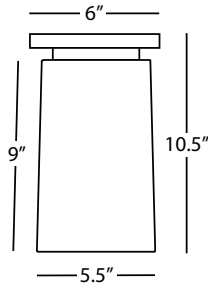

FINISH OPTION:

Z2043 Deep Patina Bronze

RICO ESPINET NINA

Z2058 Corta Flush Mount

1 - 60W Max.
Bulb Type: B11 Torpedo
Direct Wire Only
Deep Patina Bronze Finish
Frosted White Cased Glass Shade

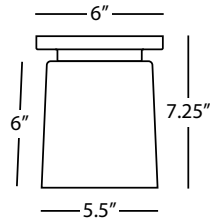

FINISH OPTION:

2058 Polished Nickel

RICO ESPINET NINA

2069 Table Torchiera

1 - 150W Max.
Bulb Type: A
Switch: Full Range Dimmer
Polished Nickel Finish
White Frosted Cased Glass Shade

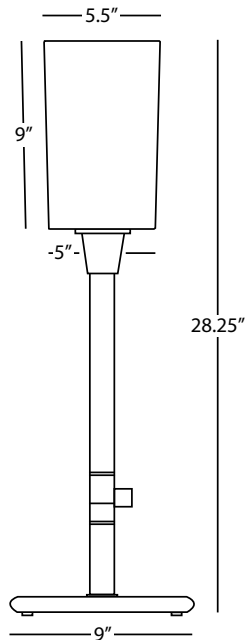

RICO ESPINET NINA

Z2068 Floor Torchiera

1 - 150W Max.
Bulb Type: A
Switch: Full Range Dimmer
Deep Patina Bronze Finish
White Frosted Cased Glass Shade

FINISH OPTION:

2068 Polished Nickel

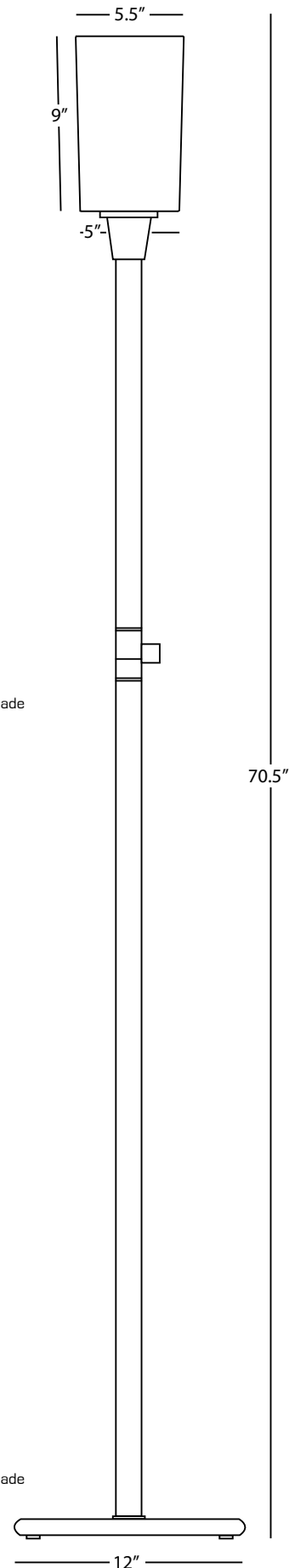

Rico Espinet Nina



B2068



B2069

Rico Espinet Nina

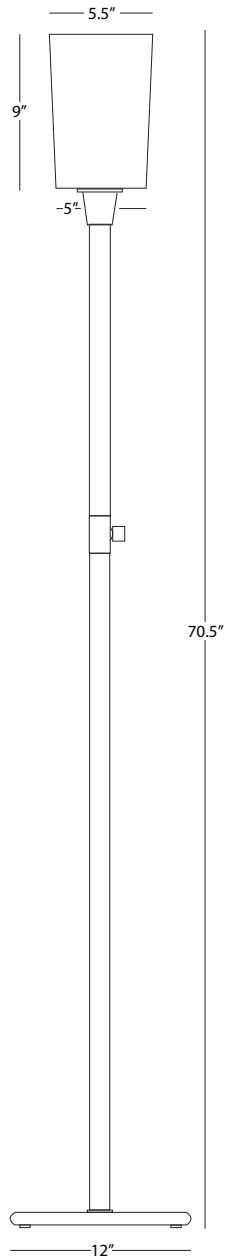

Rico Espinet Nina

B2068

Floor Torchiera

1 - 150W Max.
Bulb Type: A
Switch: Full Range Dimmer
Aged Brass Finish
Frosted White Cased Glass Shade

Finish Options

2068 Polished Nickel
Z2068 Deep Patina Bronze

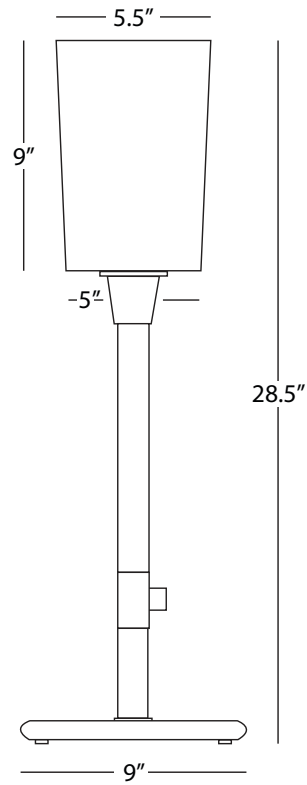

Rico Espinet Nina

B2069

Table Torchiera

1 - 150W Max.
Bulb Type: A
Switch: Full Range Dimmer
Aged Brass Finish
Frosted White Cased Glass Shade

Finish Options

2069 Polished Nickel

Rico Espinet Olinda



1580W



1581B



1578B



1578W

Rico Espinet Olinda

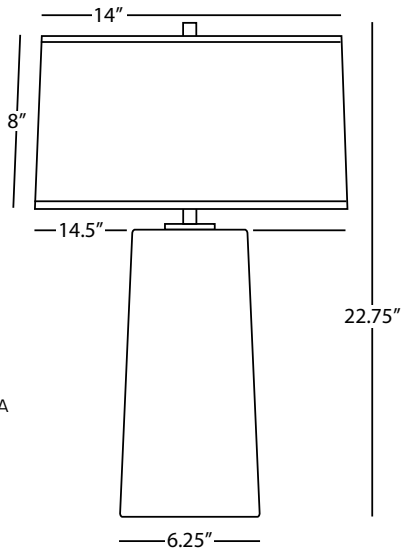

RICO ESPINET OLINDA

1580W Accent Lamp

1 - 100W Max
Bulb Type: A
1 - 7.5W Max. for Night Light Feature
Bulb Type: 7C7 Candelabra
Switch: 4-Way
Frosted White Cased Glass Base w/
Night Light
White Organza Fabric Shade w/
Self-Fabric Top Diffuser

SHADE OPTION:
1580B Black Organza

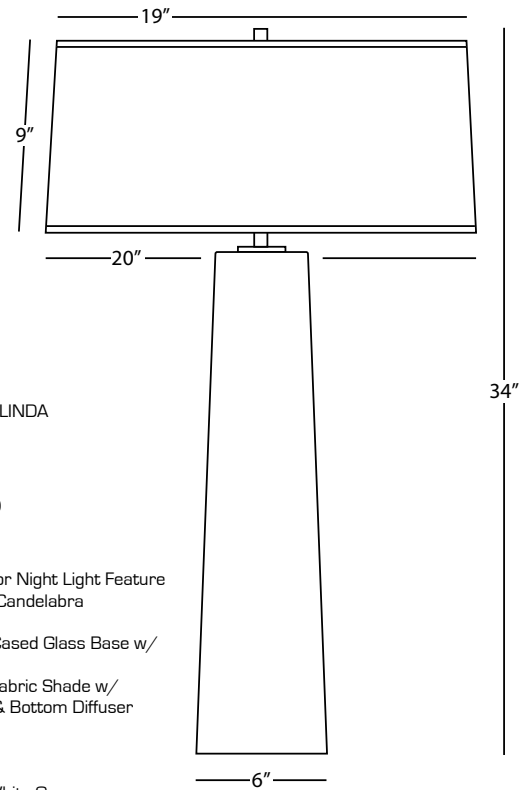

RICO ESPINET OLINDA

1578B Table Lamp

1 - 100W Max
Bulb Type: A
1 - 7.5W Max. for Night Light Feature
Bulb Type: 7C7 Candelabra
Switch: 4-Way
Frosted White Cased Glass Base w/
Night Light
Black Organza Fabric Shade w/
Self-Fabric Top & Bottom Diffuser

SHADE OPTION:
1578W White Organza

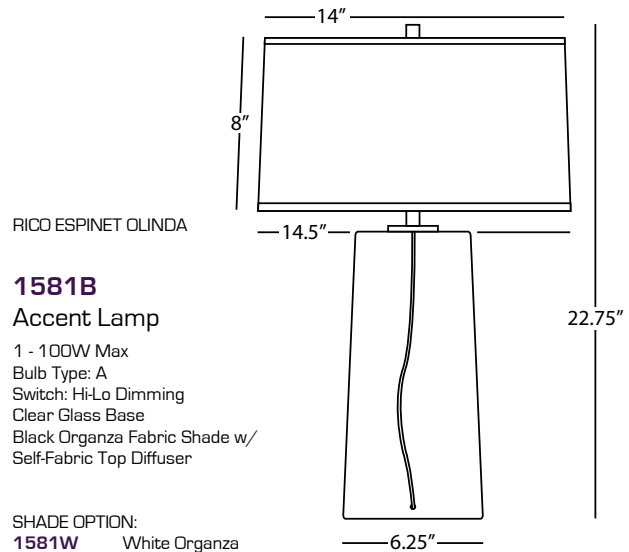

RICO ESPINET OLINDA

1581B Accent Lamp

1 - 100W Max
Bulb Type: A
Switch: Hi-Lo Dimming
Clear Glass Base
Black Organza Fabric Shade w/
Self-Fabric Top Diffuser

SHADE OPTION:
1581W White Organza

Rico Espinet Ovo



Rico Espinet Ovo

[Click photo above to watch Rico Espinet Ovo Floor Lamp Video](#)

Ovo, designed by Rico Espinet for Robert Abbey, features a simple and streamlined design highlighted by a unique, oval, frosted glass shade. This collection radiates brilliant but pleasantly diffused light that will illuminate your modern space perfectly. - Aged Brass Rico Espinet Ovo Torchiere With Frosted White Cased Glass Shade

Rico Espinet Ovo



Rico Espinet Ovo

[Click photo above to watch Rico Espinet Ovo Table Lamp Video](#)

Designed by Rico Espinet for Robert Abbey, Ovo features a simple and streamlined design highlighted by a unique, oval, frosted glass shade. This collection radiates pleasantly diffused light that will illuminate your modern space perfectly.

- Aged Brass Finish Rico Espinet Ovo Table Lamp With Frosted White Cased Glass Shade

Rico Espinet Ovo



Z2045



2044

Rico Espinet Ovo

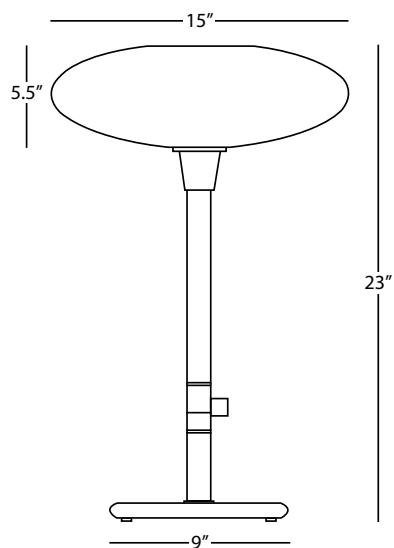

RICO ESPINET OVO

2044

Table Lamp

1 - 150W Max.
Bulb Type: A
Switch: Full Range Dimmer
Polished Nickel Finish
Frosted White Cased Glass Shade

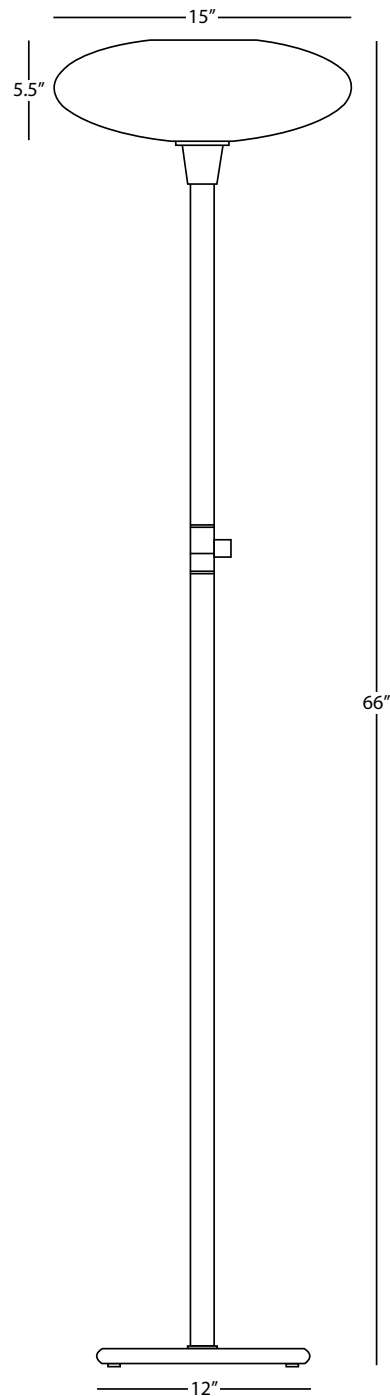

RICO ESPINET OVO

Z2045

Floor Torchiere

1 - 150W Max.
Bulb Type: A
Switch: Full Range Dimmer
Deep Patina Bronze
Frosted White Cased Glass Shade

FINISH OPTION:

2045 Polished Nickel

Rico Espinet Ovo



B2045



B2044

Rico Espinet Ovo

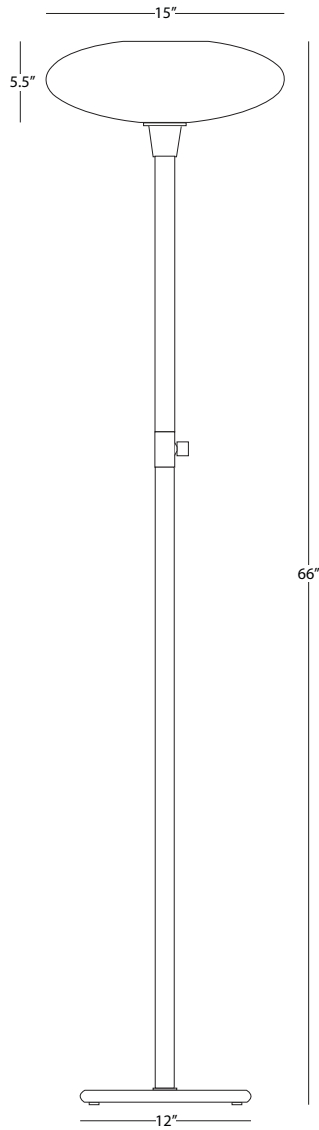

Rico Espinet Ovo

B2045

Floor Torchiere

1 - 150W Max.
Bulb Type: A
Switch: Full Range Dimmer
Aged Brass Finish
Frosted White Cased Glass Shade

Finish Options

2045 Polished Nickel
Z2045 Deep Patina Bronze

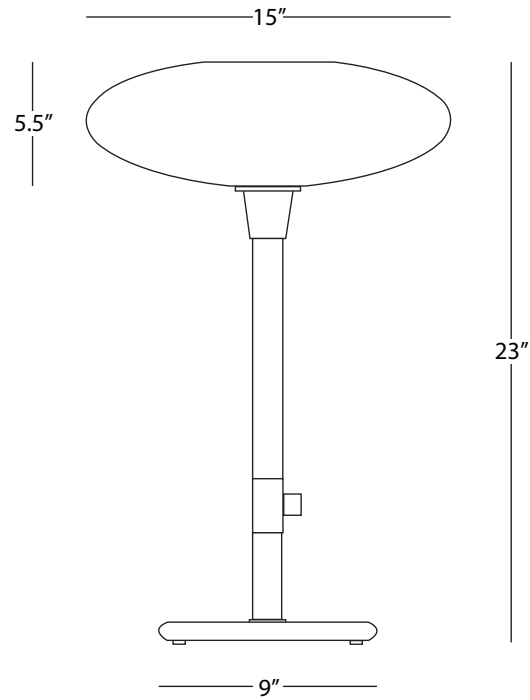

Rico Espinet Ovo

B2044

Table Torchiere

1 - 150W Max.
Bulb Type: A
Switch: Full Range Dimmer
Aged Brass Finish
Frosted White Cased Glass Shade

Finish Options

2044 Polished Nickel

Rico Espinet Ovo



Rico Espinet Ovo



[Click photo above to watch Arthur video](#)

Designed by Rico Espinet for Robert Abbey, Ovo features a simple and streamlined design highlighted by a unique, oval, frosted glass shade.

Rico Espinet Ovo



2039



S2039



Z2039

Rico Espinet Ovo

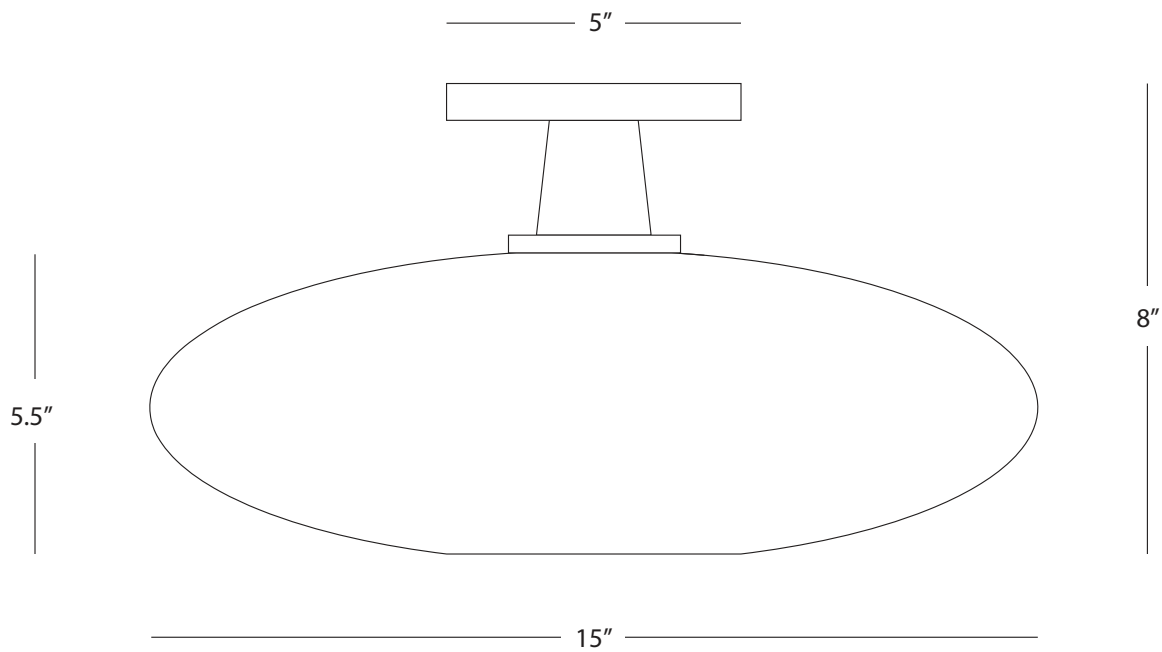

RICO ESPINET OVO

2039

Flush Mount

1 - 100W Max.
Bulb Type: A
Direct Wire Only
Aged Brass Finish
Frosted Cased White Glass Shade
UL Rated Damp Locations

FINISH OPTIONS:

S2039 Polished Nickel
Z2039 Deep Patina Bronze

Rico Espinet Racer



Rico Espinet Racer

[Click photo above to watch Rico Espinet Racer Wall Sconce Video](#)

Streamlined and modern, our Rico Espinet Racer collection enhances any space. Racer has a dynamic design featuring a sweeping arm ending in an adjustable shade to suit your lighting preference.

Rico Espinet Racer



Rico Espinet Racer

[Click photo above to watch Rico Espinet Racer Wall Sconce Video](#)

Streamlined and modern, our Rico Espinet Racer collection enhances any space. Racer has a dynamic design featuring a sweeping arm ending in an adjustable shade to suit your lighting preference.



1522



1524



1528

Rico Espinet Racer

RICO ESPINET RACER

1522

Chandelier

5 - 100W Max.
 Bulb Type: A
 Direct Wire
 Modern Brass Finish
 Matte Black Adjustable Shades
 Susp. Hardware: 1 pc. 5/8" x 6" & 3 pcs.
 5/8" x 12" Extensions

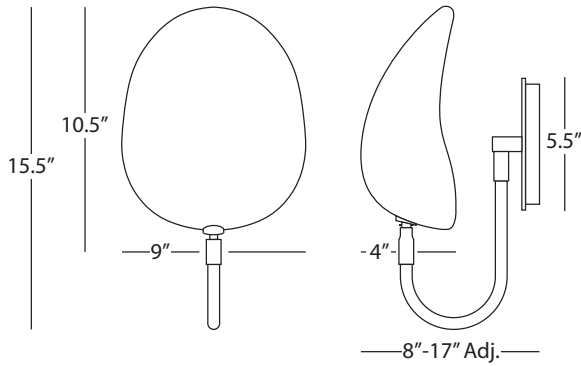
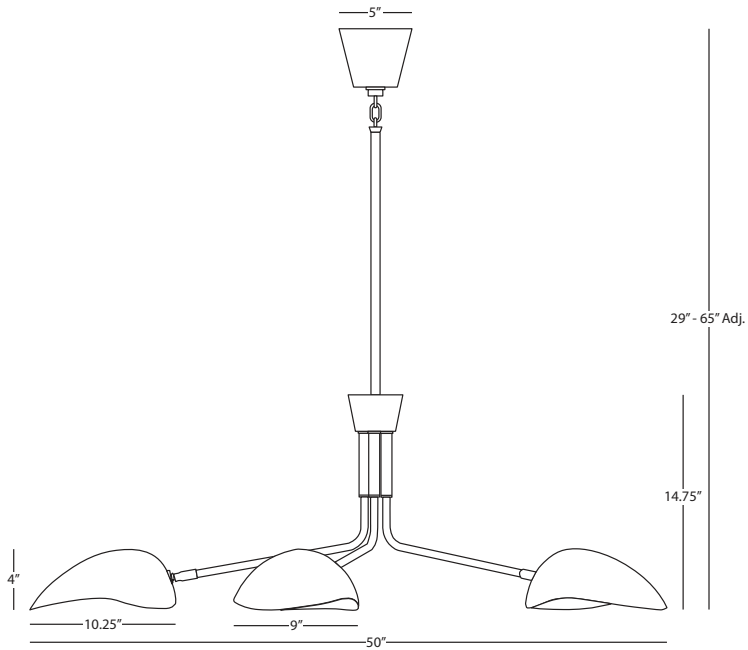

Rico Espinet Racer

1524

Adjustable Wall Sconce

1 - 60W Max.
 Bulb Type: A
 Switch: On-Off Line Switch
 24" Cord Cover/Direct Wire
 Modern Brass Finish
 Matte Black Adjustable Shade & Accents

Rico Espinet Racer

1528

Adjustable Double Wall Sconce

2 - 60W Max.
 Bulb Type: A
 Switch: On-Off Line Switch
 24" Cord Cover/Direct Wire
 Modern Brass Finish
 Matte Black Adjustable Shade & Accents

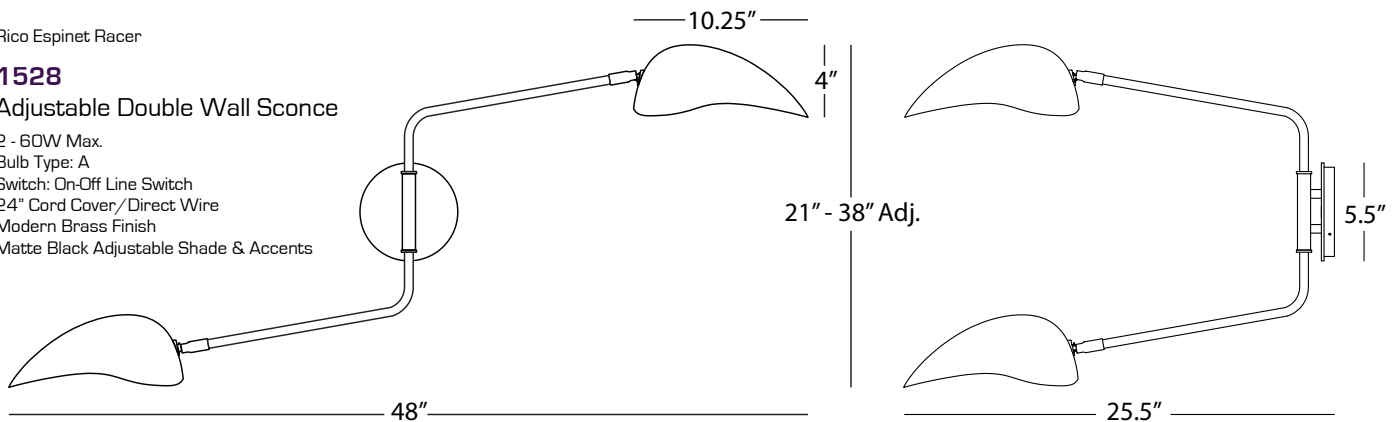



W1522



W1524



W1528

Rico Espinet Racer

Rico Espinet Racer

W1522

Adjustable Wall Sconce

5 - 100W Max.
 Bulb Type: A
 Direct Wire Only
 Modern Brass Finish
 Satin White Adjustable Shade & Accents
 Susp. Hardware: 3 pcs - 5/8" x 12"
 & 1 pc - 5/8" x 6" Extension Rods

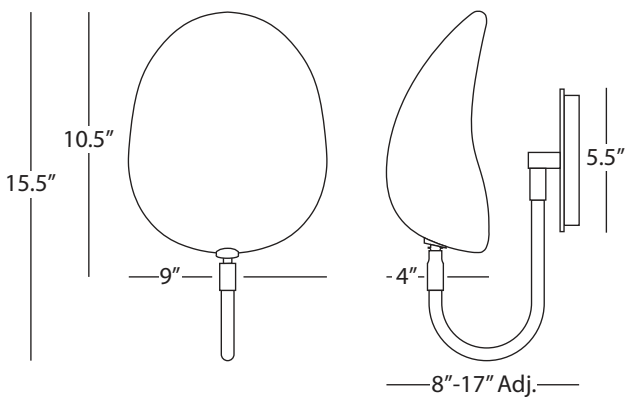
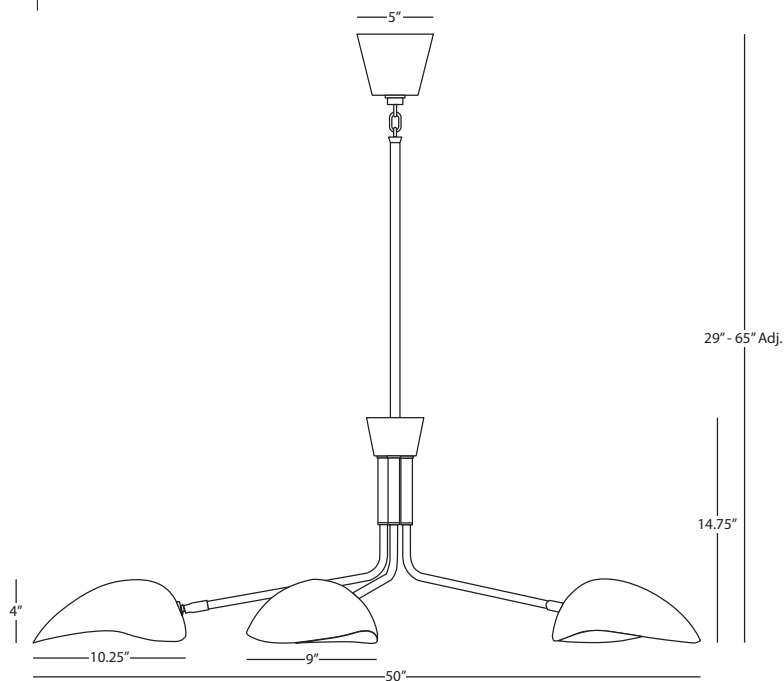

Rico Espinet Racer

W1524

Adjustable Wall Sconce

1 - 60W Max.
 Bulb Type: A
 Switch: On-Off Line Switch
 24" Cord Cover/Direct Wire
 Modern Brass Finish
 Satin White Adjustable Shade & Accents

Rico Espinet Racer

W1528

Adjustable Double Wall Sconce

2 - 60W Max.
 Bulb Type: A
 Switch: On-Off Line Switch
 24" Cord Cover/Direct Wire
 Modern Brass Finish
 Satin White Adjustable Shades & Accents

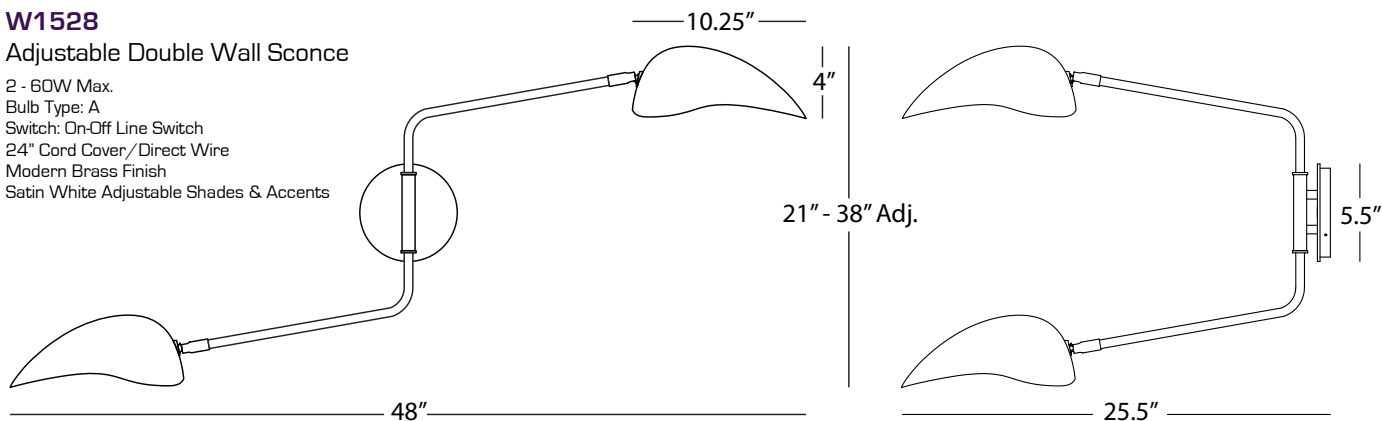

Rico Espinet Scout



S248



248

Rico Espinet Scout

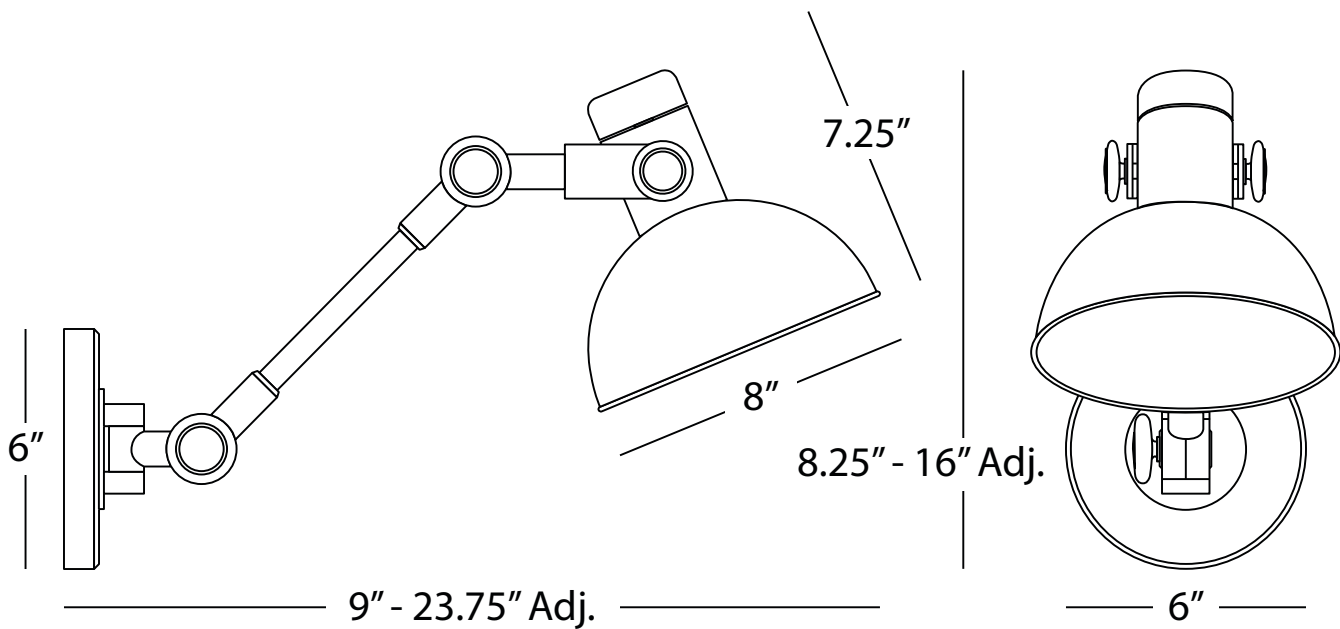

RICO ESPINET SCOUT

248

Adjustable Wall Sconce

1 - 60W Max.
Bulb Type: A
Switch: Hi-Lo Dimming
24" Cord Cover/Direct Wire
Antique Brass Finish
Adjustable Metal Shade

FINISH OPTION:

S248 Polished Nickel

Rico Espinet Shinto



2171

Rico Espinet Shinto

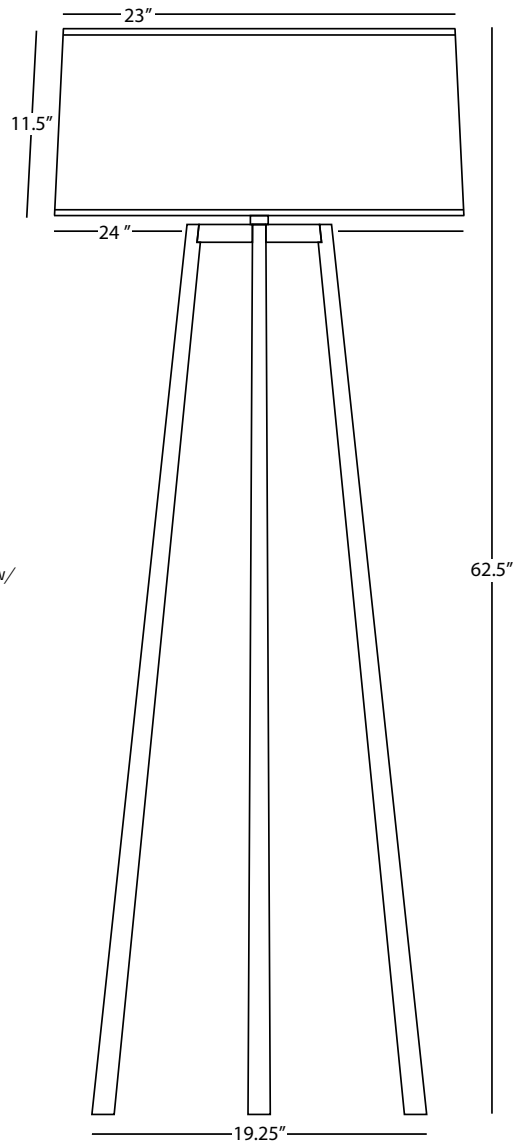
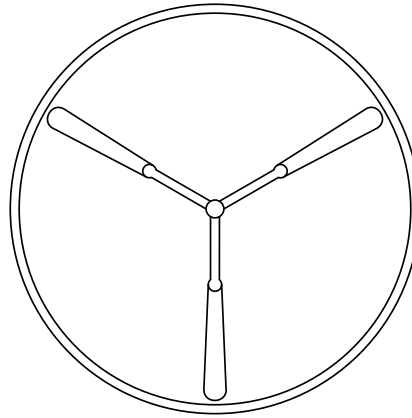

RICO ESPINET SHINTO

2171

Tripod Floor Lamp

1 - 150W Max.

Bulb Type: A

Switch: 3-Way

Wrought Iron Finish

Ascot White Fabric Shade w/

Black Contrast Trim

JONATHAN ADLER



Potter, designer, and author Jonathan Adler launched his namesake brand after leaving his day job to pursue his first love: pottery. In 1993, Barneys bought his collection, and five years later, he opened his first store in Soho.

Today his offerings span furniture, lighting, home décor, and more, plus countless iconic interior projects, and retail locations worldwide, all dedicated to bringing Modern American Glamour to your life.

Jonathan's design work can be found in top restaurants, hotels, and homes around the world.

The Jonathan Adler brand now has retail locations worldwide, a thriving e-commerce site, a full slate of residential and commercial projects, and a wholesale business boasting over 1,000 locations globally.



851B



687

JONATHAN ADLER

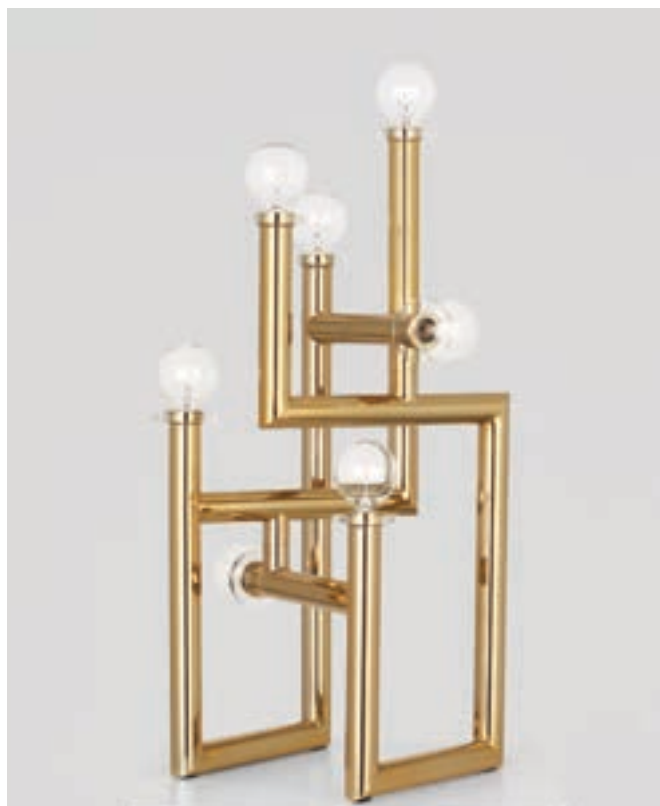

902



S157



676



L911B

Jonathan Adler Bellport



Jonathan Adler Bellport

Click photo above to watch Jonathan Adler Bellport Table Lamp Video

Vintage vibes and a lightweight feel combine to create an impactful design in our Bellport collection by Jonathan Adler Bellport is truly charming with natural caning accents and warm, ambient light.

Jonathan Adler Bellport

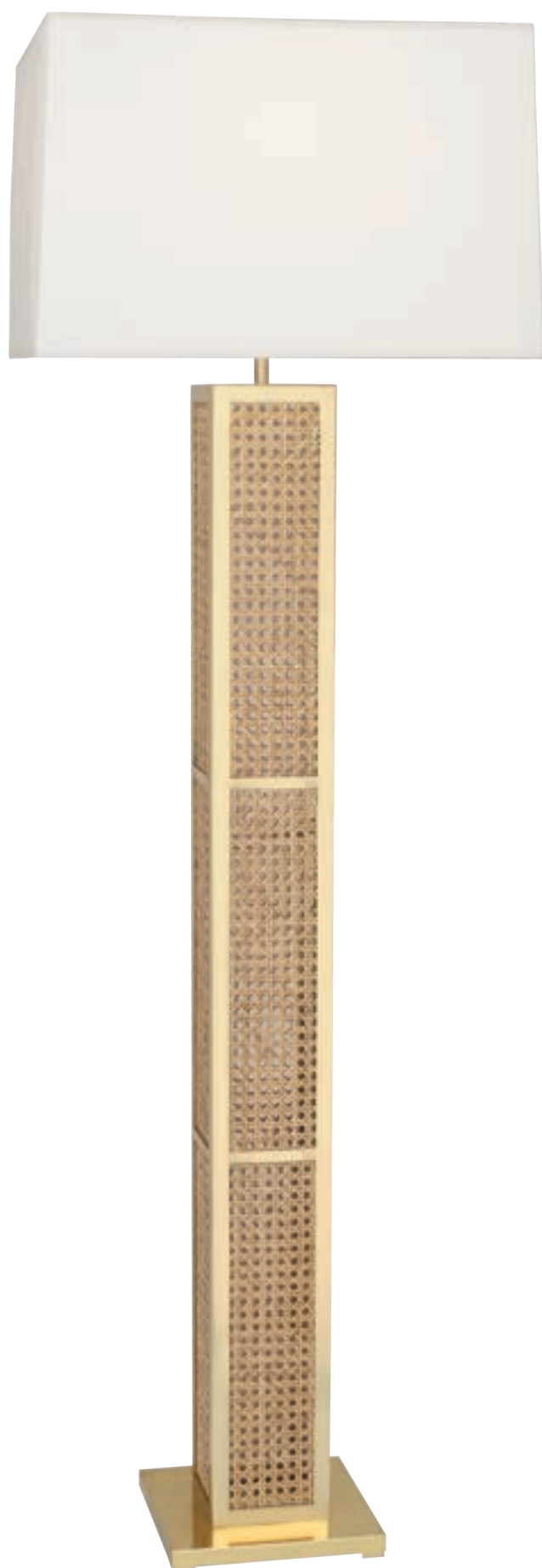

Jonathan Adler Bellport

Click photo above to watch Jonathan Adler Bellport Floor Lamp Video

Vintage vibes and a lightweight feel combine to create an impactful design in our Bellport collection by Jonathan Adler Bellport is truly charming with natural caning accents and warm, ambient light.

Jonathan Adler Bellport



Jonathan Adler Bellport

Click photo above to watch Jonathan Adler Bellport Pendant Video

Vintage vibes and a lightweight feel combine to create an impactful design in our Bellport collection by Jonathan Adler Bellport is truly charming with natural caning accents and warm, ambient light.

Jonathan Adler Bellport



617



616



618

Jonathan Adler Bellport

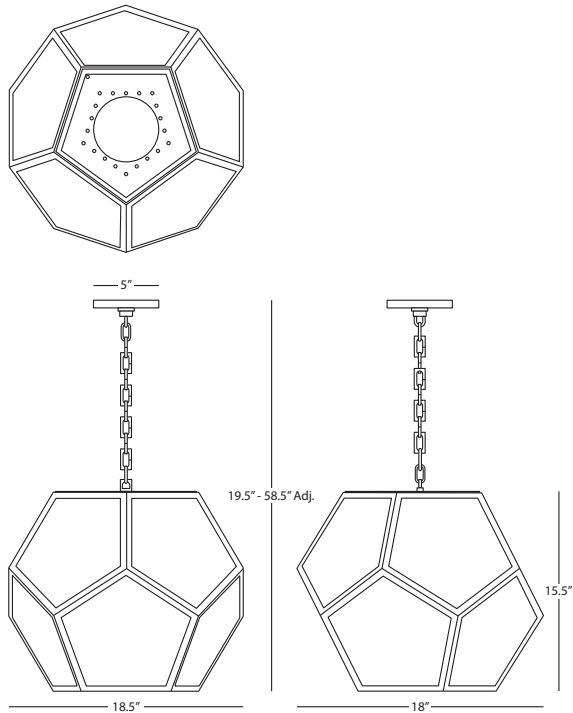

Jonathan Adler Bellport

616

Pendant

3 - 13W Max.
 Bulb Type: LED ONLY
 Direct Wire
 Modern Brass Finish
 Caning Shade Panels (x12)
 Susp. Hardware: 3 Ft. Chain

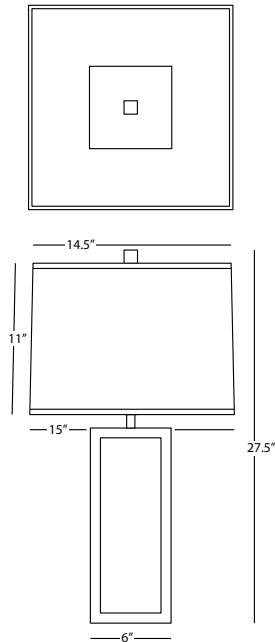

Jonathan Adler Bellport

617

Table Lamp

1 - 150W Max.
 Bulb Type: A
 Switch: Full Range Dimmer
 Modern Brass Finish
 Caning Panels
 Square Fondine Fabric Shade

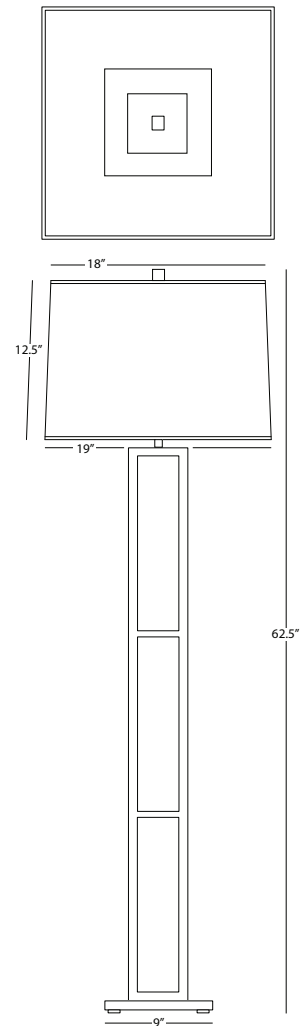

Jonathan Adler Bellport

618

Floor Lamp

1 - 150W Max.
 Bulb Type: A
 Switch: Full Range Dimmer
 Modern Brass Finish
 Caning Panels
 Square Fondine Fabric Shade

Jonathan Adler Bellport



619

Jonathan Adler Bellport

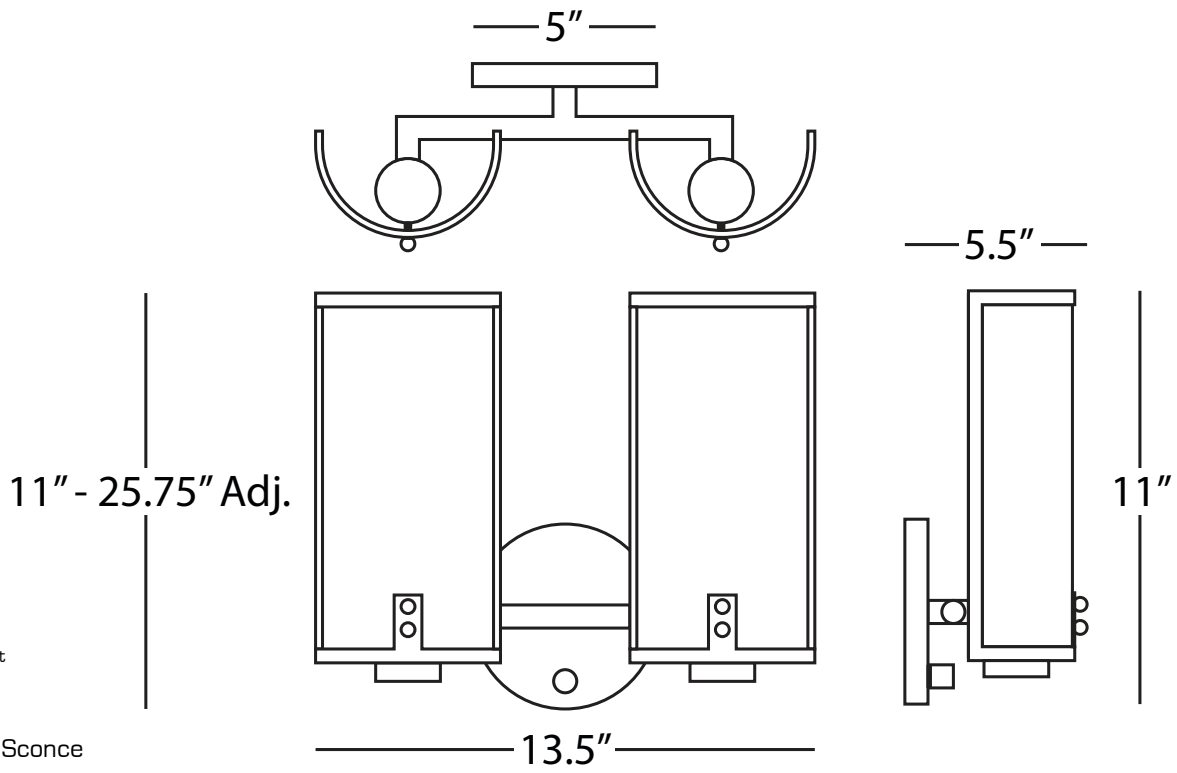

Bellport

619 Wall Sconce

- 2 - 5W Max.
- Bulb Type: LED
- Switch: Full Range Dimmer
- 24" Cord Cover / Direct Wire
- Modern Brass Finish
- Rattan Accents



S475



BL476

Jonathan Adler Biarritz

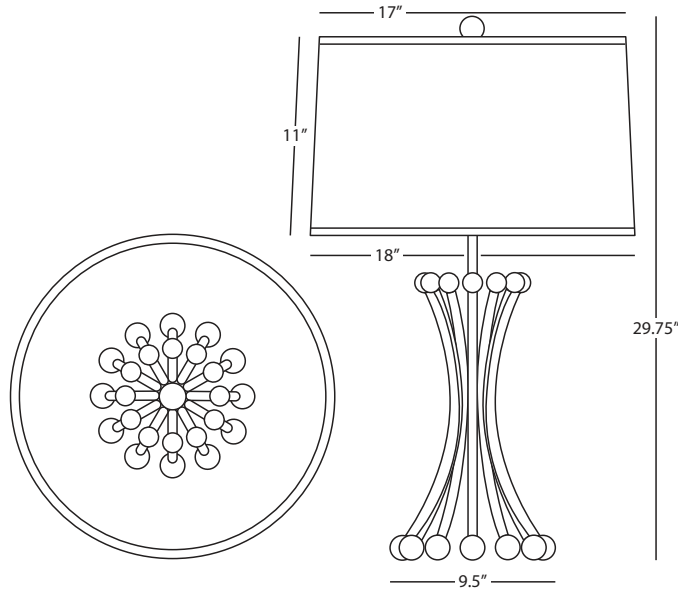

JONATHAN ADLER BIARRITZ

BL475 Table Lamp

1 - 150W Max.
Bulb Type: A
Switch: Full Range Dimmer
Blackened Metal Finish w/
Polished Brass Accents
Ascot White Fabric Shade

FINISH OPTIONS:
475 Polished Brass
S475 Polished Nickel

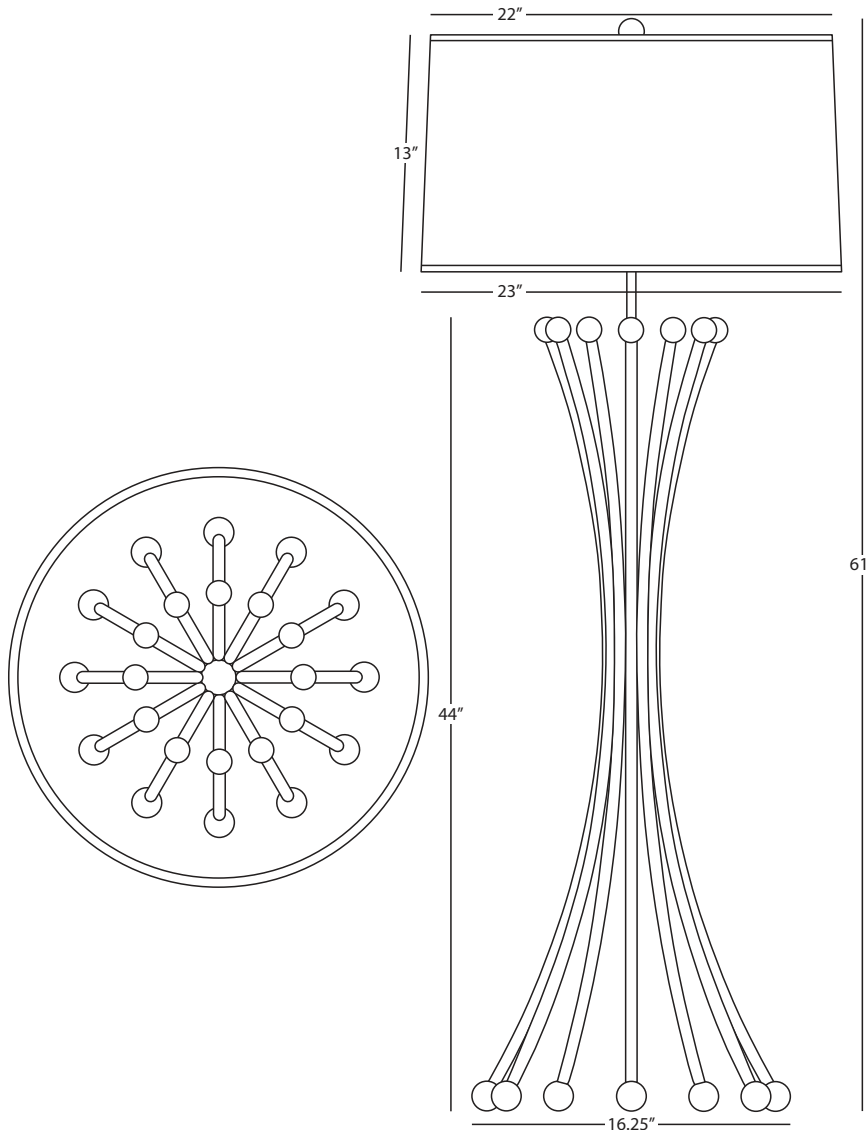

JONATHAN ADLER BIARRITZ

BL476 Floor Lamp

1 - 150W Max.
Bulb Type: A
Switch: Full Range Dimmer
Blackened Metal Finish with
Polished Brass Accents
Ascot White Fabric Shade

Jonathan Adler Bristol



S875



706



S707



707

Jonathan Adler Bristol

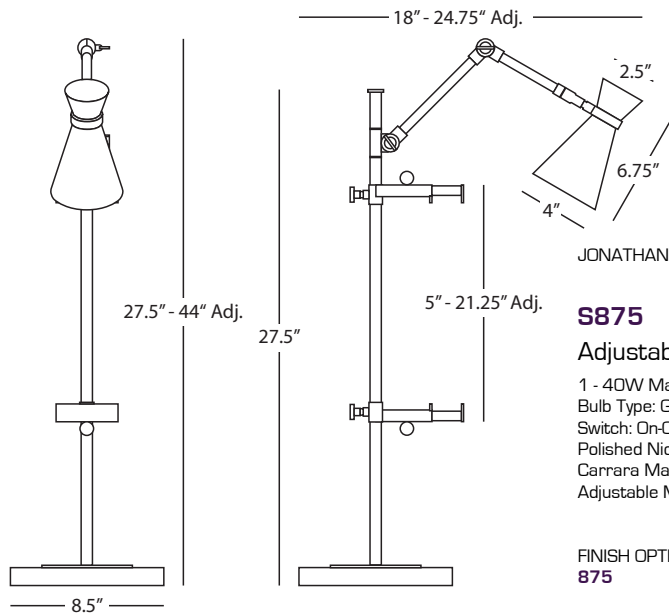

JONATHAN ADLER BRISTOL

S875

Adjustable Table Easel w/ Lamp

1 - 40W Max.
 Bulb Type: G16.5, Candelabra Base
 Switch: On-Off Line Switch
 Polished Nickel Finish
 Carrara Marble Base
 Adjustable Metal Shade

FINISH OPTION:

875 Antique Brass
 Honed Travertine Base

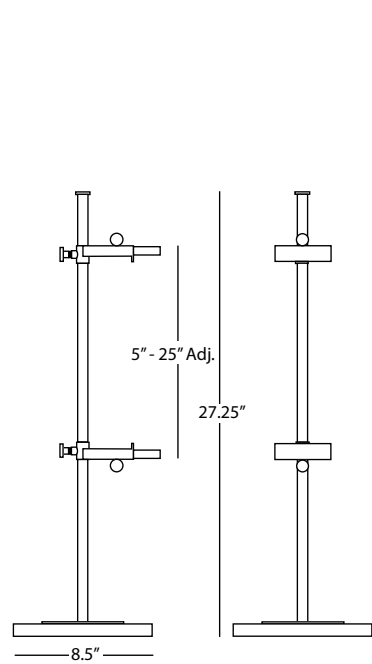

JONATHAN ADLER BRISTOL

707

Adjustable Table Easel

Antique Brass Finish
 Honed Travertine Base

FINISH OPTION:

S707 Polished Nickel
 Carrara Marble Base

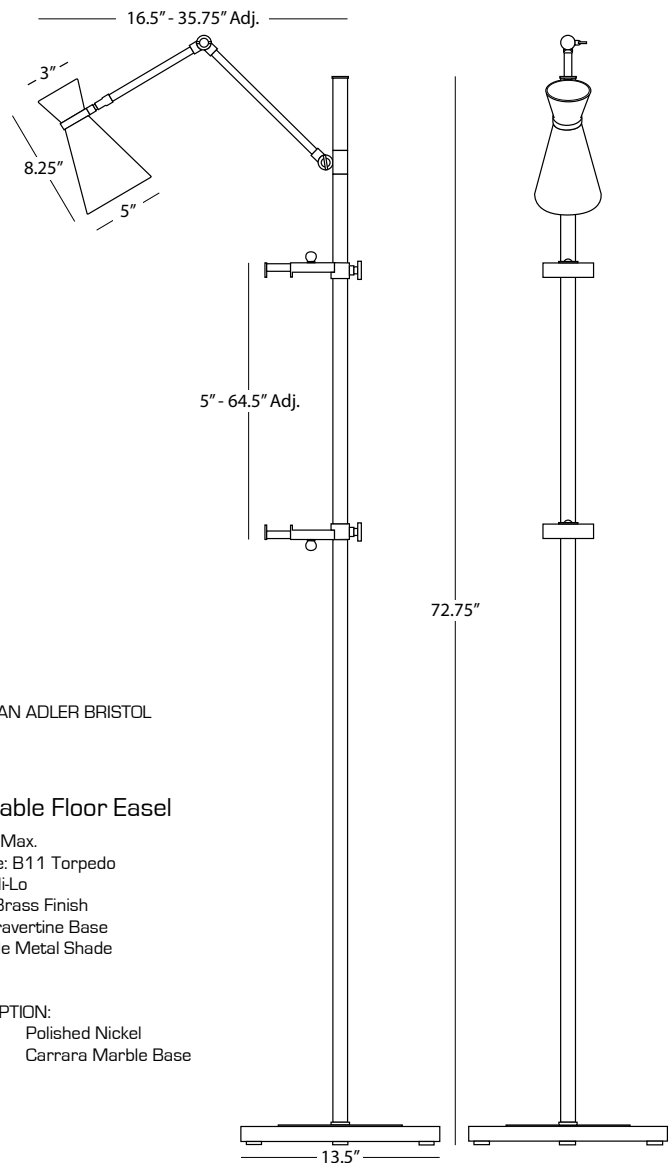

JONATHAN ADLER BRISTOL

706

Adjustable Floor Easel

1 - 60W Max.
 Bulb Type: B11 Torpedo
 Switch: Hi-Lo
 Antique Brass Finish
 Honed Travertine Base
 Adjustable Metal Shade

FINISH OPTION:

S706 Polished Nickel
 Carrara Marble Base

Jonathan Adler Canaan



795X



B796X



796

Jonathan Adler Canaan

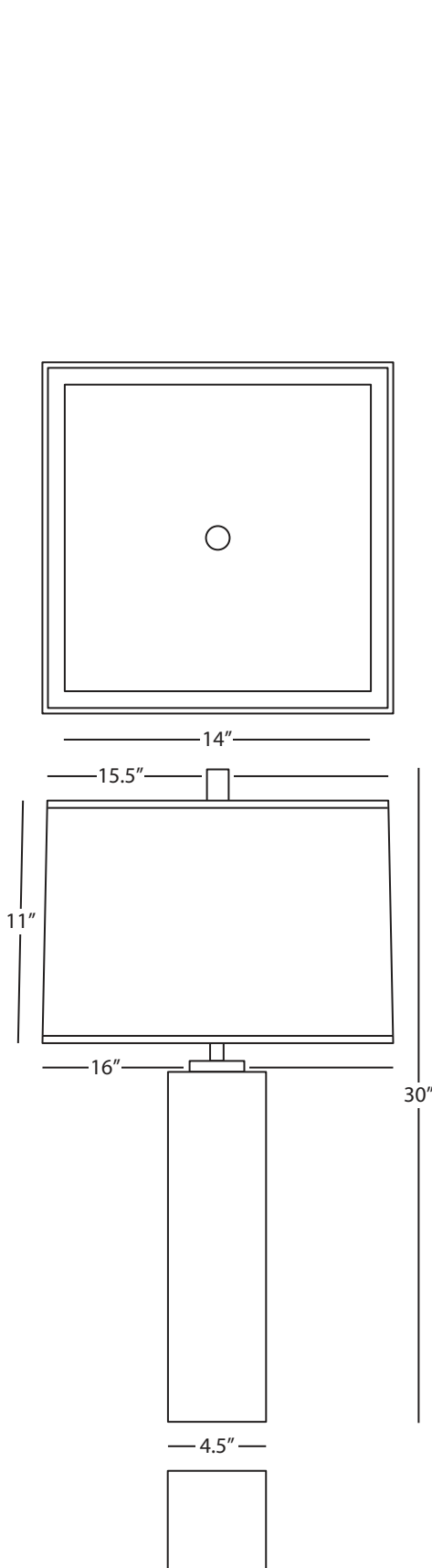

JONATHAN ADLER CANAAN

796 Table Lamp

1 - 150W Max.
Bulb Type: A
Switch: Hi-Lo Dimming
Carrara Marble Base
Antique Brass Accents
Square Oyster Linen Shade w/
Perforated Metal Top Diffuser
Black Fabric Wrapped Cord

FINISH/SHADE OPTIONS:
796X Carrara Marble
Smoke Gray Fabric
Black Marble
B796 White Brussels Linen
B796X Black Marble
Black Opaque Parchment
w/ White Lining

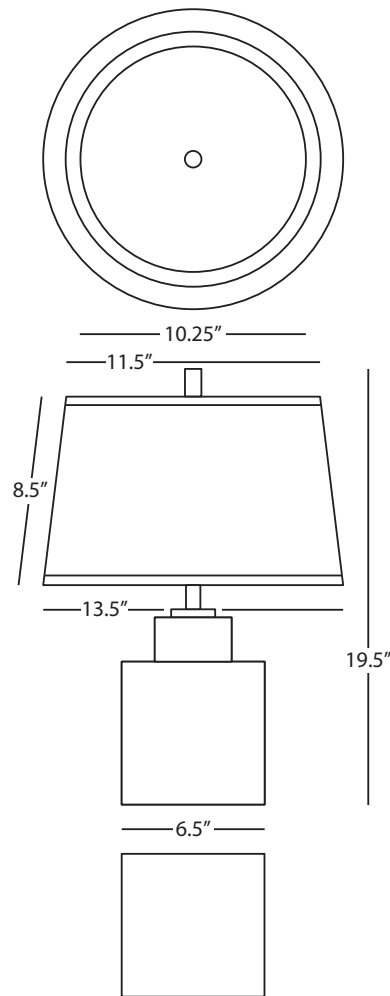

JONATHAN ADLER CANAAN

795X Accent Lamp

1 - 100W Max.
Bulb Type: A
Switch: Hi-Lo Dimming
Carrara Marble Base
Antique Brass Accents
Smoke Gray Fabric Shade w/
Perforated Metal Top Diffuser
Black Fabric Wrapped Cord

SHADE OPTION:
795 Oyster Linen

Jonathan Adler Canaan



680



889



851B

Jonathan Adler Canaan

JONATHAN ADLER CANAAN

889

Shift Table Lamp

1 - 150W Max.
 Bulb Type: A
 Switch: Hi-Lo Dimming
 Carrara and Black Marble Base
 Antique Brass Accents
 Oyster Linen Fabric Shade
 Perforated Metal Top Diffuser
 Black Fabric Wrapped Cord

SHADE OPTION:

889B Black Opaque Parchment
 w/ White Lining

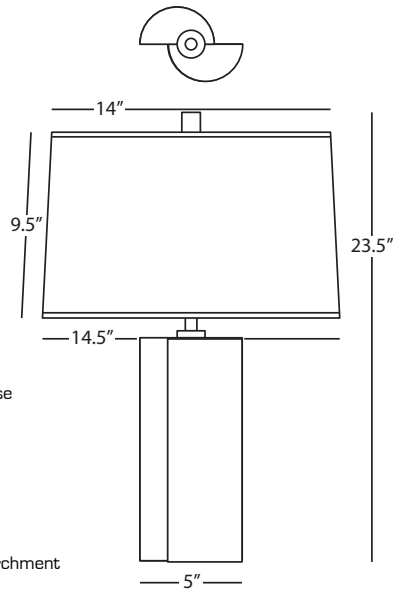

JONATHAN ADLER CANAAN

851B

Tapered Table Lamp

1 - 150W Max.
 Bulb Type: A
 Switch: Hi-Lo Dimming Line Switch
 Carrara and Black Marble Base
 Antique Brass Accents
 Black Opaque Parchment Shade w/
 White Lining
 Black Fabric Wrapped Cord

SHADE OPTION:

851 Oyster Linen

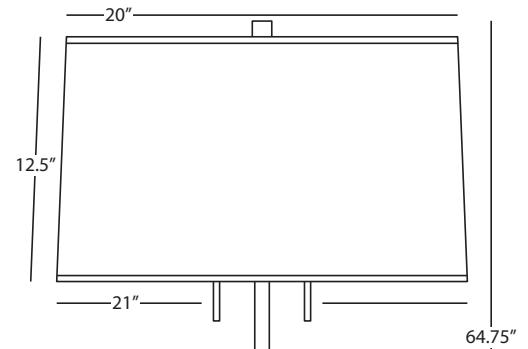
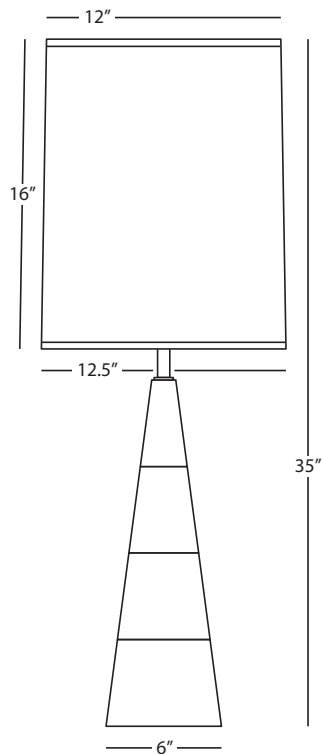

JONATHAN ADLER CANAAN

680

Floor Lamp

2 - 150W Max.
 Bulb Type: A
 Switch: Hi-Lo Pull Chains
 Antique Brass Finish
 Carrara Marble Base
 Oyster Linen Shade
 Perforated Metal Top Diffuser

SHADE OPTION:

680G Smoke Gray Fabric

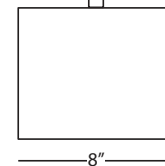

Jonathan Adler Capri



WH734



WH737



WH738



WH730



WH736

Jonathan Adler Capri

JONATHAN ADLER CAPRI

WH736

Accent Lamp

1 - 150W Max.
 Bulb Type: A
 Switch: 3-Way
 White Cased Glass w/
 Polished Nickel Accents
 Translucent Ceramik Blanco
 Parchment Shade

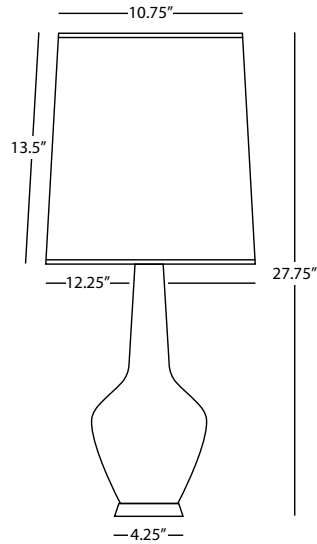

JONATHAN ADLER CAPRI

WH734

Pendant

1 - 100W Max.
 Bulb Type: A
 Direct Wire Only
 White Cased Glass w/
 Polished Nickel Accents
 Susp. Hardware: 11 Ft. White Cord

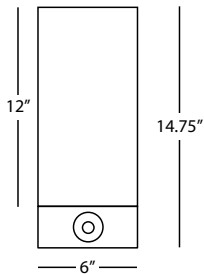
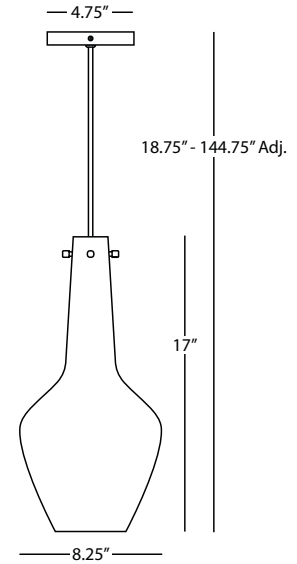

JONATHAN ADLER CAPRI

WH737

Accent Torchiere

1 - 150W Max.
 Bulb Type: A
 Switch: 3-Way
 Walnut Finished Wood Base w/
 Polished Nickel Accents
 White Cased Glass Shade

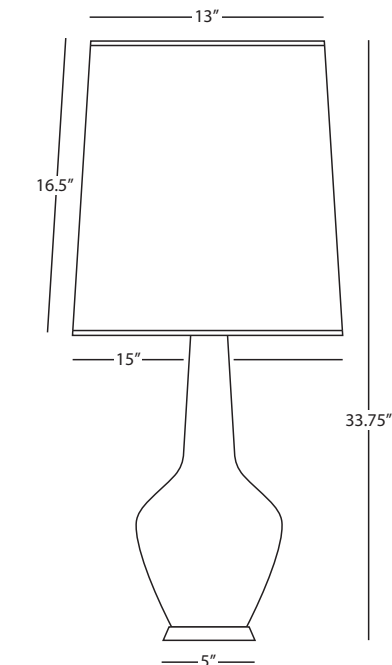

JONATHAN ADLER CAPRI

WH738

Torchiere

1 - 150W Max.
 Bulb Type: A
 Switch: 3-Way
 Walnut Finished Wood Base w/
 Polished Nickel Accents
 White Cased Glass Shade

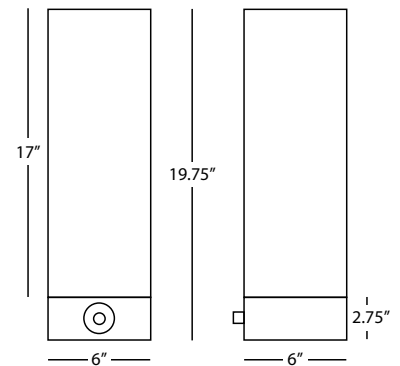

JONATHAN ADLER CAPRI

WH730

Tall Table Lamp

1 - 150W Max.
 Bulb Type: A
 Switch: Full Range Dimmer
 White Cased Glass w/
 Polished Nickel Accents
 Translucent Ceramik Blanco
 Parchment Shade



732



730L



730R

Jonathan Adler Ceramic

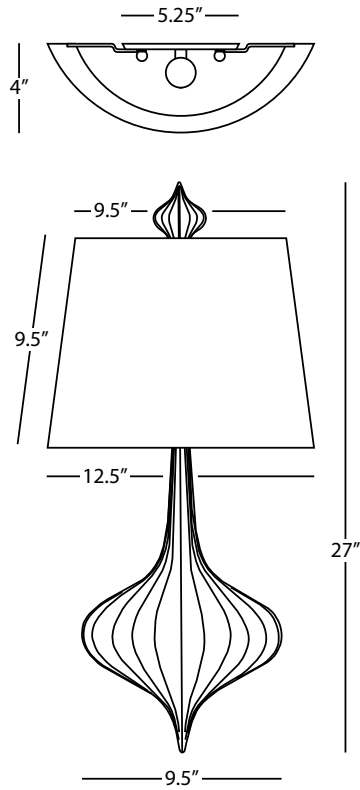

JONATHAN ADLER CERAMIC

732

Lantern Wall Sconce

1 - 60W Max.
 Bulb Type: A
 Direct Wire Only
 Ceramic w/White Glaze Finish
 White Linen Fabric Shade w/
 Rolled Edge Hem
 ADA Compliant

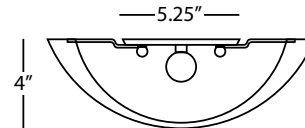
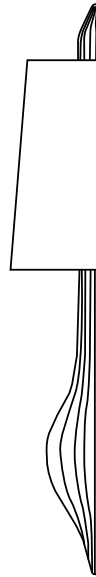

JONATHAN ADLER CERAMIC

730L

Giraffe Wall Sconce (Left Facing)

1 - 60W Max.
 Bulb Type: A
 Direct Wire Only
 Ceramic w/White Glaze Finish
 White Linen Fabric Shade w/
 Rolled Edge Hem
 ADA Compliant

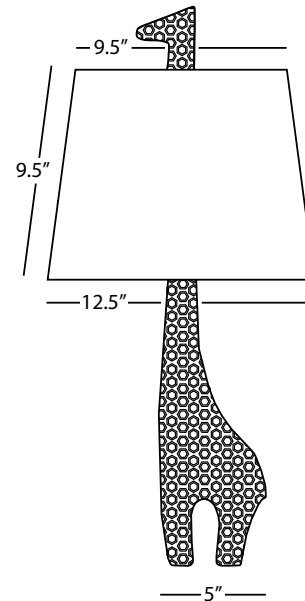

OPTION:

730R Giraffe Wall Sconce (Right Facing)

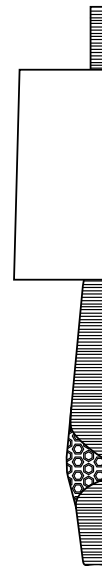



677



676



684B

Jonathan Adler Claridge

JONATHAN ADLER CLARIDGE

684B

Mini Tear Drop Accent Lamp

1 - 40W Max.
Bulb Type: B, Candelabra
Switch: Hi-Lo Line Switch
Lead Crystal w/ Polished Nickel Accents
Black Silk Dupioni Shade w/ Rolled Edge Hem

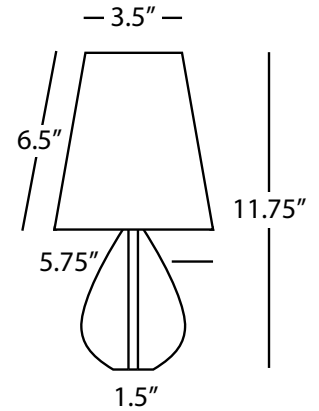

SHADE OPTION:

684 Oyster Gray Silk Dupioni w/ Rolled Edge Hem

JONATHAN ADLER CLARIDGE

677

Component Table Lamp

1 - 100W Max.
Bulb Type: A
Switch: Full Range Dimmer
Lead Crystal w/ Polished Nickel Accents
Oyster Gray Silk Dupioni Shade w/ Rolled Edge Hem

SHADE OPTION:

677B Black Silk Dupioni w/ Rolled Edge Hem

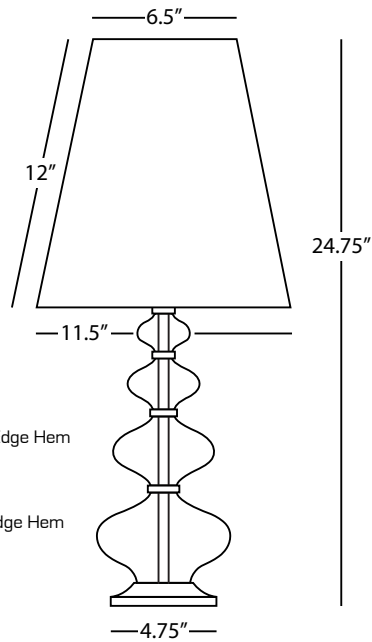

JONATHAN ADLER CLARIDGE

676

Tear Drop Table Lamp

1 - 100W Max.
Bulb Type: A
Switch: Full Range Dimmer
Lead Crystal w/ Polished Nickel Accents
Oyster Gray Silk Dupioni Shade w/
Rolled Edge Hem

SHADE OPTION:

676B Black Silk Dupioni w/ Rolled Edge Hem

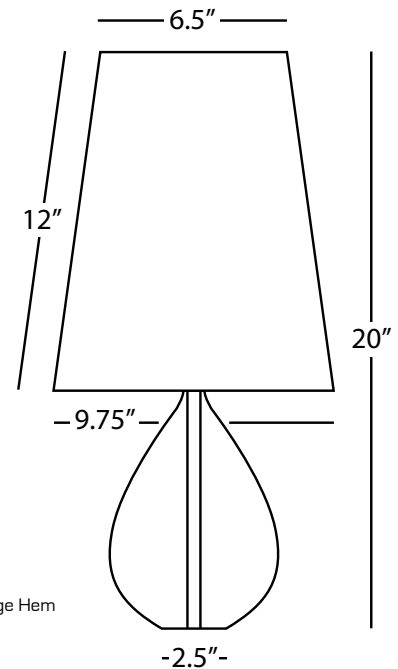

Jonathan Adler Geneva



S925

Jonathan Adler Geneva

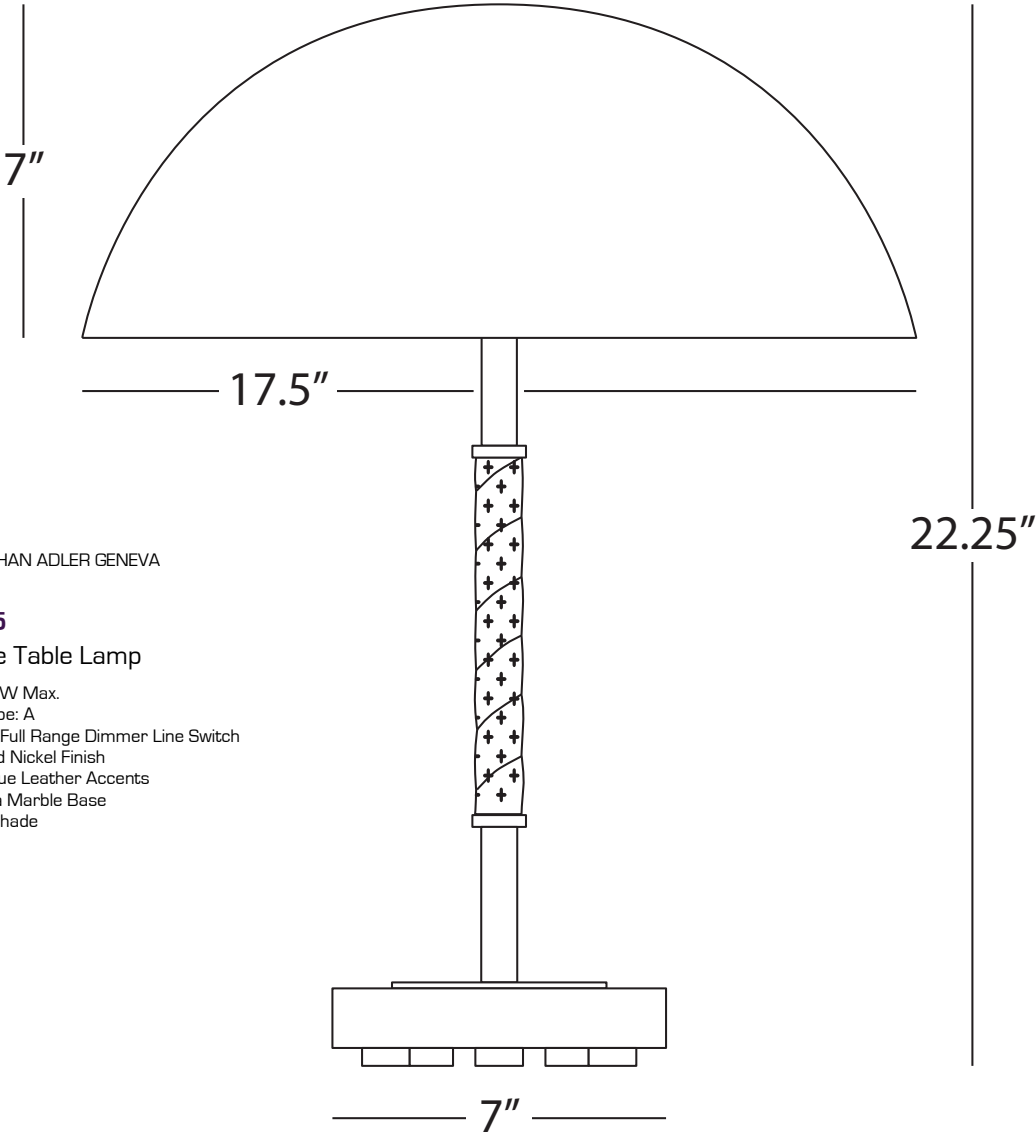

JONATHAN ADLER GENEVA

S925

Dome Table Lamp

- 2 - 100W Max.
- Bulb Type: A
- Switch: Full Range Dimmer Line Switch
- Polished Nickel Finish
- Navy Blue Leather Accents
- Carrara Marble Base
- Metal Shade

Jonathan Adler Harlequin



787



786



S786



S787

Jonathan Adler Harlequin

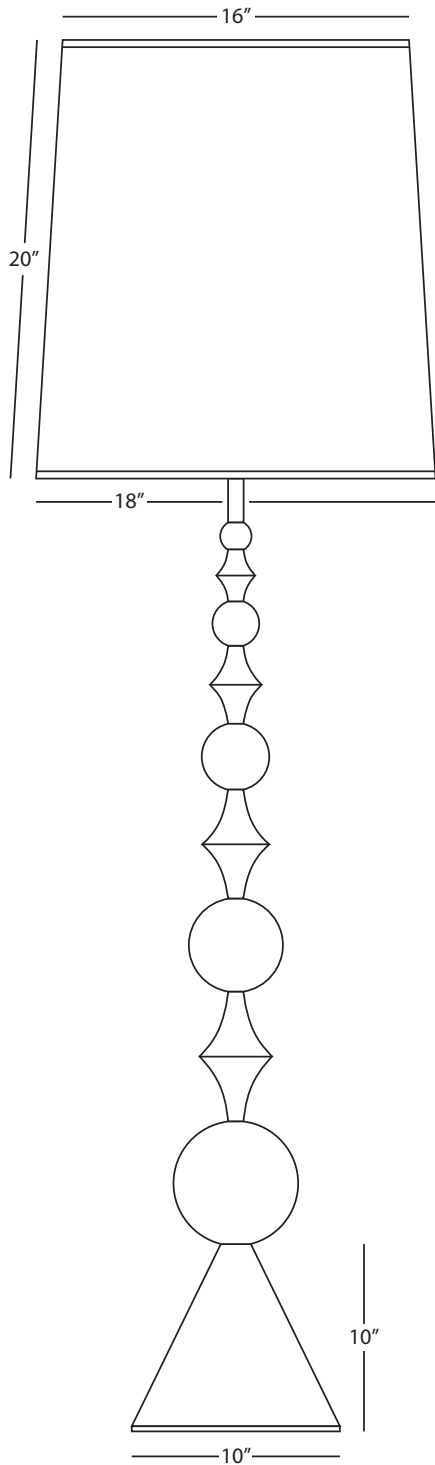

JONATHAN ADLER HARLEQUIN

787

Floor Lamp

1 - 150W Max.
Bulb Type: A
Switch: Hi-Lo Dimming
Antique Brass Finish
Oyster Linen Shade

FINISH OPTION:
S787 Polished Nickel

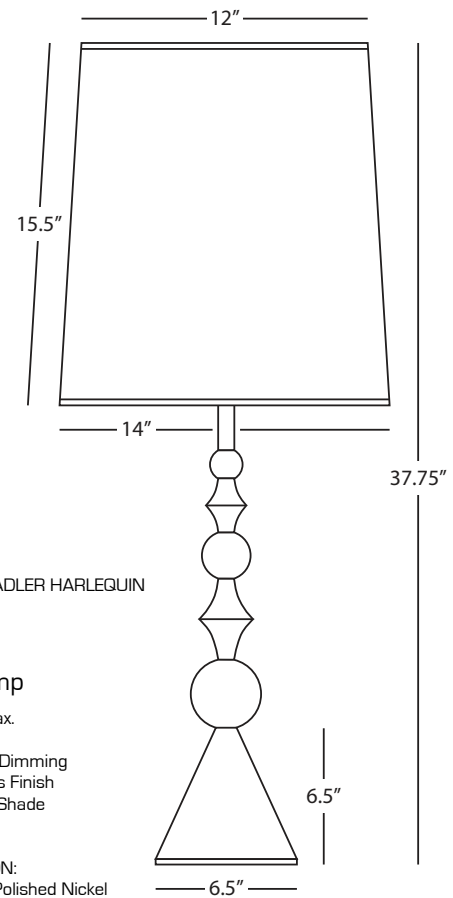

JONATHAN ADLER HARLEQUIN

786

Table Lamp

1 - 150W Max.
Bulb Type: A
Switch: Hi-Lo Dimming
Antique Brass Finish
Oyster Linen Shade

FINISH OPTION:
S786 Polished Nickel

Jonathan Adler Havana



W695



W698



W697



W708

Jonathan Adler Havana

JONATHAN ADLER HAVANA

W708 Double Sconce

2 - 60W Max.
Bulb Type: A
Switch: Hi-Lo Line Switch
24" Cord Cover/Direct Wire
Polished Nickel Finish
Powder Coat White Metal Shades w/
Perforated Design

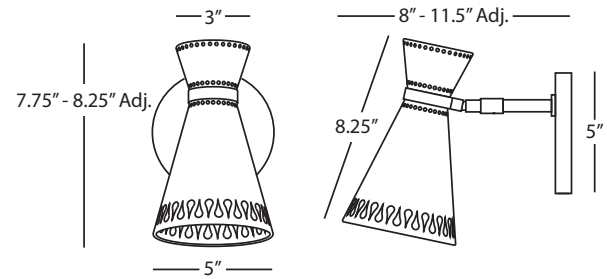
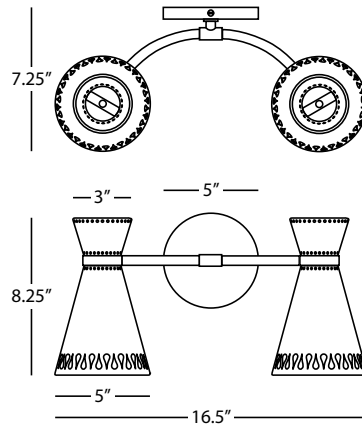

JONATHAN ADLER HAVANA

W697 Wall Sconce

1 - 60W Max.
Bulb Type: A
Switch: Hi-Lo Dimming
24" Cord Cover/Direct Wire
Polished Nickel Finish
Adjustable, Powder Coat White Metal Shade
w/ Perforated Design

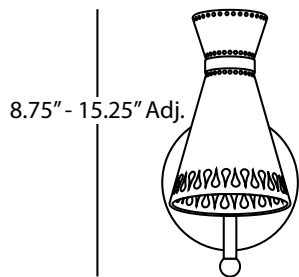

5.75" - 29.75" Adj.

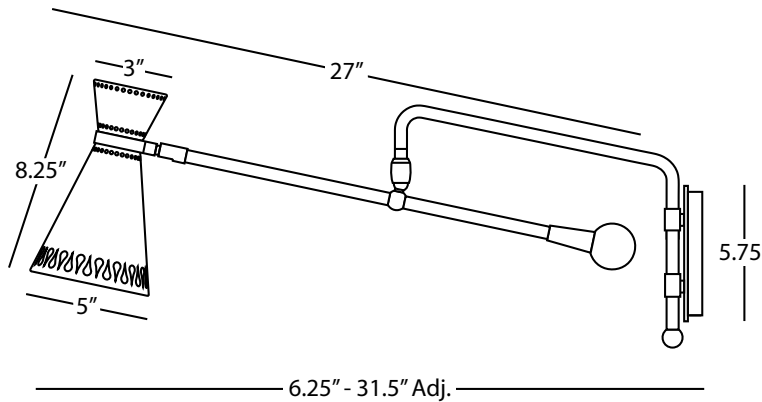

JONATHAN ADLER HAVANA

W695 Wall Boom Lamp

1 - 60W Max.
Bulb Type: A
Switch: Hi-Lo Rotary
24" Cord Cover/Direct Wire
Polished Nickel Finish
Adjustable, Powder Coat White Metal Shade w/
Perforated Design

JONATHAN ADLER HAVANA

W698 Double Shaded Half Round Sconce

2 - 60W Max.
Bulb Type: B, Candelabra
Direct Wire Only
Polished Nickel Finish
Powder Coat White Metal Shades w/ Perforated Design
ADA Compliant
Can Be Mounted Horizontally or Vertically

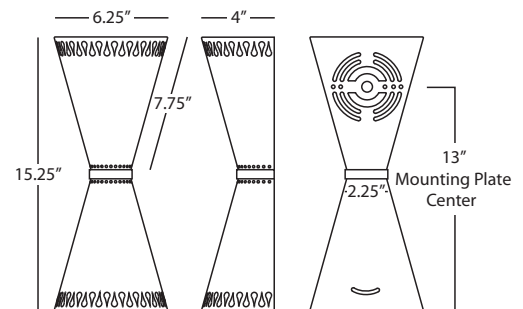



287



448



445

Jonathan Adler Hollywood

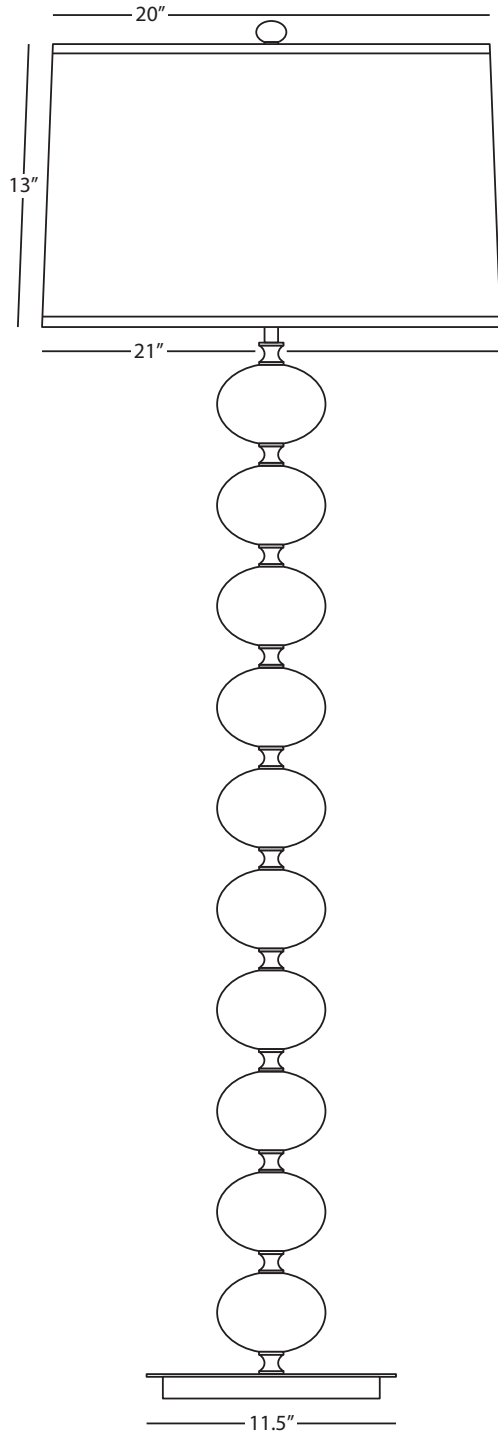

JONATHAN ADLER HOLLYWOOD

445

Havenhurst Table Lamp

1 - 150W Max.
Bulb Type: A
Switch: Full Range Dimmer
Polished Brass Finish
Oyster Linen Shade

FINISH OPTION:

446 Polished Nickel

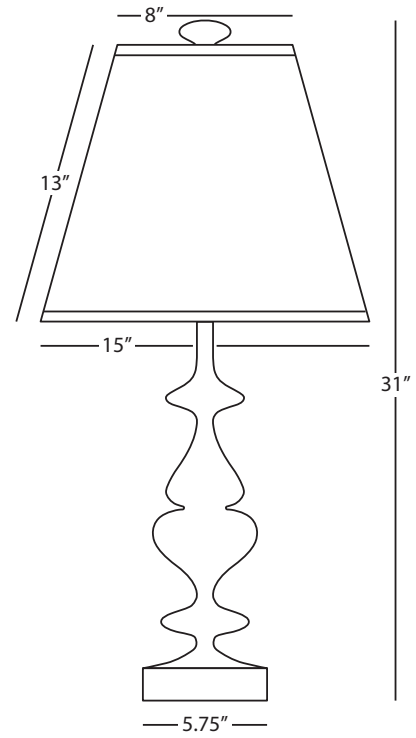

JONATHAN ADLER HOLLYWOOD

448

Floor Lamp

1 - 150W Max.
Bulb Type: A
Switch: Full Range Dimmer
Polished Nickel Finish
Oyster Linen Shade

FINISH OPTION:

447 Polished Brass

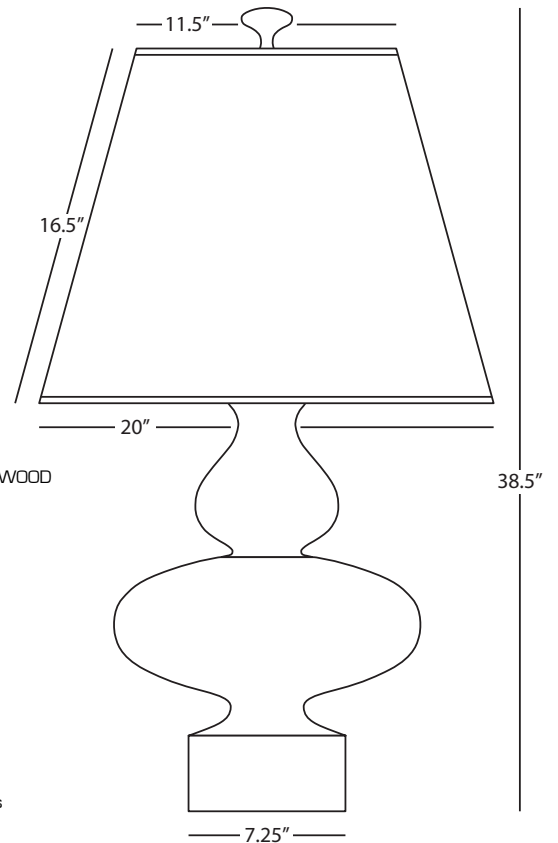

JONATHAN ADLER HOLLYWOOD

286

Bel Air Table Lamp

1 - 150W Max.
Bulb Type: A
Switch: Full Range Dimmer
Polished Nickel Finish
Oyster Linen Shade

FINISH OPTION:

287 Polished Brass

Jonathan Adler Jupiter



3542

Jonathan Adler Jupiter

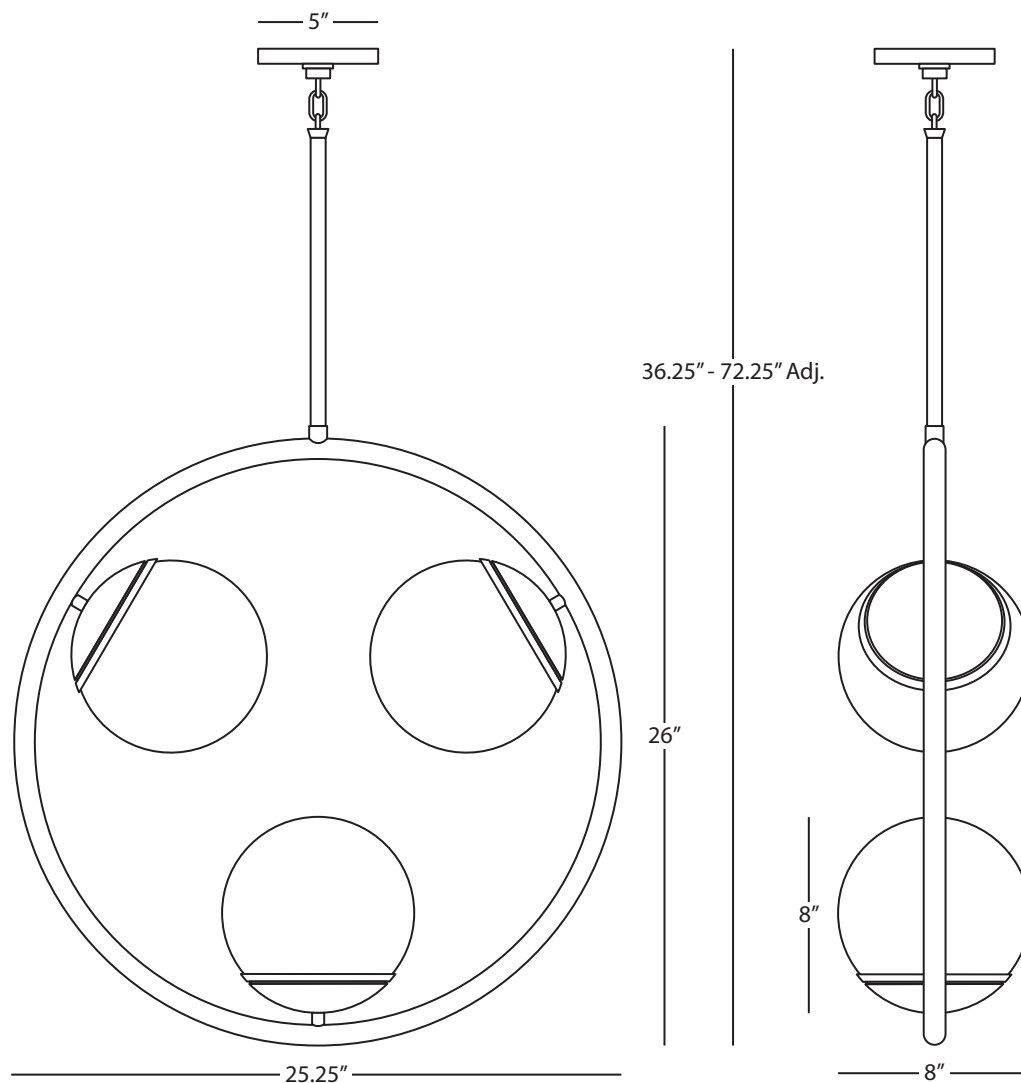

JONATHAN ADLER JUPITER

3542

Chandelier

3 - 60W Max.

Bulb Type: A

Direct Wire

Modern Brass Finish

Cased White Glass Globe Shades

Susp. Hardware: 1 pc. 5/8" x 6" & 3 pcs.

5/8" x 12" Extensions

FINISH OPTION:

S3542 Polished Nickel



S633



632

Jonathan Adler Maxime

JONATHAN ADLER MAXIME

S633 Wall Sconce

2 - 60W Max.
Bulb Type: B, Medium Base
Direct Wire Only
Polished Nickel Finish
White Glass Shades
UL Rated Damp Locations

FINISH OPTIONS:
633 Modern Brass

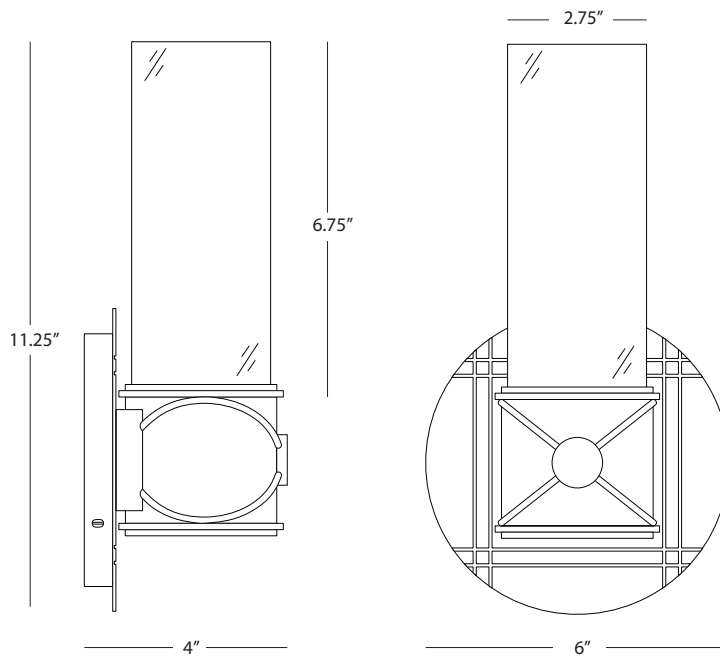
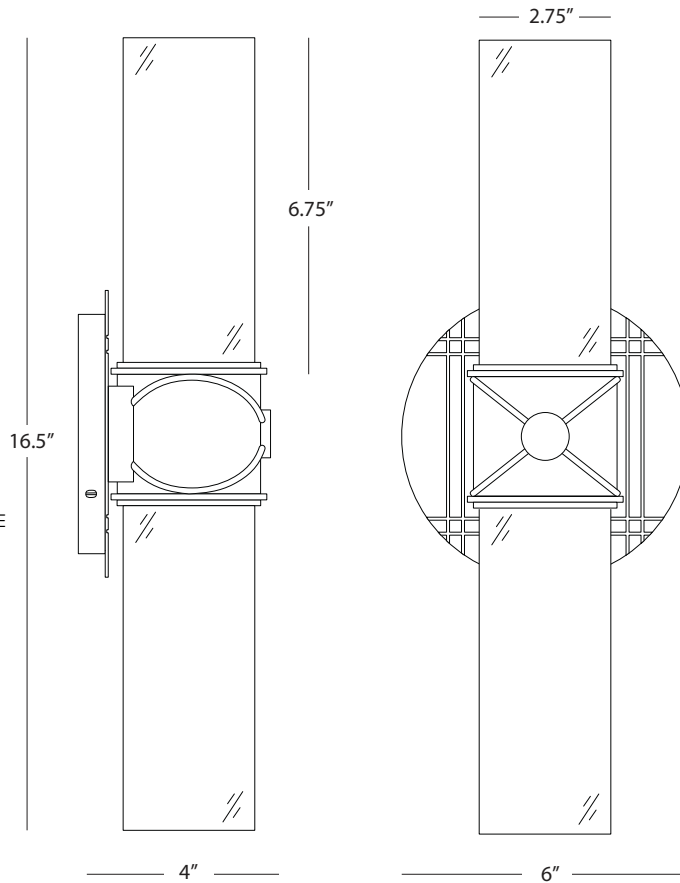

JONATHAN ADLER MAXIME

632 Wall Sconce

1 - 60W Max.
Bulb Type: B, Medium Base
Direct Wire Only
Modern Brass Finish
White Glass Shade
UL Rated Damp Locations

FINISH OPTIONS:
S632 Polished Nickel



S651X



Z647

Jonathan Adler Meurice

JONATHAN ADLER MEURICE

Z647

Adjustable Task Floor Lamp

1 - 60W Max.
Bulb Type: A
Switch: Full Range Foot Dimmer
Deep Patina Bronze Finish
Metal Shade

FINISH OPTIONS:

647 Modern Brass
S647 Polished Nickel

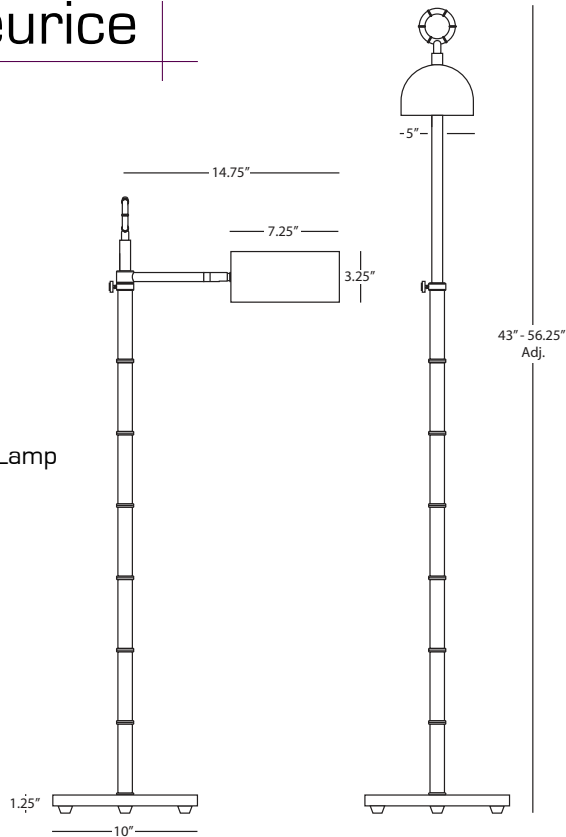

JONATHAN ADLER MEURICE

651

Club Floor Lamp

1 - 150W Max.
Bulb Type: A
Switch: Full Range Dimmer
Modern Brass Finish
Off-White Linen Shade with
Rolled Edge Hem

FINISH/SHADE OPTIONS:

651B Modern Brass
Black Parchment Shade
w/ Matte Gold Lining

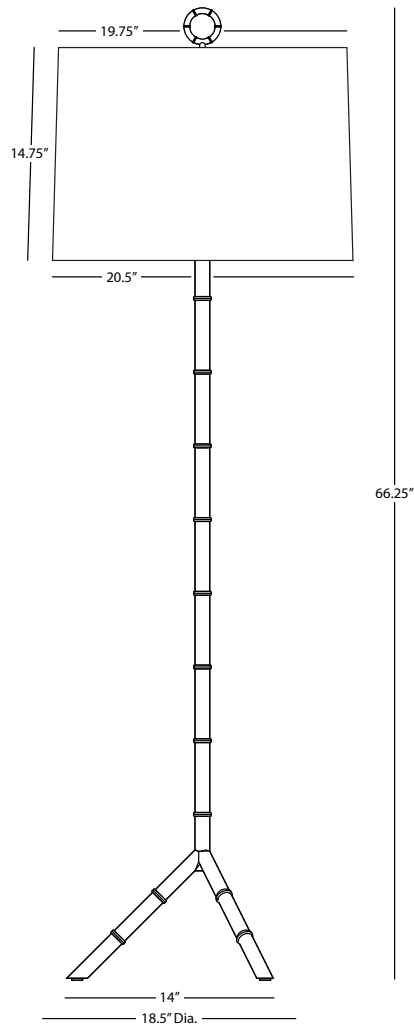



764



Z657



S654

Jonathan Adler Meurice

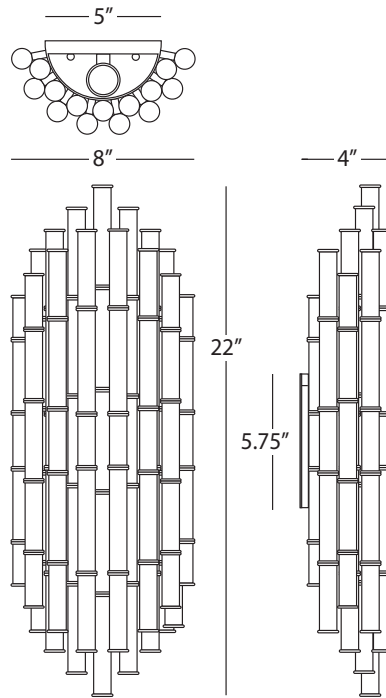

JONATHAN ADLER MEURICE

764 Half Round Wall Sconce

2 - 40W Max.
Bulb Type: B, Medium Base
Direct Wire Only
Modern Brass Finish
ADA Compliant

FINISH OPTIONS:

S764 Polished Nickel
Z764 Deep Patina Bronze

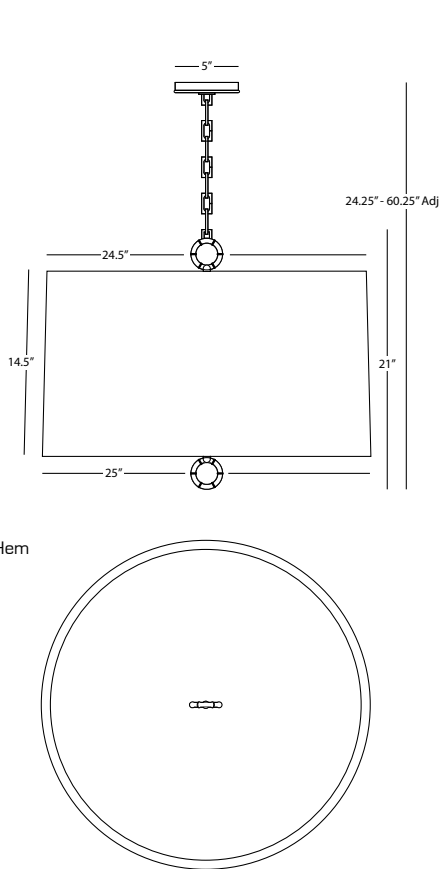

JONATHAN ADLER MEURICE

Z657 Large Pendant

3 - 100W Max.
Bulb Type: A
Direct Wire Only
Deep Patina Bronze Finish
Off-White Linen Shade w/ Rolled Edge Hem
24" Acrylic Diffuser
Susp. Hardware: 3 Ft. Chain

FINISH OPTIONS:

S657 Polished Nickel

JONATHAN ADLER MEURICE

S654 30-Light Chandelier

30 - 25W Max.
Bulb Type: G16.5 Candelabra
Direct Wire Only
Polished Nickel Finish
Susp. Hardware: 3 pcs. 5/8" x 12"
& 1 pc. 5/8" x 6" Extensions

FINISH OPTIONS:

654 Modern Brass

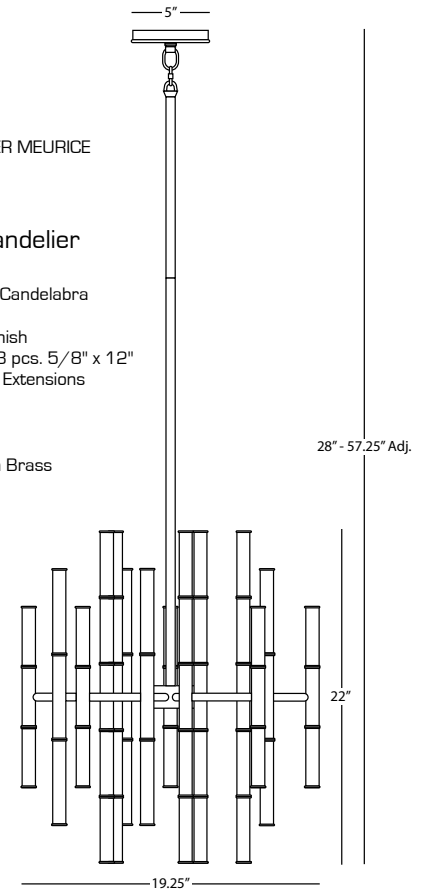



686

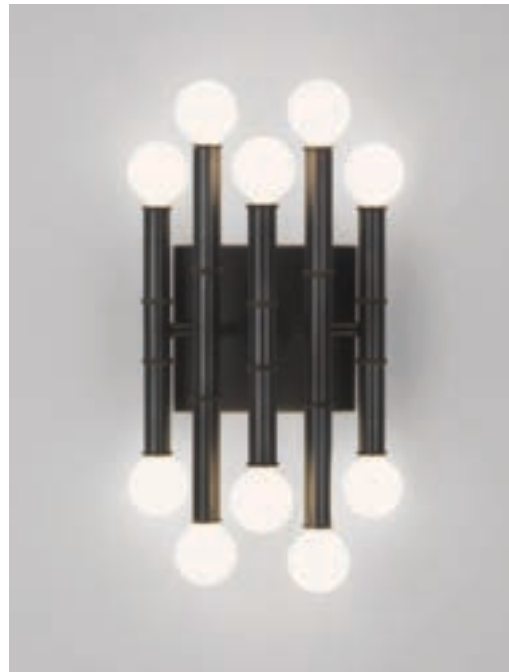

Z686



S687

Jonathan Adler Meurice

JONATHAN ADLER MEURICE

686

5-Arm Sconce

10 - 25W Max.
 Bulb Type: G16.5 Candelabra
 24" Cord Cover/ Direct Wire
 Modern Brass Finish

FINISH OPTIONS:

- S686** Polished Nickel
- Z686** Deep Patina Bronze

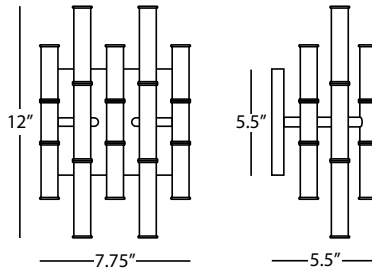
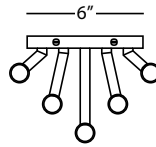

JONATHAN ADLER MEURICE

S687

Rectangular Chandelier

42 - 25W Max.
 Bulb Type: G16.5 Candelabra
 Direct Wire Only
 Polished Nickel Finish
 Susp. Hardware: 6 pcs. 5/8" x 12" &
 2 pcs. 5/8" x 6" Extensions

FINISH OPTIONS:

- 687** Modern Brass
- Z687** Deep Patina Bronze

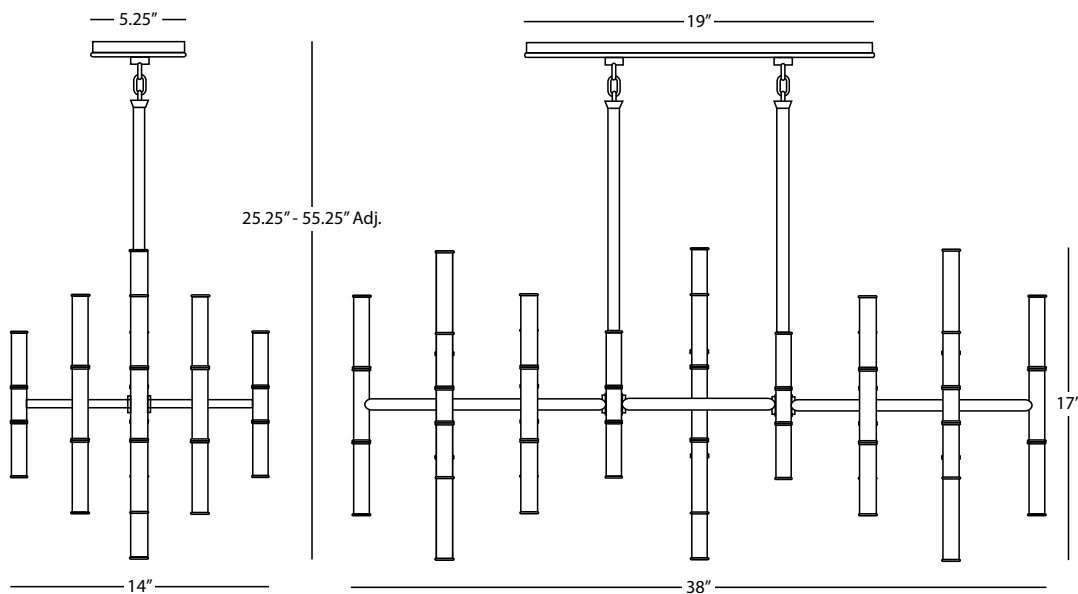
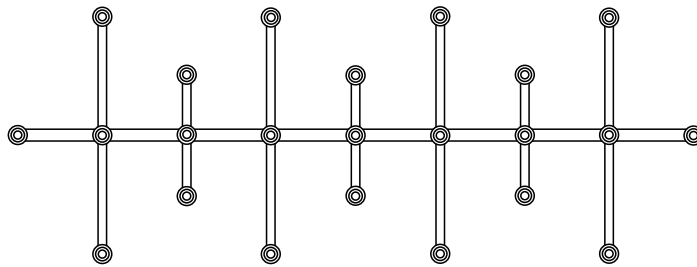



S689



763



Z761



S760

Jonathan Adler Meurice

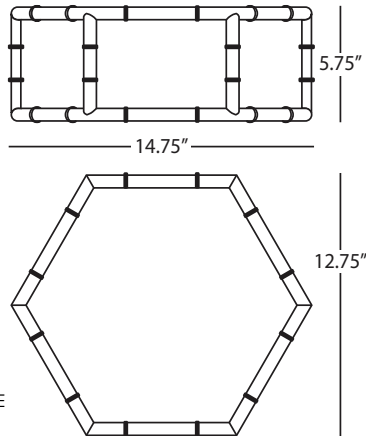

JONATHAN ADLER MEURICE

763

Hexagonal Flush Mount

3 - 40W Max.
Bulb Type: A
Direct Wire
Modern Brass Finish
Frosted White Glass Shade

FINISH OPTIONS:

S763 Polished Nickel
Z763 Deep Patina Bronze

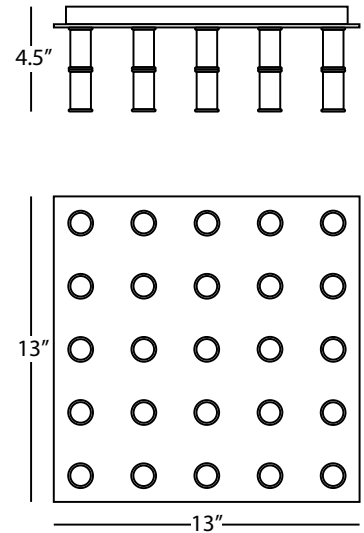

JONATHAN ADLER MEURICE

689

25-Light Flush Mount

25 - 15W Max.
Bulb Type: G16.5, Candelabra
Direct Wire Only
Modern Brass Finish

FINISH OPTIONS:

S689 Polished Nickel
Z689 Deep Patina Bronze

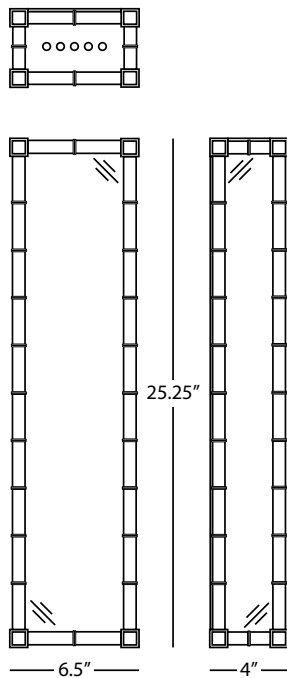

JONATHAN ADLER MEURICE

Z761

Medium Wall Sconce

3 - 60W Max.
Bulb Type: B11 Torpedo
Direct Wire Only
Deep Patina Bronze Finish
Frosted White Glass Shade
ADA Compliant

FINISH OPTION:

S761 Polished Nickel

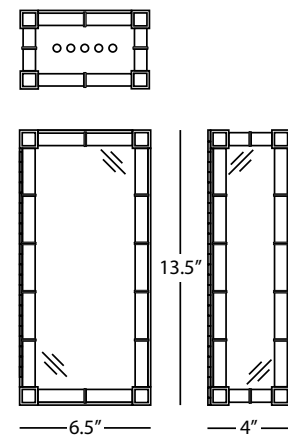

JONATHAN ADLER MEURICE

S760

Small Wall Sconce

2 - 60W Max.
Bulb Type: B11 Torpedo
Direct Wire Only
Polished Nickel Finish
Frosted White Glass Shade
ADA Compliant

FINISH OPTION:

Z760 Deep Patina Bronze



645G



S645B

Jonathan Adler Meurice

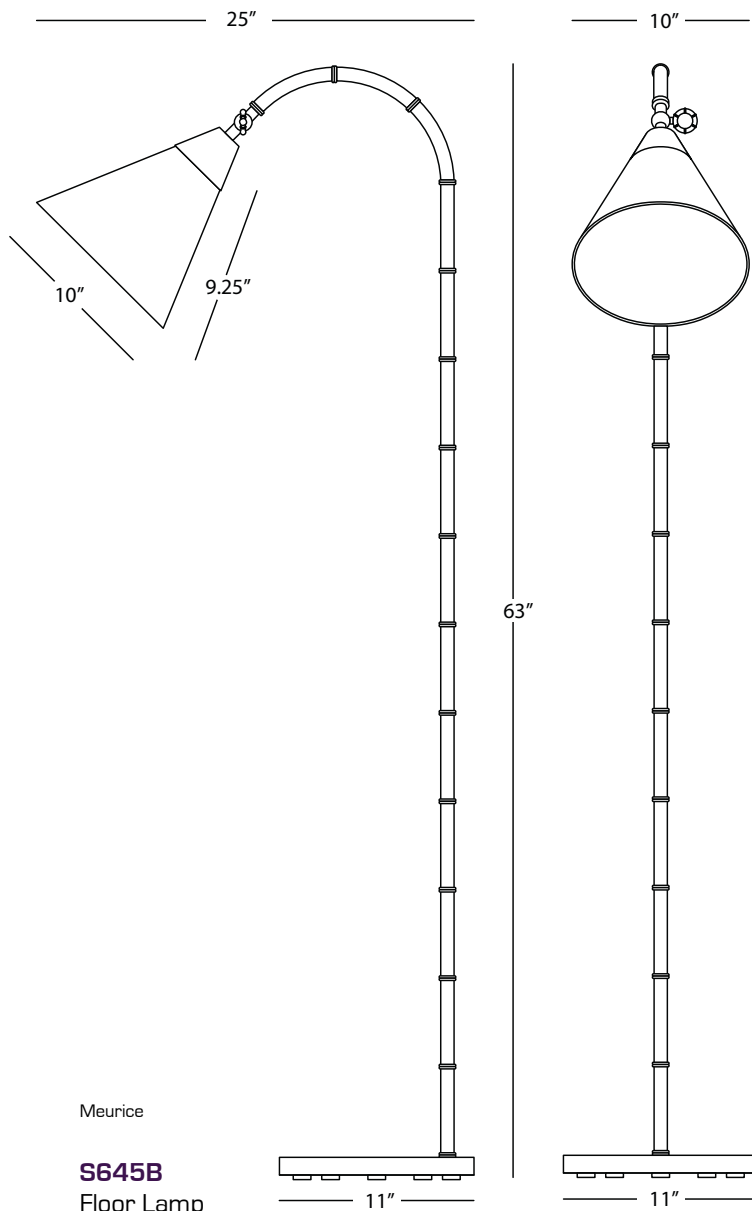

Meurice

S645B

Floor Lamp

1 - 5W Max.
Bulb Type: A (LED)
Switch: Full Range Dimmer Line Switch
Polished Nickel Finish
Black Opaque Parchment Shade
with Matte Silver Lining

FINISH OPTIONS:

- 645B** Modern Brass/Black Opaque Parchment w/
Matte Gold Lining
- 645G** Modern Brass/Cased White Glass
- S645G** Polished Nickel/Cased White Glass



659



S724



723

Jonathan Adler Meurice

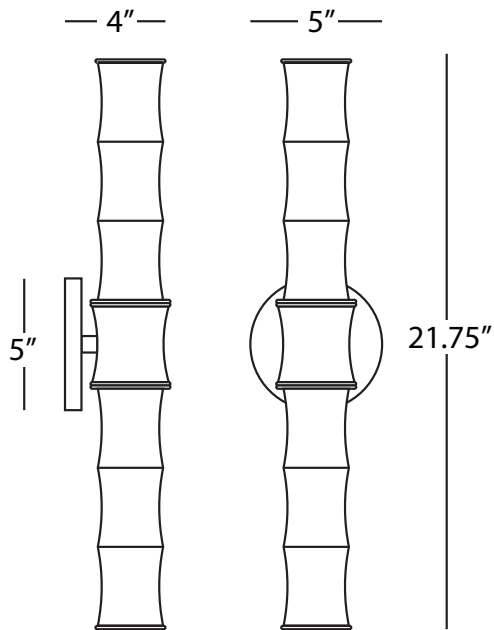

Meurice

659 Wall Sconce

2 - 4W Max.
Bulb Type: 120V G9 Bi-Pin LED
Switch: On/Off Line Switch
24" Cord Cover/Direct Wire
Modern Brass Finish
Cased White Glass Shades

FINISH OPTIONS:
S659 Polished Nickel

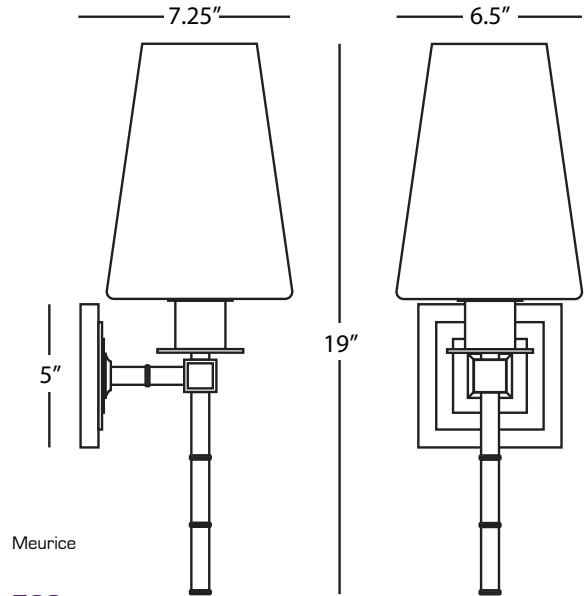

Meurice

723 Wall Sconce

1 - 60W Max.
Bulb Type: A
Switch: On/Off Line Switch
24" Cord Cover/Direct Wire
Modern Brass Finish
Cased White Glass Shade

FINISH OPTIONS:
S723 Polished Nickel

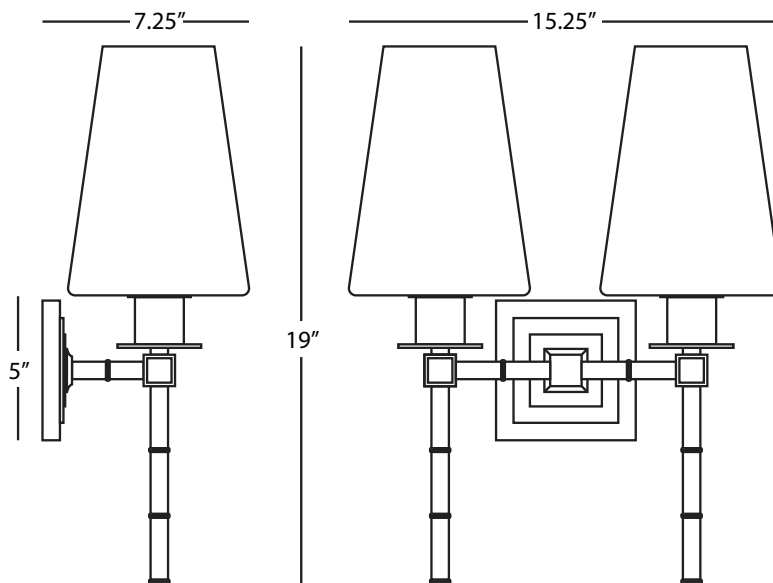

Meurice

S724 Wall Sconce

2 - 60W Max.
Bulb Type: A
Switch: On/Off Line Switch
24" Cord Cover/Direct Wire
Polished Nickel Finish
Cased White Glass Shades

FINISH OPTIONS:
724 Modern Brass



723W



S724W

Jonathan Adler Meurice

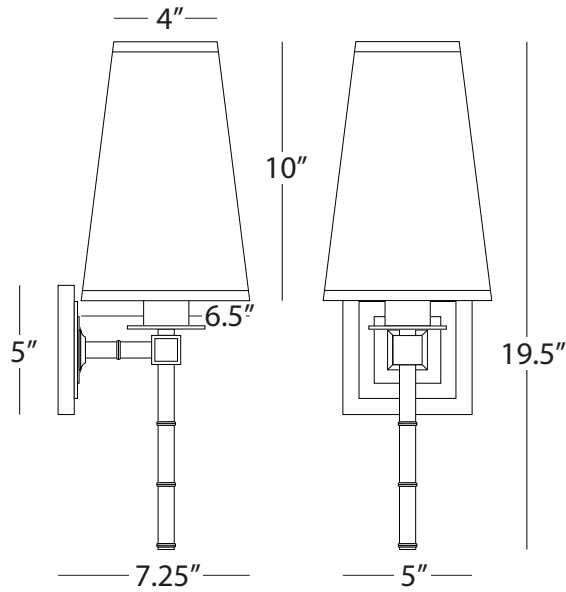

JONATHAN ADLER MEURICE

723W Wall Sconce

1 - 60W Max.
Bulb Type: A
Switch: On-Off Line Switch
24" Cord Cover/Direct Wire
Modern Brass Finish
Pearl Dupioni Fabric Shade

FINISH OPTIONS:
S723W Polished Nickel

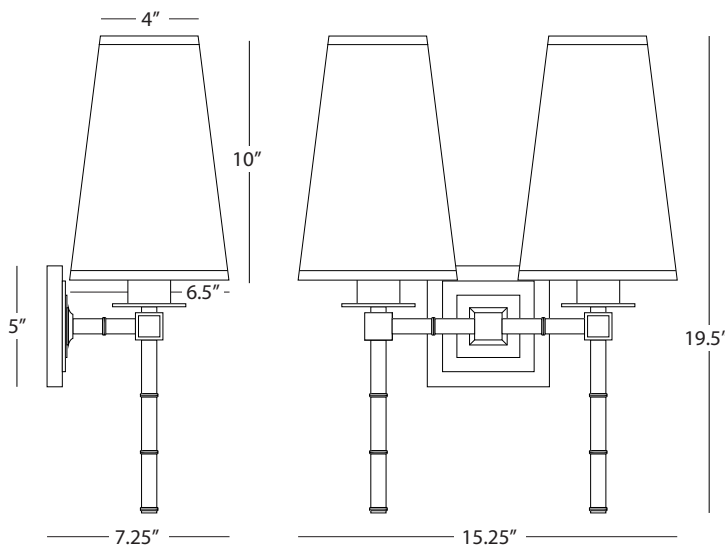

JONATHAN ADLER MEURICE

S724W Wall Sconce

2 - 60W Max.
Bulb Type: A
Switch: On-Off Line Switch
24" Cord Cover/Direct Wire
Polished Nickel Finish
Pearl Dupioni Fabric Shades

FINISH OPTIONS:
724W Modern Brass



636



S637

Jonathan Adler Meurice

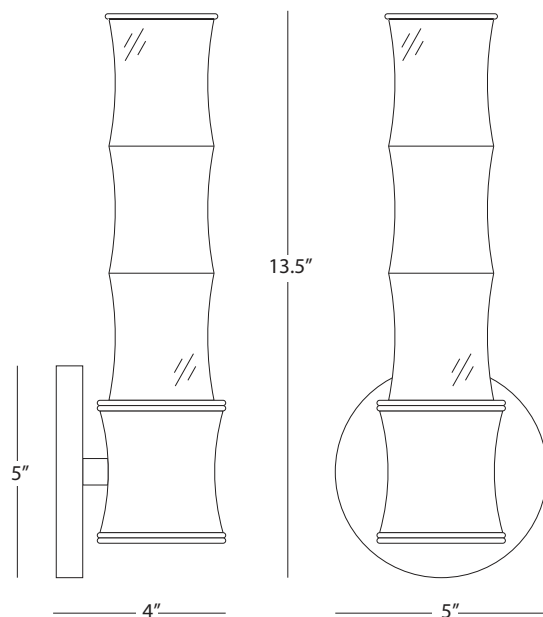

JONATHAN ADLER MEURICE

636 Bamboo Wall Sconce

1 - 4W Max.
Bulb Type: 120V G9 Bi-Pin LED
Switch: On-Off Line Switch
24" Cord Cover / Direct Wire
Modern Brass Finish
Cased White Glass Shade
UL Rated Damp Locations

FINISH OPTIONS:
S637 Polished Nickel

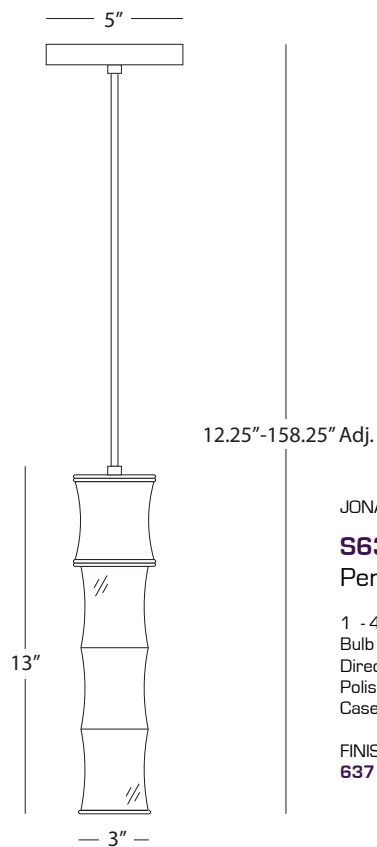

JONATHAN ADLER MEURICE

S637 Pendant

1 - 4W Max.
Bulb Type: 120V G9 Bi-Pin LED
Direct Wire Only
Polished Nickel Finish
Cased White Glass Shade

FINISH OPTIONS:
637 Modern Brass



S634B



634

Jonathan Adler Meurice

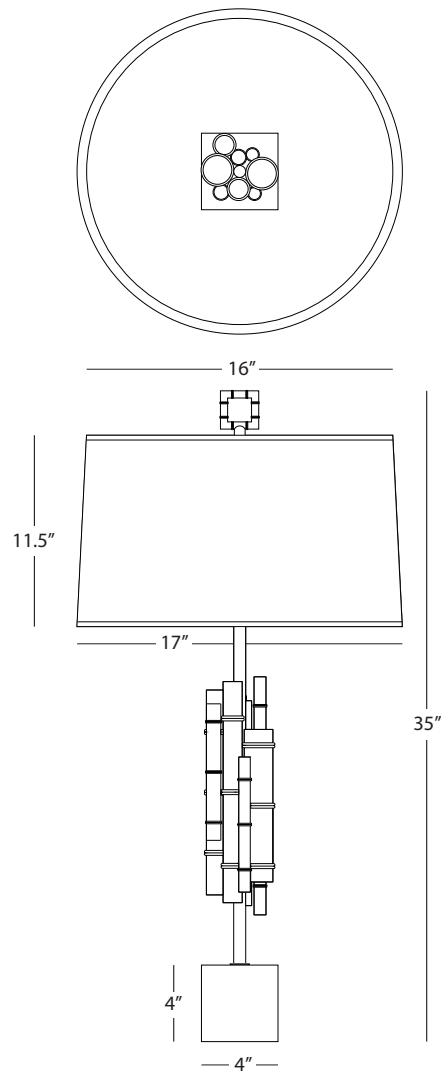

JONATHAN ADLER MEURICE

S634B Bamboo Table Lamp

1 - 150W Max.
Bulb Type: A
Switch: Full Range Dimmer
Polished Nickel Finish
Black Painted Metal Accent
Black Opaque Parchment Shade
with Matte Silver Lining

FINISH OPTIONS:

634 Modern Brass/Pearl Dupioni
S634 Polished Nickel/Pearl Dupioni
634B Modern Brass/Black Opaque
Parchment with Matte Gold Lining

Jonathan Adler Milano



Jonathan Adler Milano

Click photo above to watch Jonathan Adler Milano Video

One of our favorite collections by designer Jonathan Adler, Milano is architecturally dynamic but also graceful, light, and airy. We're introducing an over-sized linear chandelier to the Milano collection this market, measuring 60" in length. This piece makes a grand and distinguishing statement.

Jonathan Adler Milano



S905



803



WB754

Jonathan Adler Milano

JONATHAN ADLER MILANO

S905

Linear Chandelier

22 - 40W Max.
 Bulb Type: G, Candelabra
 Direct Wire
 Polished Nickel Finish w/
 Lucite Accents
 Susp. Hardware: 6 pcs. 5/8" x 12" &
 2 pcs. 5/8" x 6" Extensions

FINISH OPTIONS:

905 Polished Brass
WB905 Warm Brass
Z905 Deep Patina Bronze

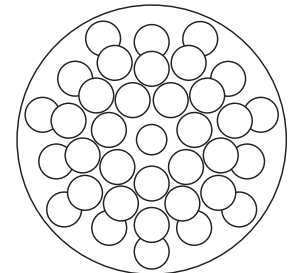
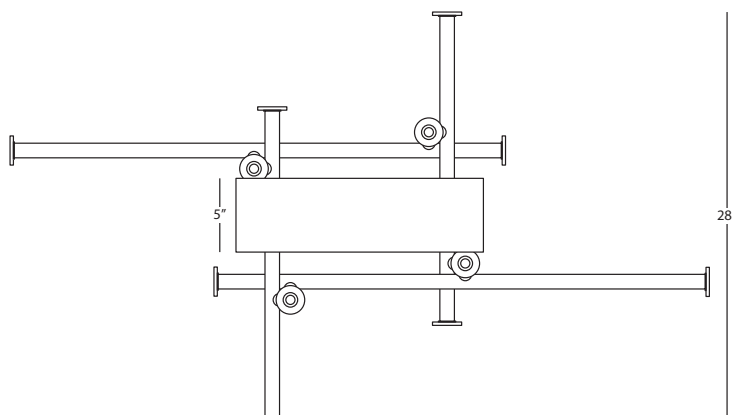
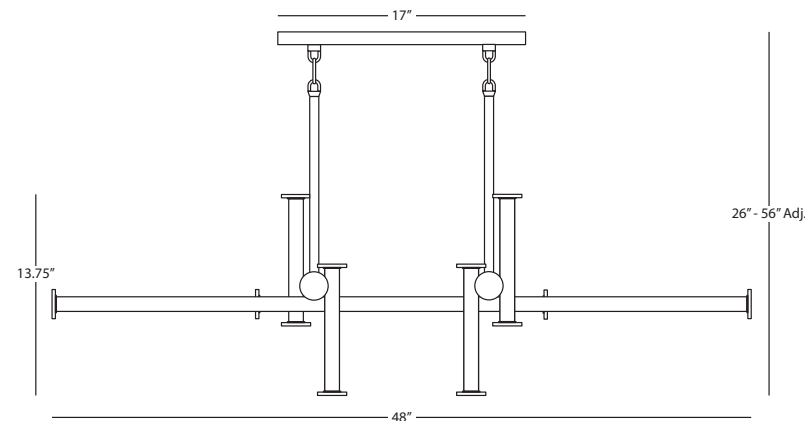
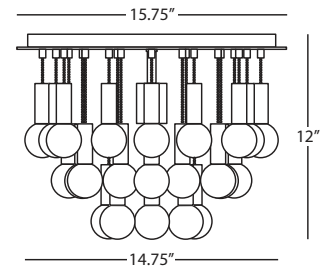
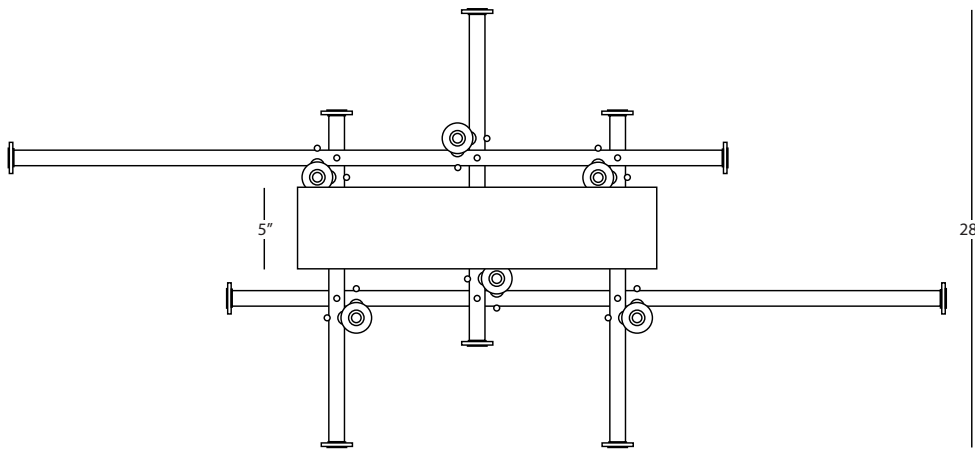
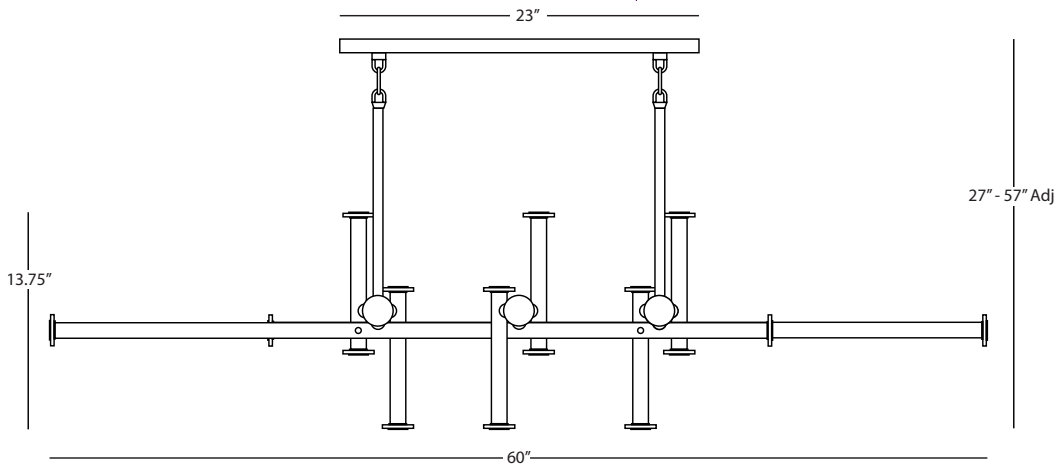

JONATHAN ADLER MILANO

WB754

Flush Mount

1 - 60W Max.
 Bulb Type: A
 Direct Wire
 Warm Brass Finish
 Crystal Accents

Ships with Silver Tip Bulb
 [BUL01 See page 272]

FINISH OPTIONS:

754 Polished Brass
S754 Polished Nickel
Z754 Deep Patina Bronze

JONATHAN ADLER MILANO

803

Linear Chandelier

16 - 40W Max.
 Bulb Type: G, Candelabra
 Direct Wire
 Polished Brass Finish w/
 Lucite Accents
 Susp. Hardware: 6 pcs. 5/8" x 12" &
 2 pcs. 5/8" x 6" Extensions

FINISH OPTIONS:

S803 Polished Nickel
WB803 Warm Brass
Z803 Deep Patina Bronze



WB399



902



Z901

Jonathan Adler Milano

JONATHAN ADLER MILANO

WB399

Component Chandelier

30 - 40W Max.
 Bulb Type: G, Candelabra
 Direct Wire
 Warm Brass Finish
 Susp. Hardware: 6 pcs. 5/8" x 12"
 & 2 pcs. 5/8" x 6" Extensions

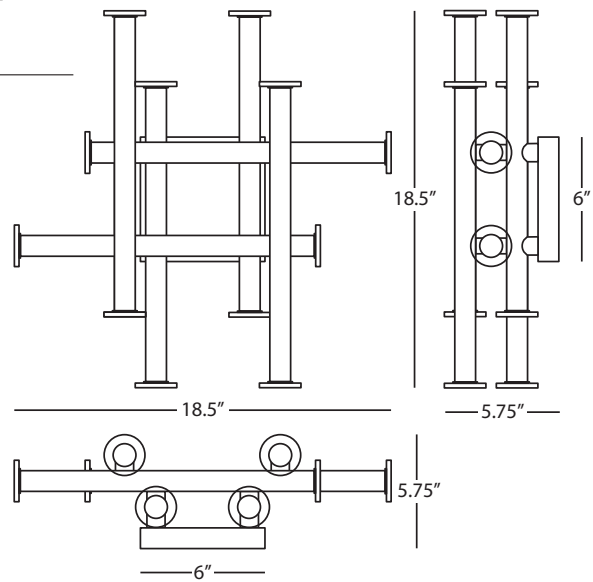
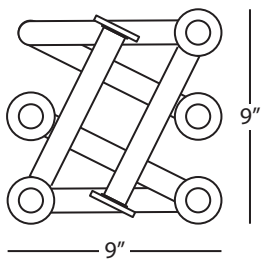
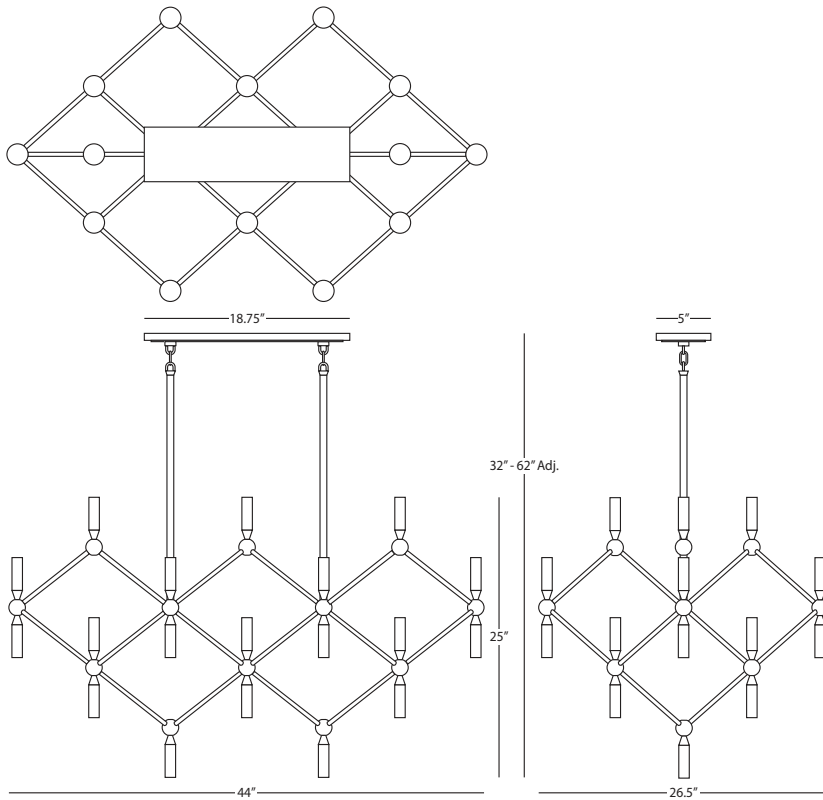

JONATHAN ADLER MILANO

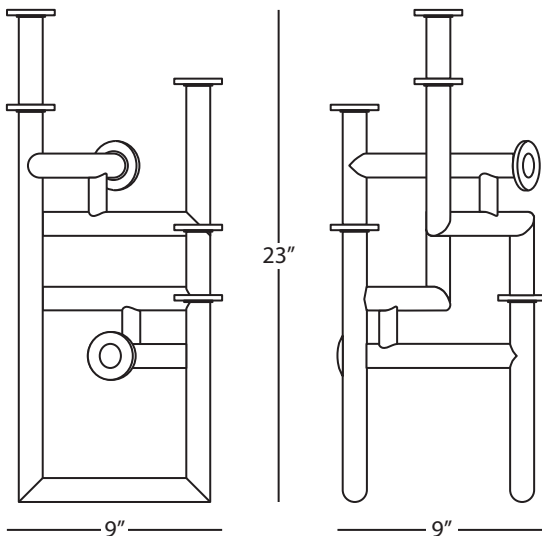

JONATHAN ADLER MILANO

902 Modernist Table Lamp

7 - 40W Max.
 Bulb Type: G, Candelabra
 Switch: Full Range Dimmer Line Switch
 Polished Brass Finish w/
 Lucite Accents

FINISH OPTIONS:
S902 Polished Nickel
WB902 Warm Brass
Z902 Deep Patina Bronze

S901

Linear Wall Sconce

12 - 25W Max.
 Bulb Type: G, Candelabra
 Direct Wire Only
 Polished Nickel Finish w/
 Lucite Accents

FINISH OPTIONS:
901 Polished Brass
WB901 Warm Brass
Z901 Deep Patina Bronze



WB804



S906



903

Jonathan Adler Milano

JONATHAN ADLER MILANO

S906 Kinetic Chandelier

8 - 60W Max.
Bulb Type: G, Medium Base
Direct Wire
Polished Nickel Finish
Susp. Hardware: 1 pc. 5/8" x 6" & 3 pcs.
5/8" x 12" Extensions

Photographed with Silver Tip Bulbs
SOLD SEPARATELY
(BULS1 [x 8] See Page 225)

FINISH OPTIONS:
906 Polished Brass
WB906 Warm Brass
Z906 Deep Patina Bronze

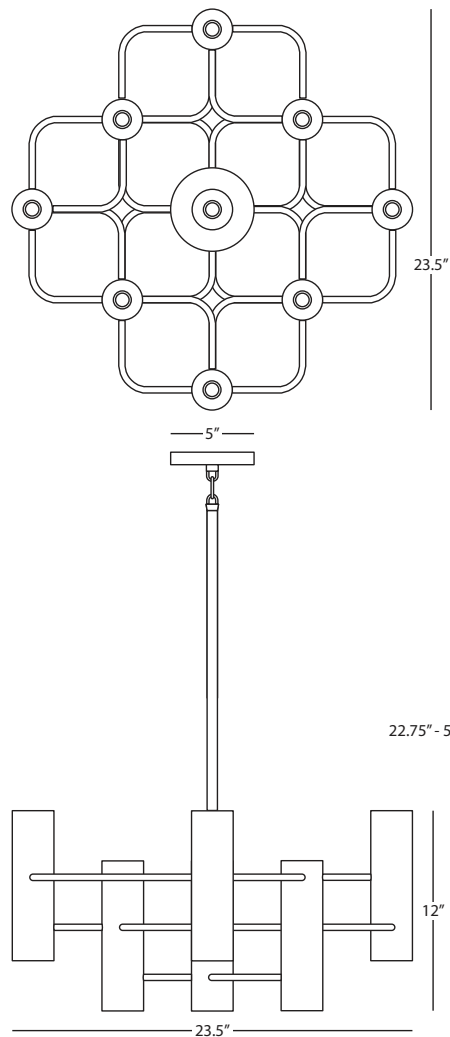
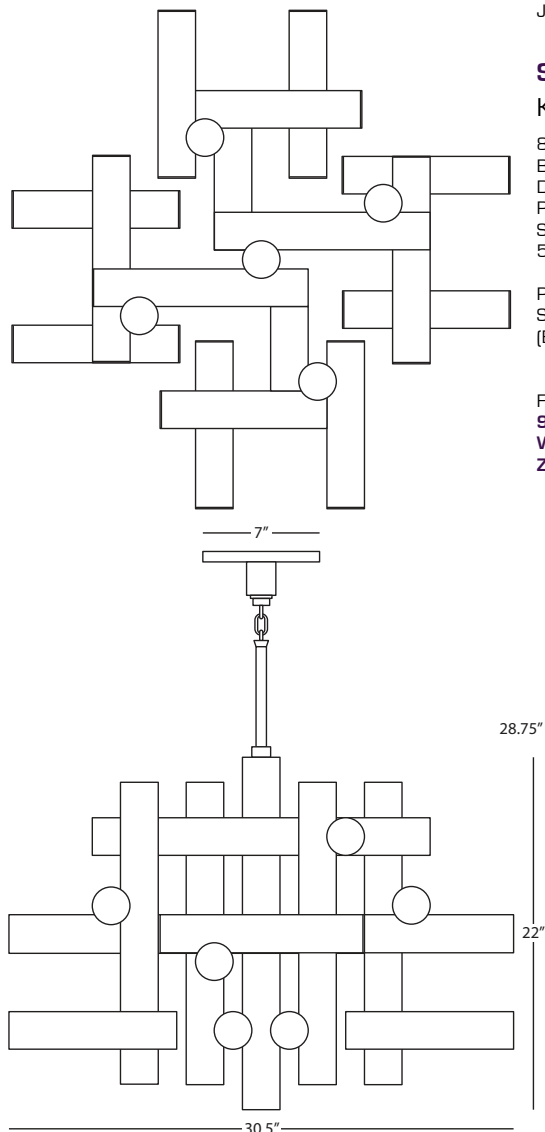

JONATHAN ADLER MILANO

JONATHAN ADLER MILANO

WB804 Square Flush Mount

9 - 60W Max.
Bulb Type: G, Candelabra
Direct Wire
Warm Brass Finish

FINISH OPTIONS:
804 Polished Brass
S804 Polished Nickel
Z804 Deep Patina Bronze

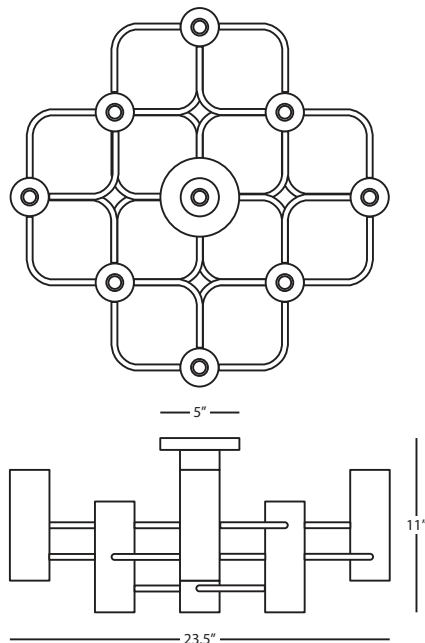

903 Square Pendant

17 - 40W Max.
Bulb Type: G, Medium Base
Direct Wire
Polished Brass Finish
Susp. Hardware: 1 pc. 5/8" x 6" & 3 pcs.
5/8" x 12" Extensions

FINISH OPTIONS:
S903 Polished Nickel
WB903 Warm Brass
Z903 Deep Patina Bronze

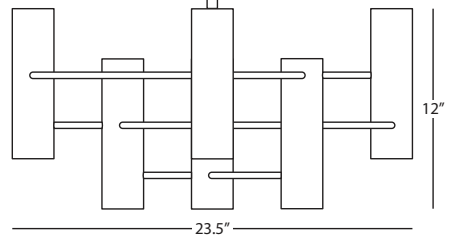

Jonathan Adler Monaco

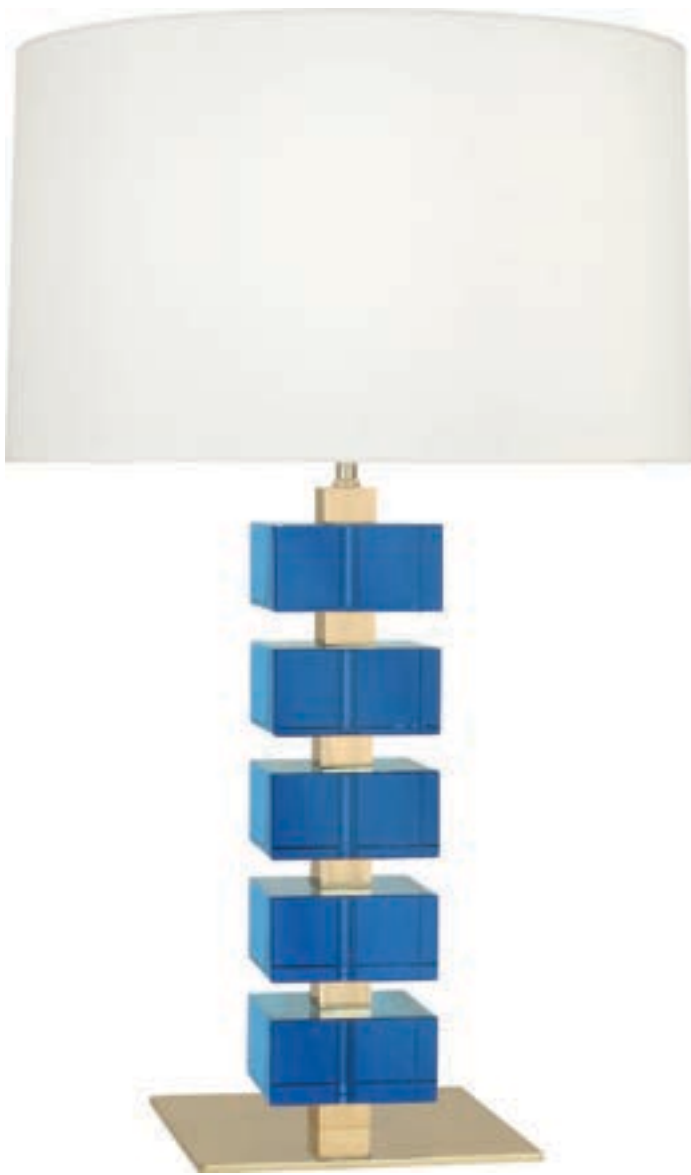

176X



175

Jonathan Adler Monaco

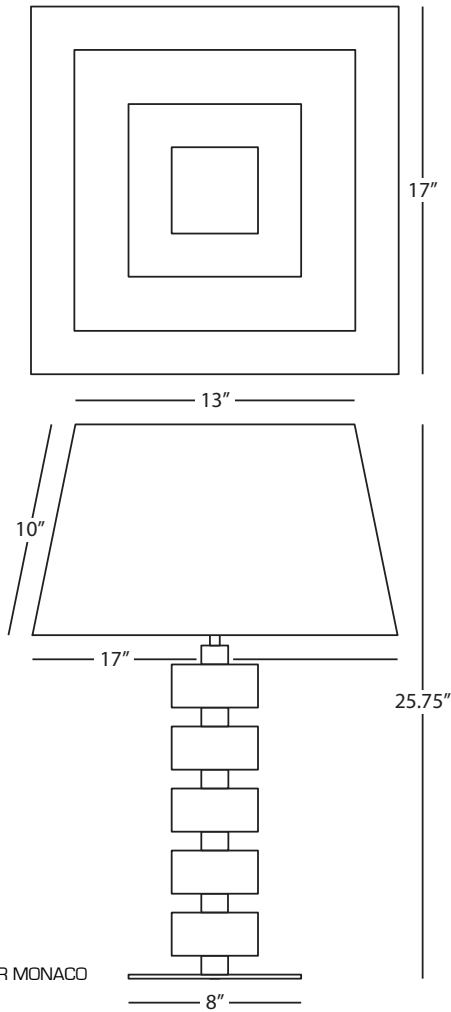

JONATHAN ADLER MONACO

175

Table Lamp

1 - 150W Max.
 Bulb Type: A
 Switch: Full Range Dimmer
 Polished Nickel Finish
 Clear Crystal Blocks
 Square, White Silk Shade

FINISH OPTIONS:

176 Lacquered, Natural Brass
 Turquoise Crystal
 Square, Off-White Silk Shade

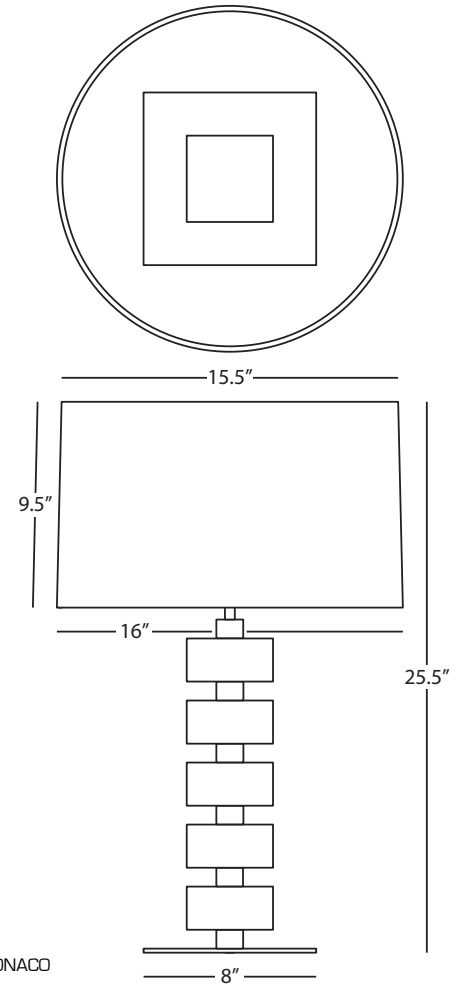

JONATHAN ADLER MONACO

176X

Table Lamp

1 - 150W Max.
 Bulb Type: A
 Switch: Full Range Dimmer
 Lacquered, Natural Brass
 Turquoise Crystal Blocks
 Round, Off-White Silk Shade w/
 Rolled Edge Hem

FINISH OPTIONS:

175X Polished Nickel
 Clear Crystal
 Round, White Silk Shade w/
 Rolled Edge Hem

Jonathan Adler Mykonos



157



S157

Jonathan Adler Mykonos

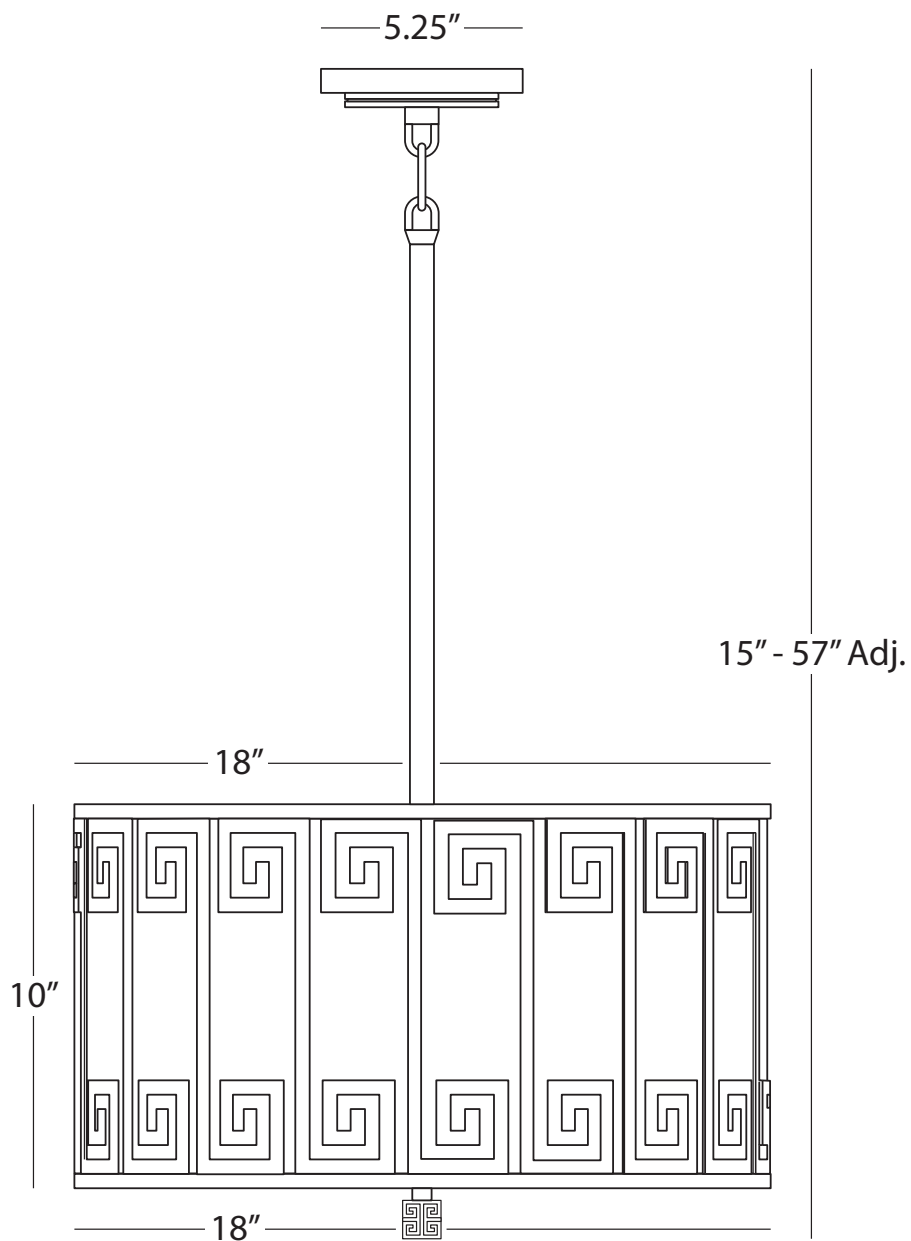

JONATHAN ADLER MYKONOS

157

Pendant

2 - 100W Max.
Bulb Type: A
Direct Wire
Modern Brass Finish
White Cotton Fabric Shade w/
White Acrylic Polished Diffuser
Susp. Hardware: 1 pc. 5/8" x 6" & 3 pcs.
5/8" x 12" Extensions

FINISH OPTION:

S157 Polished Nickel



639



S639

Jonathan Alder Parker

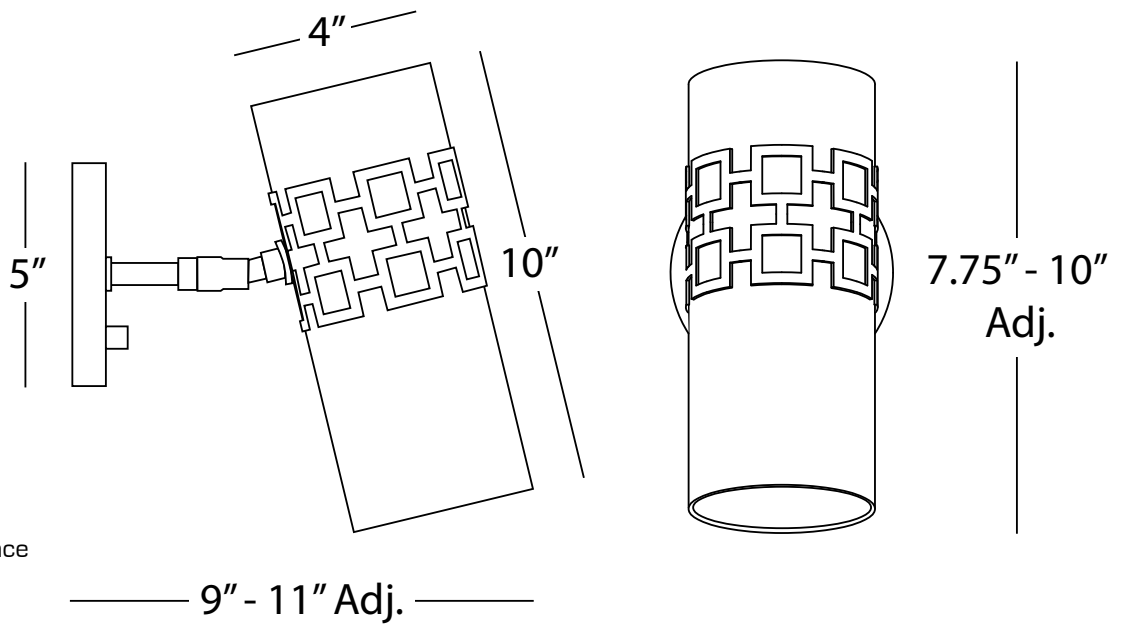

JONATHAN ADLER PARKER

639

Adjustable Wall Sconce

1 - 60W Max.
Bulb Type: G16.5 Candelabra
24" Cord Cover/Direct Wire
Antique Brass Finish
Frosted White Cased Glass Shade w/
Perforated Metal Detail

FINISH OPTIONS:

S639 Polished Nickel



S663



S664



Z662



667

Jonathan Adler Parker

JONATHAN ADLER PARKER

S664 Flush Mount

3 - 75W Max.
Bulb Type: A
Direct Wire Only
Polished Nickel Finish
Frosted White Cased Glass Shade
Perforated Metal Outer Shade

FINISH OPTIONS:

664 Antique Brass
Z664 Deep Patina Bronze

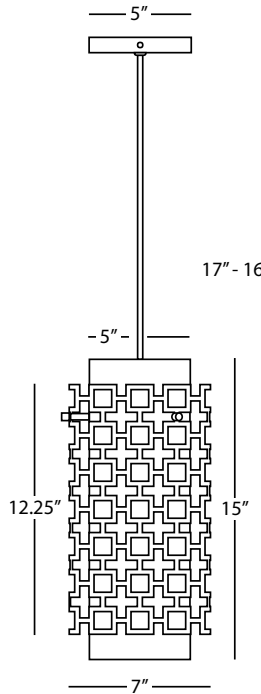
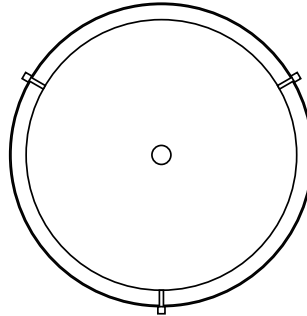
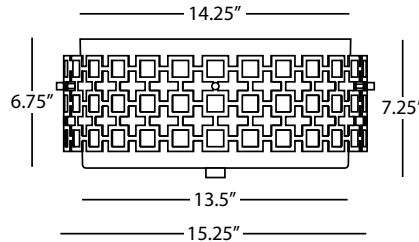

JONATHAN ADLER PARKER

S663 Pendant

1 - 60W Max.
Bulb Type: A
Direct Wire Only
Polished Nickel Finish
Frosted White Cased Glass Shade
Perforated Metal Outer Shade
Susp. Hardware: 12 Ft. Cord

FINISH OPTION:

663 Antique Brass

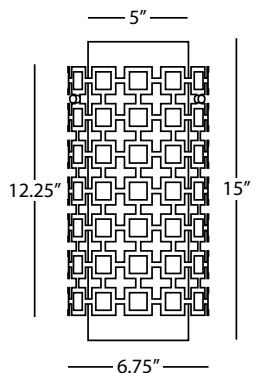

JONATHAN ADLER PARKER

Z662 Half Round Wall Sconce

1 - 60W Max.
Bulb Type: B, Candelabra
Direct Wire Only
Deep Patina Bronze Finish
Frosted White Cased Glass Shade
Perforated Metal Outer Shade
ADA Compliant

FINISH OPTIONS:

662 Antique Brass
S662 Polished Nickel

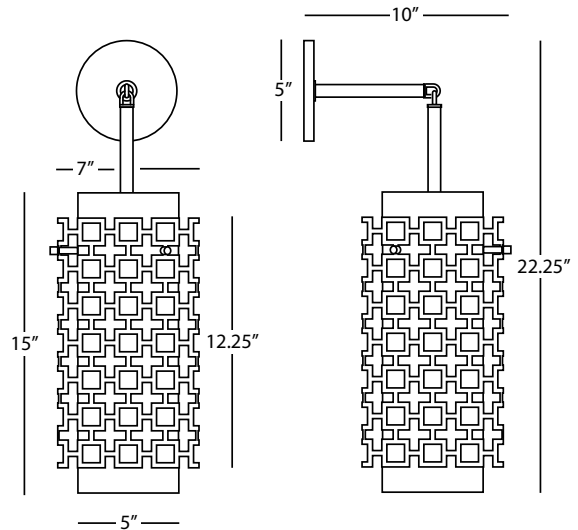

JONATHAN ADLER PARKER

667 Pendant Sconce

1 - 60W Max.
Bulb Type: A
Direct Wire Only
Antique Brass Finish
Frosted White Cased Glass Shade
Perforated Metal Outer Shade

FINISH OPTION:

S667 Polished Nickel

Jonathan Adler Rio



788



Z779



S792



792



777



S777



Z777

Jonathan Adler Rio

JONATHAN ADLER RIO

777

Wall Sconce

2 - 13W Max.
 Bulb Type: GU24 CFL
 Direct Wire Only
 Antique Brass Finish
 White Glass Shades
 UL Rated for Wet Locations

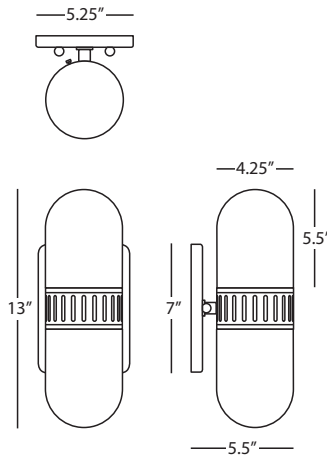

FINISH OPTIONS:

S777 Polished Nickel
Z777 Deep Patina Bronze

JONATHAN ADLER RIO

Z779

Pendant

1 - 13W Max.
 Bulb Type: GU24 CFL
 Direct Wire
 Deep Patina Bronze Finish
 White Glass Shade
 Susp. Hardware: 12 Ft. Black Cord
 UL Rated for Damp Locations

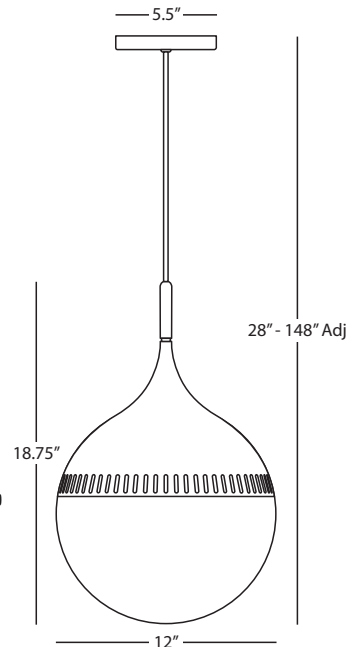

FINISH OPTIONS:

779 Antique Brass
S779 Polished Nickel

JONATHAN ADLER RIO

788

Floor Lamp

6 - 40W Max.
 Bulb Type: B, Medium Base
 Switch: Full Range Dimmer Line Switch
 Antique Brass Finish
 White Glass Shades

FINISH OPTION:

S788 Polished Nickel

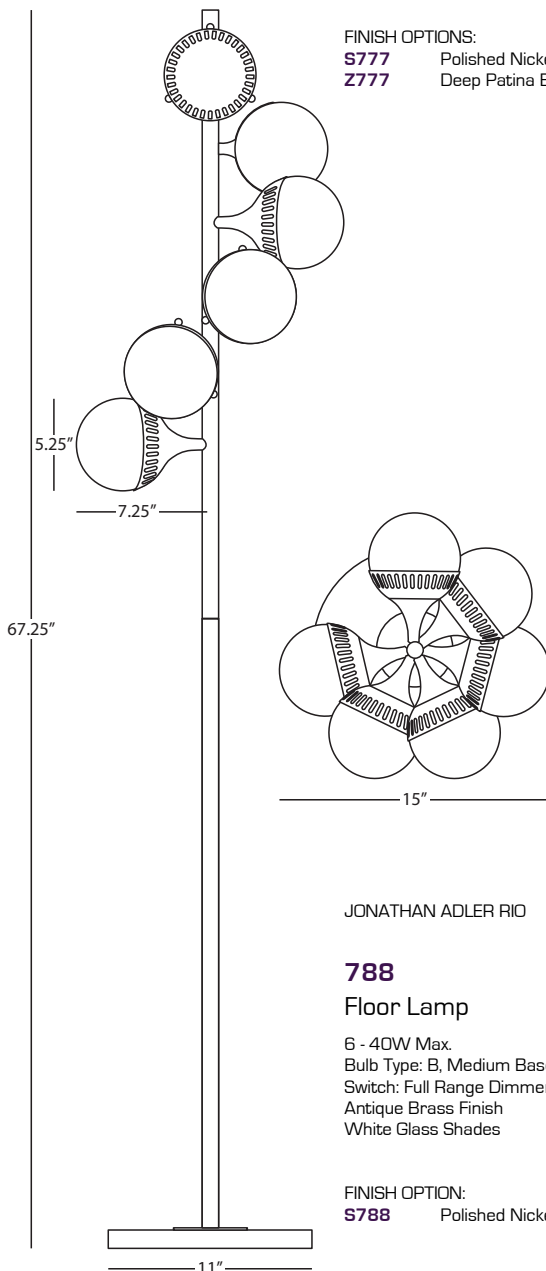

JONATHAN ADLER RIO

792

Small Pendant

1 - 40W Max.
 Bulb Type: A
 Direct Wire
 Antique Brass Finish
 White Glass Shade
 Susp. Hardware: 12 Ft. Black Fabric
 Wrapped Cord

FINISH OPTIONS:

S792 Polished Nickel
Z792 Deep Patina Bronze

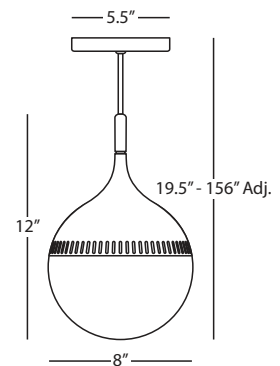



Jonathan Adler Rio

JONATHAN ADLER RIO

791

Multi-Globe Chandelier

3 - 40W Max. & 2 - 60W Max.
Bulb Type: A
Direct Wire
Antique Brass Finish
White Glass Shades
Susp. Hardware: 5 pcs. 11 Ft. Black
Fabric Wrapped Cord

NOTE: Globes can be arranged in in any configuration the customer desires. The shortest drop possible is 30". The greatest drop possible is 136".

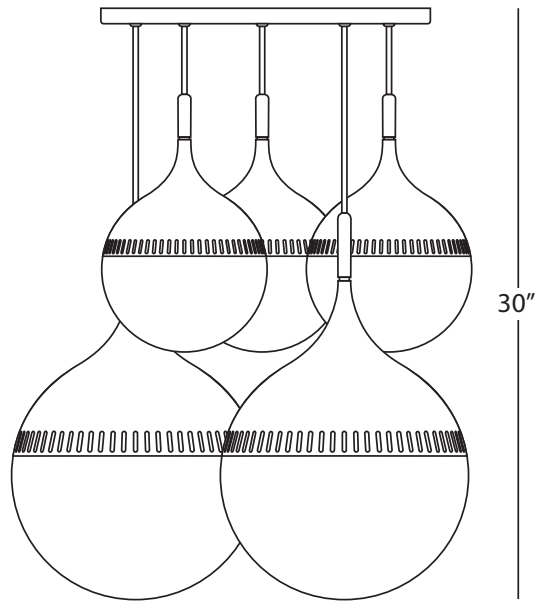

MINIMUM DROP GLOBE CONFIGURATION

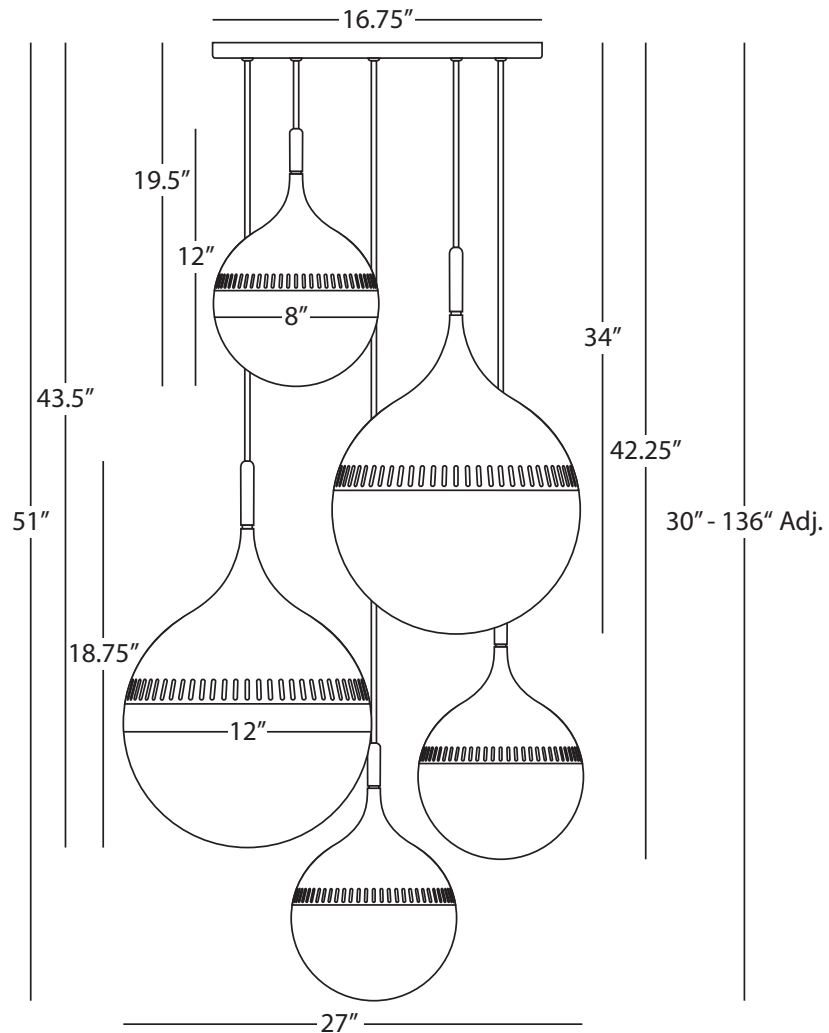

AS PHOTOGRAPHED



780



S780

Jonathan Adler Rio

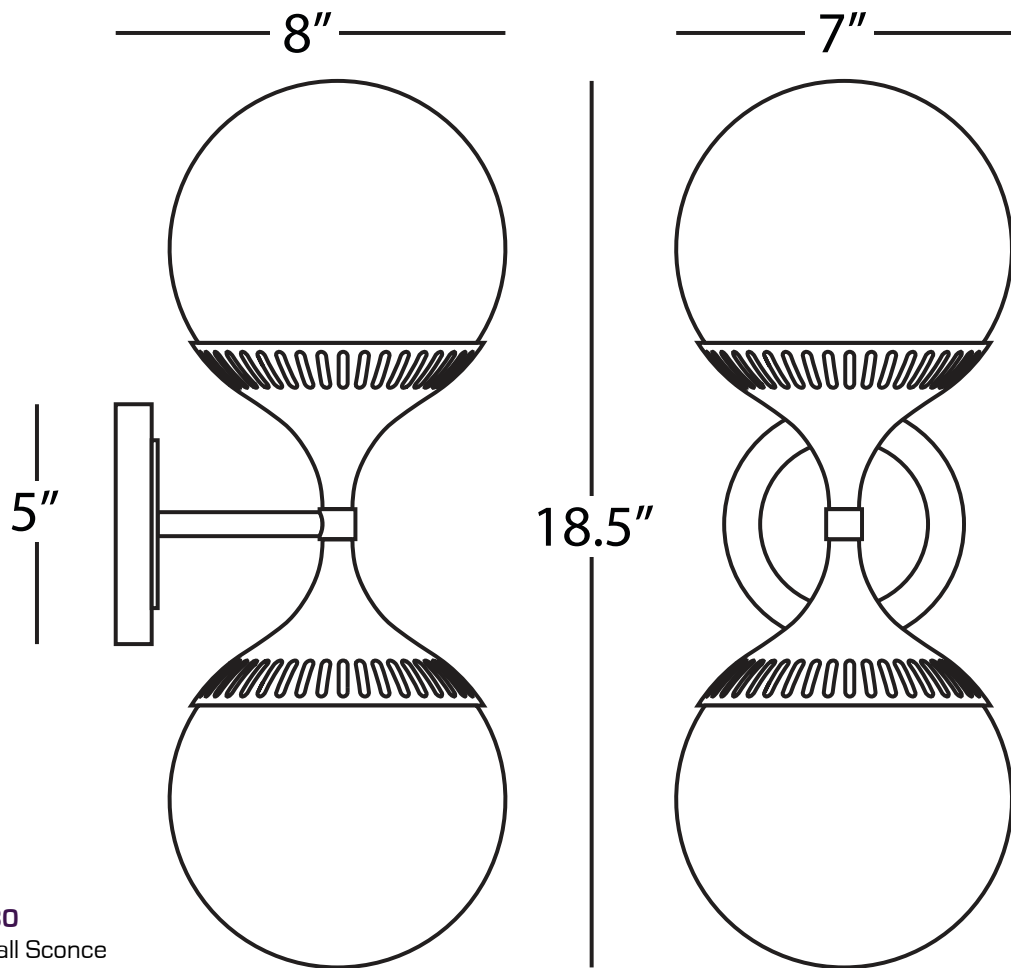

Rio

780

Wall Sconce

2 - 60W Max.

Bulb Type: A

24" Cord Cover/Direct Wire

Switch: On/Off Line Switch

Modern Brass Finish

Cased White Glass Shades

FINISH OPTIONS:

S780 Polished Nickel/Cased White Glass

Jonathan Adler Rio



756



S758



759



S767

Jonathan Adler Rio

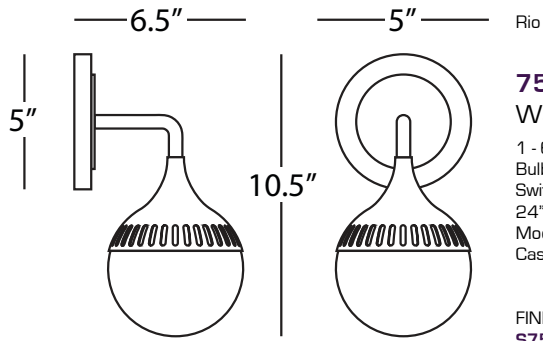

Rio
756
 Wall Sconce
 1 - 60W Max.
 Bulb Type: B (Medium Base)
 Switch: On/Off Line Switch
 24" Cord Cover/Direct Wire
 Modern Brass Finish
 Cased White Glass Shade

FINISH OPTIONS:
S756 Polished Nickel

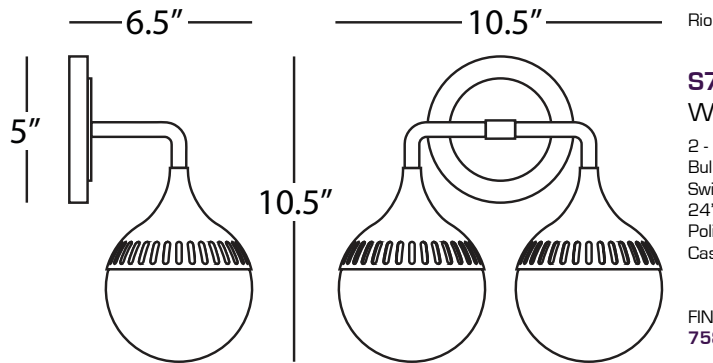

Rio
S758
 Wall Sconce
 2 - 60W Max.
 Bulb Type: B (Medium Base)
 Switch: On/Off Line Switch
 24" Cord Cover/Direct Wire
 Polished Nickel Finish
 Cased White Glass Shades

FINISH OPTIONS:
758 Modern Brass

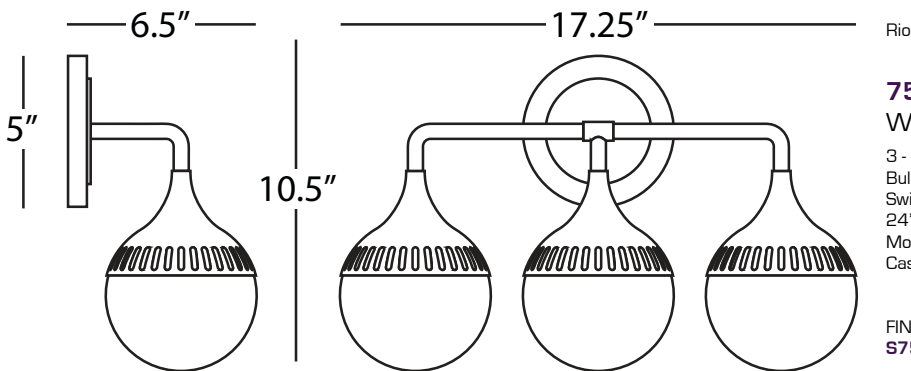

Rio
759
 Wall Sconce
 3 - 60W Max.
 Bulb Type: B (Medium Base)
 Switch: On/Off Line Switch
 24" Cord Cover/Direct Wire
 Modern Brass Finish
 Cased White Glass Shades

FINISH OPTIONS:
S759 Polished Nickel

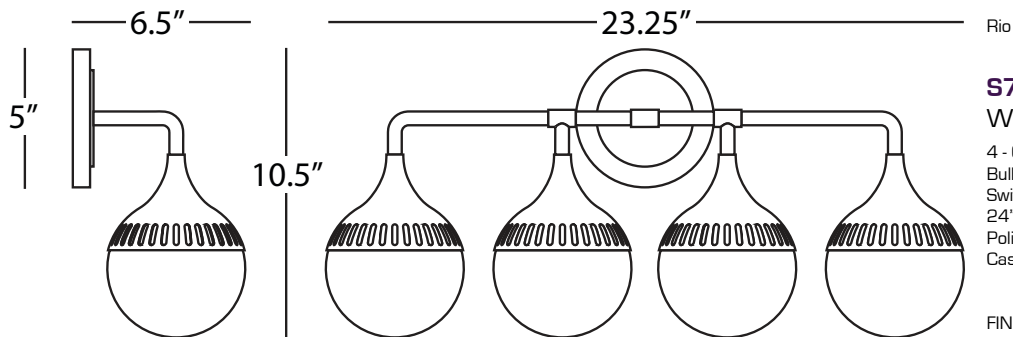

Rio
S767
 Wall Sconce
 4 - 60W Max.
 Bulb Type: B (Medium Base)
 Switch: On/Off Line Switch
 24" Cord Cover/Direct Wire
 Polished Nickel Finish
 Cased White Glass Shades

FINISH OPTIONS:
767 Modern Brass



S778



778

Jonathan Adler Rio

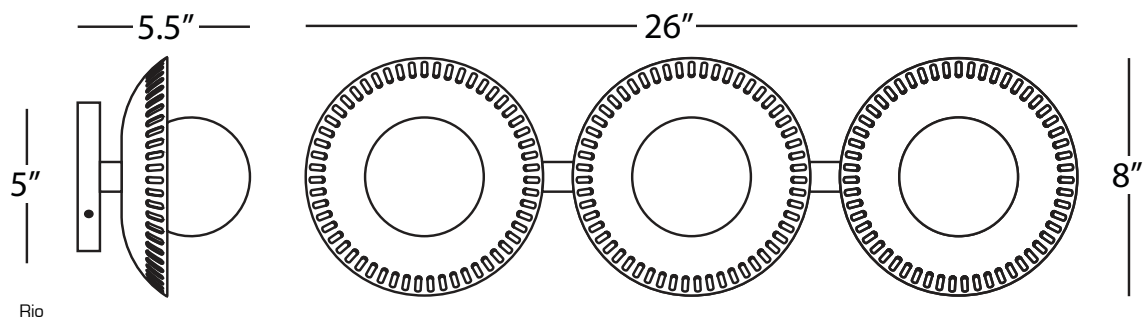

Rio

S778

Wall Sconce

3 - 4W Max.
Bulb Type: 120V G9 Bi-Pin LED
Switch: On/Off Line Switch
24" Cord Cover/Direct Wire
Polished Nickel Finish
Cased White Glass Shades

FINISH OPTIONS:

778 Modern Brass



635



B635



T635



W635

Jonathan Adler Rio

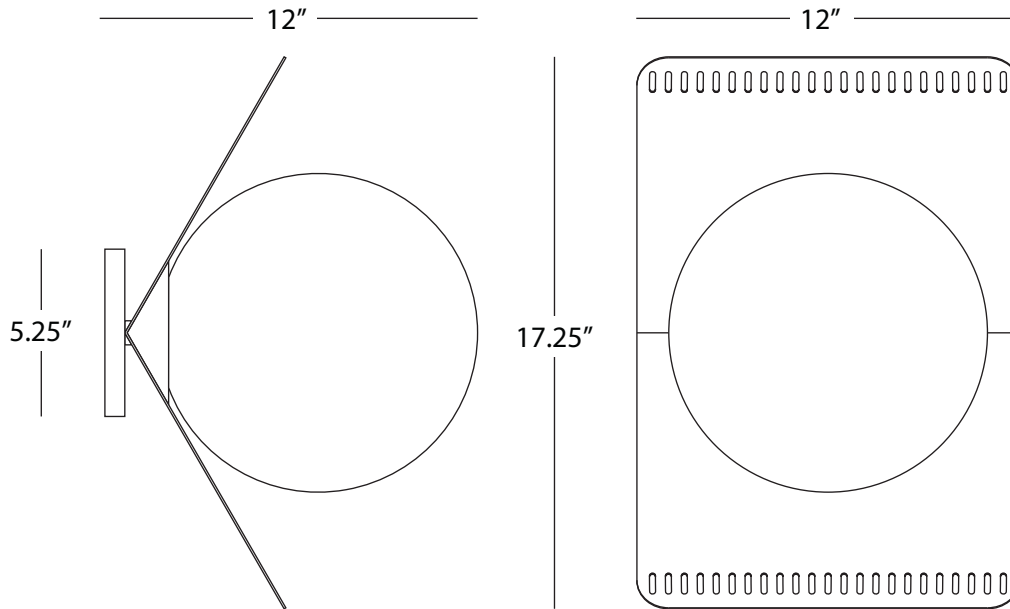

JONATHAN ADLER RIO

W635

Wall Sconce

1 - 60W Max.
Bulb Type: A
Direct Wire Only
Satin White Powder Coat
Cased White Glass Shade
UL Rated Damp Locations

FINISH OPTIONS:

635 Modern Brass Finish
B635 Satin Black Powder Coat
T635 Tangerine Gloss Powder Coat



776

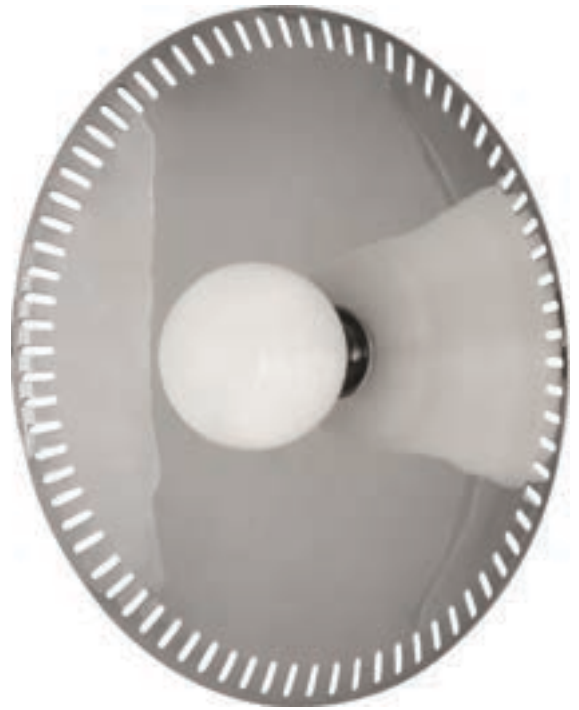

S776

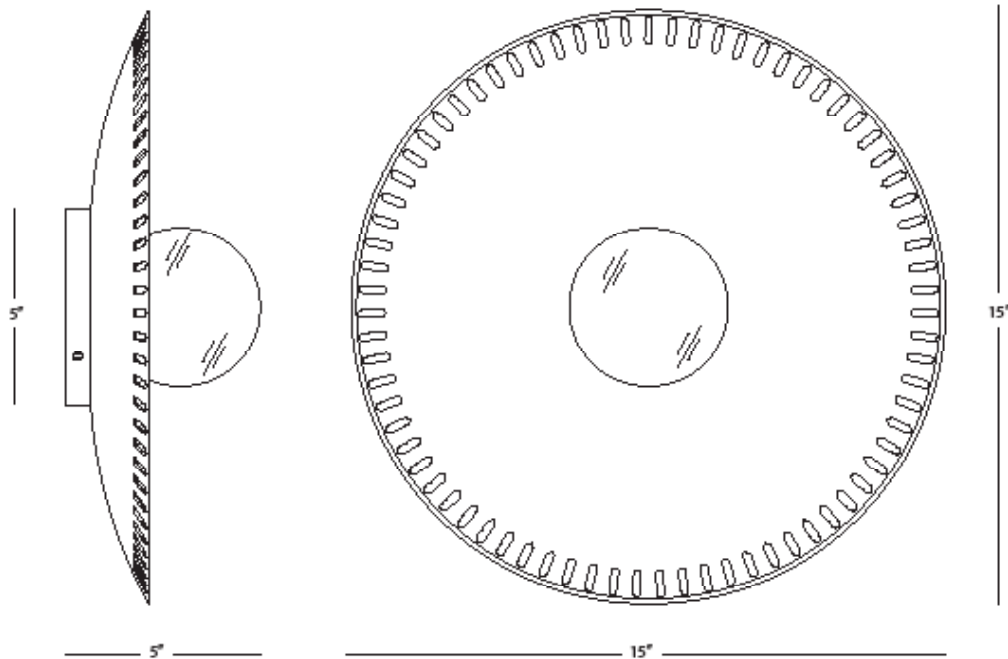

JONATHAN ADLER RIO

776 Wall Sconce

1 - 4W Max.
Bulb Type: 120V G9 Bi-Pin LED
Switch: On-Off Line Switch
24" Cord Cover/Direct Wire
Modern Brass Finish
White Glass Shade
UL Rated Damp Locations

FINISH OPTIONS:
S776 Polished Nickel

Jonathan Adler Saturn



R911



L910



R910G



L911B

Jonathan Adler Saturn

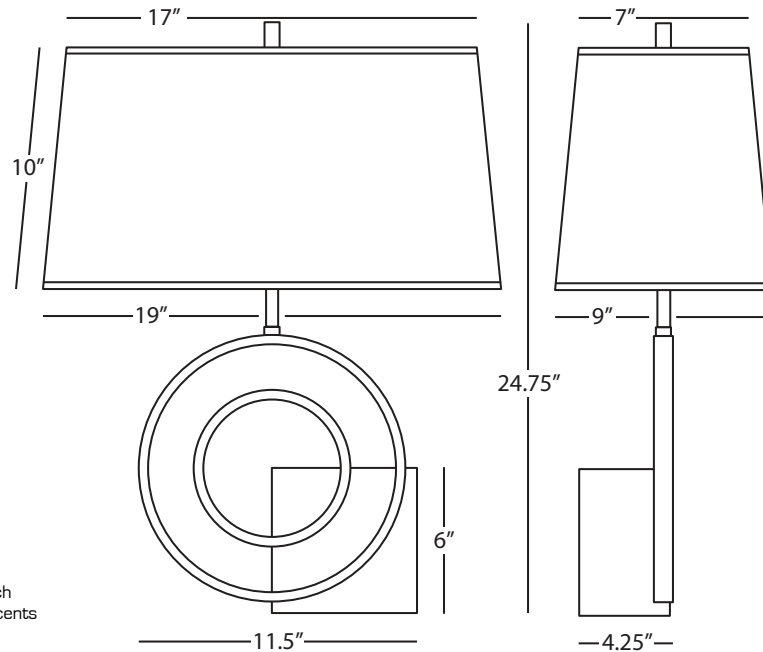

JONATHAN ADLER SATURN

L910

Left Facing Table Lamp

2 - 100W Max.
 Bulb Type: A
 Switch: Full Range Dimmer Line Switch
 White Marble w/ Polished Nickel Accents
 Rectangular Oyster Linen Shade

FINISH/SHADE OPTIONS:

- L910G** White Marble/Polished Nickel w/ Smoke Gray Shade
- L911** Black Marble/Antique Brass w/ Oyster Linen Shade
- L911B** Black Marble/Antique Brass w/ Black Parchment Shade w/ White Lining

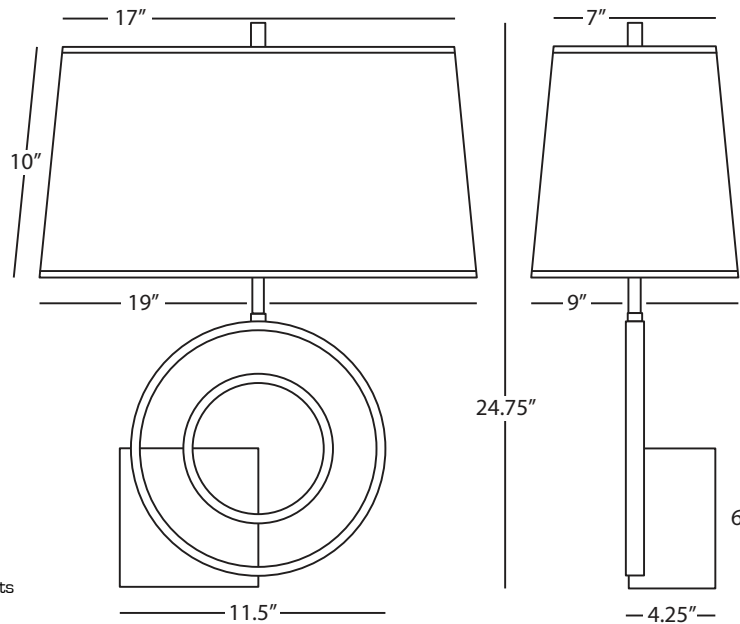

JONATHAN ADLER SATURN

R910G

Right Facing Table Lamp

2 - 100W Max.
 Bulb Type: A
 Switch: Full Range Dimmer Line Switch
 White Marble w/ Polished Nickel Accents
 Rectangular Smoke Gray Fabric Shade

FINISH/SHADE OPTIONS:

- R910** White Marble/Polished Nickel w/ Oyster Linen Shade
- R911** Black Marble/Antique Brass w/ Oyster Linen Shade
- R911B** Black Marble/Antique Brass w/ Black Parchment Shade w/ White Lining



711



S710



714

Jonathan Adler Sputnik

JONATHAN ADLER SPUTNIK

JONATHAN ADLER SPUTNIK

711

Flush Mount/Sconce

12 - 40W Max.
Bulb Type: G16.5 Candelabra
Direct Wire Only
Antique Brass Finish w/
Crystal Accents

FINISH OPTION:

S711 Polished Nickel

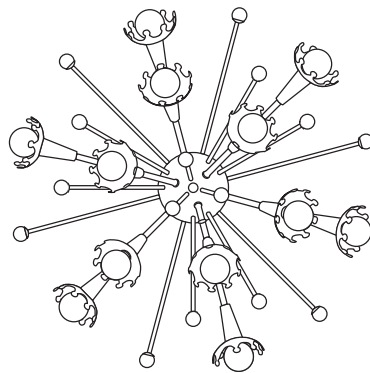
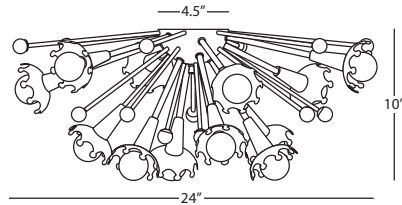

S710

Chandelier

24 - 40W Max.
Bulb Type: G16.5 Candelabra
Direct Wire
Polished Nickel Finish w/
Crystal Accents
Susp. Hardware: 3 pcs. 1/2" x
12" & 1 pc. 1/2" x 6" Extensions

FINISH OPTION:

710 Antique Brass

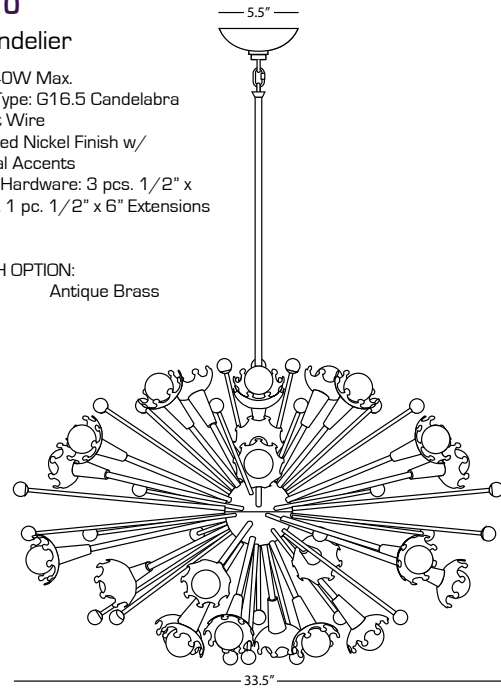

JONATHAN ADLER SPUTNIK

714

Large Chandelier

24 - 40W Max.
Bulb Type: G16.5 Candelabra
Direct Wire
Antique Brass Finish w/
Clear Crystal Accents
Susp. Hardware: 3 pcs. 5/8" x 12"
& 1 pc. 5/8" x 6" Extensions

FINISH OPTION:

S714 Polished Nickel

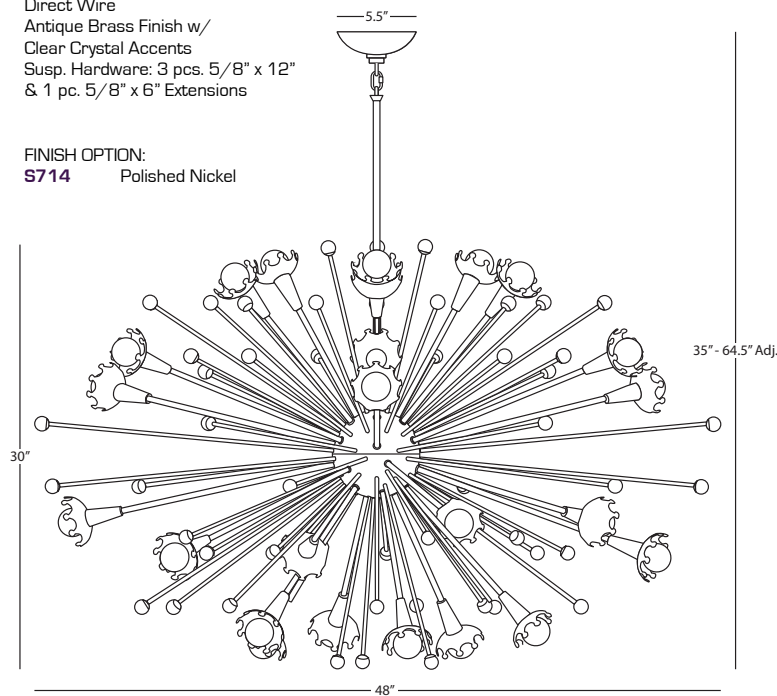

Jonathan Adler Totem



237G



237



238



238B

Jonathan Adler Totem

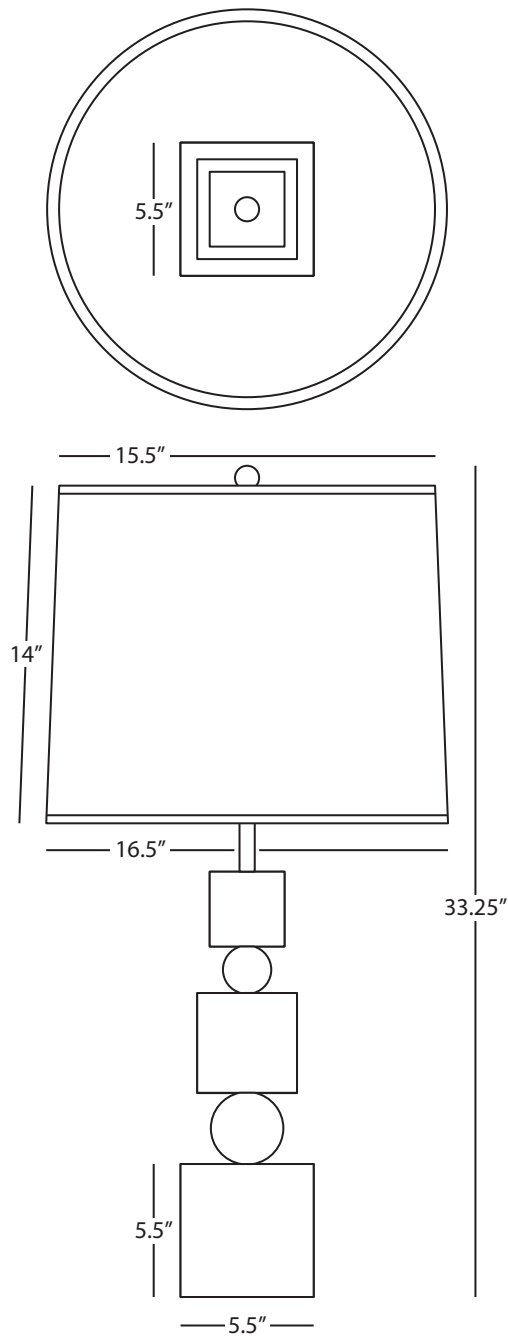

JONATHAN ADLER TOTEM

237

Table Lamp

1 - 150W Max.

Bulb Type: A

Switch: Full Range Dimmer

White Marble w/ Modern Brass Accents

Oyster Linen Fabric Shade

FINISH/SHADE OPTIONS:

237G White Marble/Smoke Gray Fabric

238 Black Marble/Oyster Linen

238B Black Marble/Black Opaque Parchment w/ White Lining



PN671



672



WH672



WH770



AW771

Jonathan Adler Ventana

JONATHAN ADLER VENTANA

672

Wall Sconce

1 - 60W Max.
 Bulb Type: G16.5 Candelabra
 Switch: Hi-Lo Dimming
 24" Cord Cover/Direct Wire
 Ebony Finished Wood w/
 Antique Brass Accents
 Oval, Natural Linen Shade w/ Rolled Edge Hem

FINISH/SHADE OPTIONS:

- AW672** White Wood w/ Polished Nickel Accents
Ascot White
- PN672** Ebony Wood w/ Polished Nickel Accents
Natural Linen w/ Rolled Edge Hem
- WH672** White Wood w/ Polished Nickel Accents
Dark Gray Cotton w/ Rolled Edge Hem

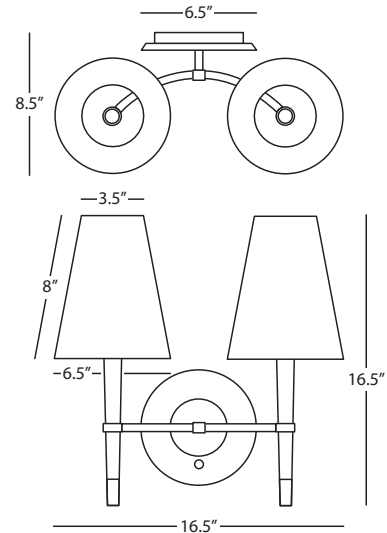
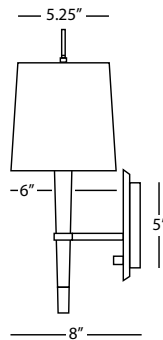
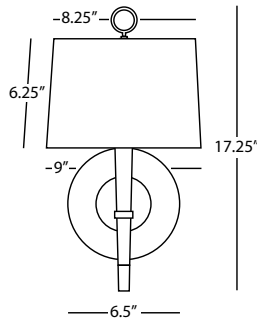

JONATHAN ADLER VENTANA

AW771

Double Sconce

2 - 60W Max.
 Bulb Type: B, Candelabra
 Switch: Hi-Lo Dimming
 24" Cord Cover/Direct Wire
 White Finished Wood w/ Polished Nickel Accents
 Ascot White Shades

FINISH/SHADE OPTIONS:

- 771** Ebony Wood w/ Antique Brass Accents
Natural Linen w/ Rolled Edge Hem
- PN771** Ebony Wood w/ Polished Nickel Accents
Natural Linen w/ Rolled Edge Hem
- WH771** White Wood w/ Polished Nickel Accents
Dark Gray Cotton w/ Rolled Edge Hem

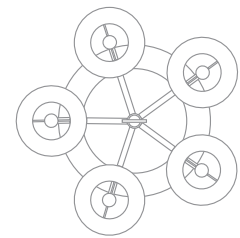

JONATHAN ADLER VENTANA

PN671

Tripod Floor Lamp

1 - 150W Max.
 Bulb Type: A
 Switch: 3-Way Pull Chain
 Ebony Finished Wood w/
 Polished Nickel Accents
 Natural Linen Shade w/
 Rolled Edge Hem

FINISH/SHADE OPTIONS:

- 671** Ebony Wood w/ Antique Brass Accents
Natural Linen w/ Rolled Edge Hem
- AW671** White Wood w/ Polished Nickel Accents
Ascot White
- WH671** White Wood w/ Polished Nickel Accents
Dark Gray Cotton w/ Rolled Edge Hem

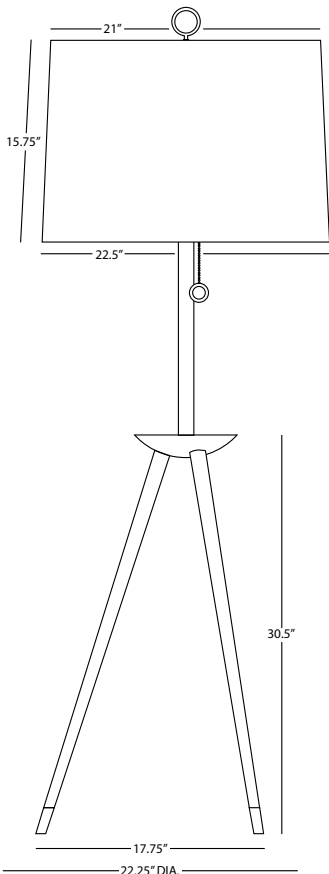

JONATHAN ADLER VENTANA

WH770

Spiral Floor Lamp

5 - 40W Max.
 Bulb Type: B10 Candelabra
 Switch: On-Off Foot Switch
 White Finished Wood w/
 Polished Nickel Accents
 Dark Gray Cotton Shades w/
 Rolled Edge Hem

FINISH/SHADE OPTION:

- AW770** White Wood w/ Polished Nickel Accents
Ascot White

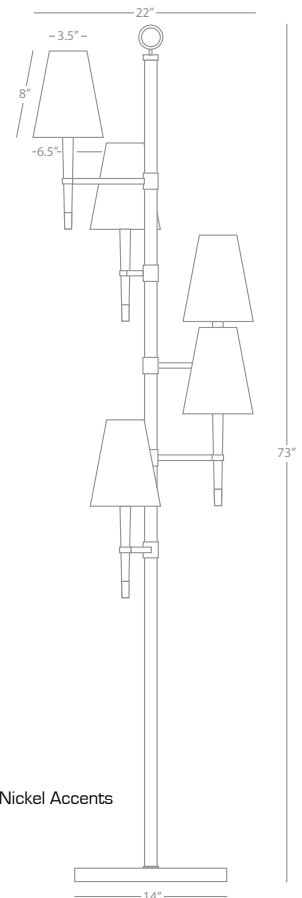



673



PN674

Jonathan Adler Ventana

JONATHAN ADLER VENTANA

673 2-Tier, 8-Light Chandelier

8 - 25W Max.
Bulb Type: B, Candelabra
Direct Wire Only
Ebony Finished Wood w/
Antique Brass Finished Accents
Natural Linen Shades w/ Rolled Edge Hem
Susp. Hardware: 3 pcs. 5/8" x 12"
& 1 pc. 5/8" x 6" Extensions

FINISH/SHADE OPTIONS:

AW673 White Wood w/ Polished Nickel Accents
Ascot White
PN673 Ebony Wood w/ Polished Nickel Accents
Natural Linen w/ Rolled Edge Hem
WH673 White Wood w/ Polished Nickel Accents
Dark Gray Cotton w/ Rolled Edge Hem

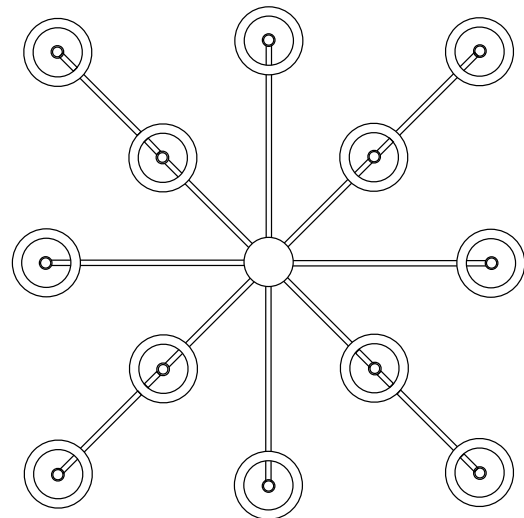
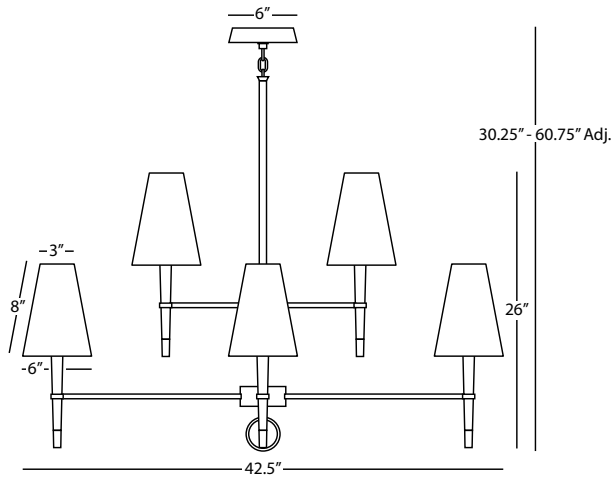
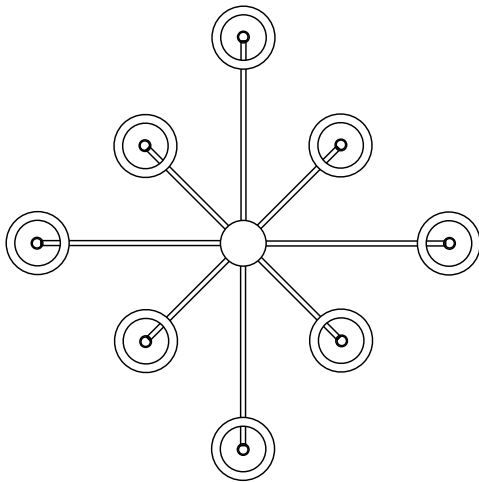

JONATHAN ADLER VENTANA

PN674 3-Tier, 12-Light Chandelier

12 - 25W Max.
Bulb Type: B, Candelabra
Direct Wire Only
Ebony Finished Wood w/ Polished Nickel Finished Accents
Natural Linen Shades w/ Rolled Edge Hem
Susp. Hardware: 3 pcs. 5/8" x 12"
& 1 pc. 5/8" x 6" Extensions

FINISH/SHADE OPTIONS:

674 Ebony Wood w/ Antique Brass Accents
Natural Linen w/ Rolled Edge Hem

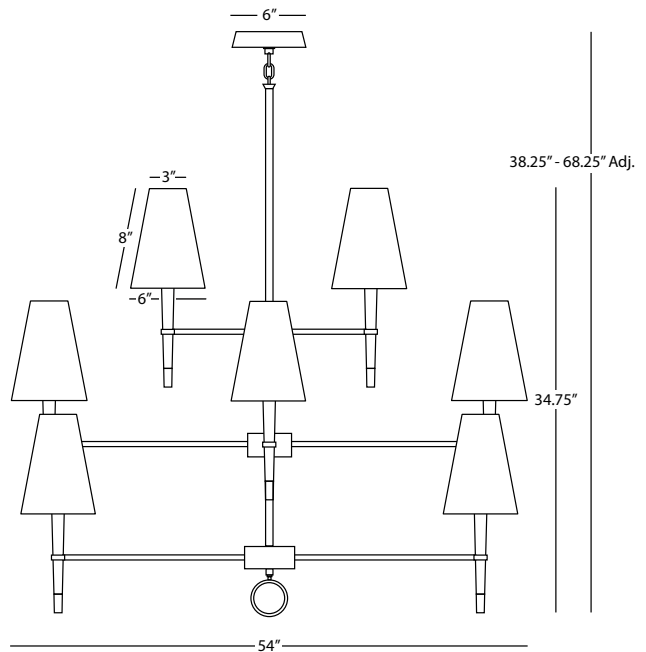

Jonathan Adler Ventana



PN685



AW718

Jonathan Adler Ventana

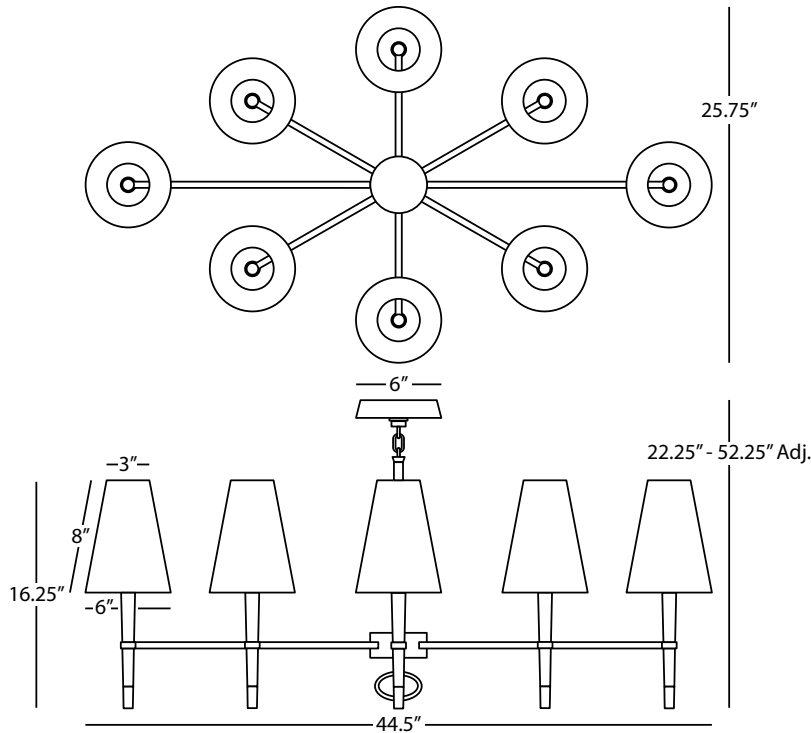

JONATHAN ADLER VENTANA

AW718 Oval Chandelier

8 - 25W Max.
Bulb Type: B, Candelabra
Direct Wire
White Finished Wood w/ Polished Finished Accents
Ascot White Shades
Susp. Hardware: 3 pcs. 5/8" x 12" &
1 pc. 5/8" x 6" Extensions

FINISH/SHADE OPTIONS:

- 718** Ebony Wood w/ Antique Brass Accents
Natural Linen w/ Rolled Edge Hem
- PN718** Ebony Wood w/ Polished Nickel Accents
Natural Linen w/ Rolled Edge Hem
- WH718** White Wood w/ Polished Nickel Accents
Dark Gray Cotton Shades w/ Rolled Edge Hem

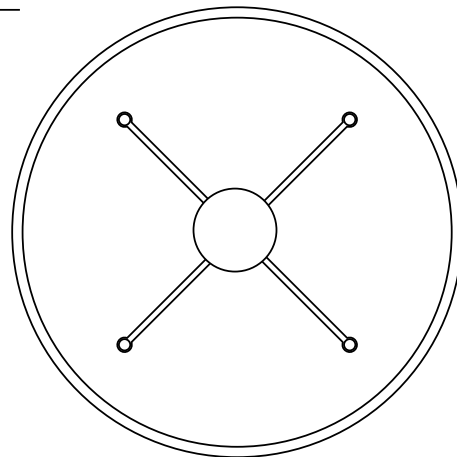

JONATHAN ADLER VENTANA

PN685 Single Shade Chandelier

4 - 60W Max.
Bulb Type: B, Candelabra
Direct Wire Only
Ebony Finished Wood w/
Polished Nickel Accents
Natural Linen Shade w/ Rolled Edge Hem
Susp. Hardware: 3 pcs. 5/8" x 12"
& 1 pc. 5/8" x 6" Extensions

FINISH/SHADE OPTIONS:

- 685** Antique Brass Accents

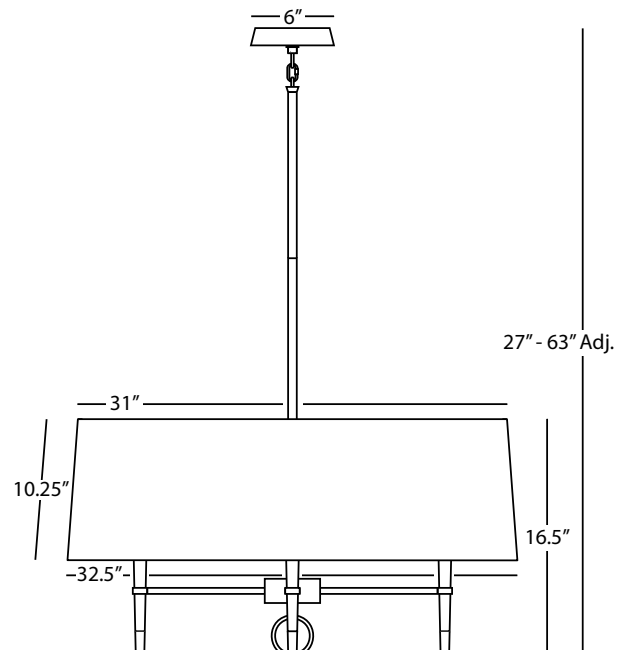

Jonathan Adler Versailles



C901



W900



B901



A900X



G900X

Jonathan Adler Versailles

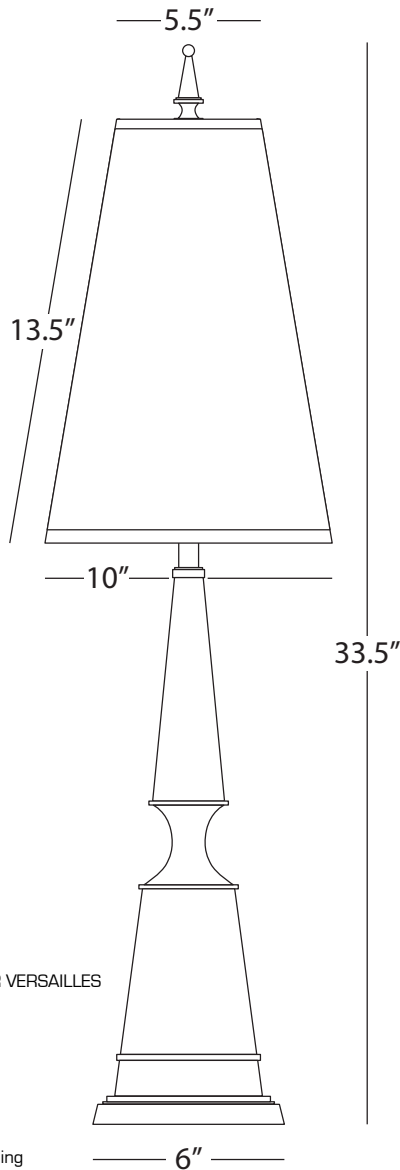

JONATHAN ADLER VERSAILLES

C901

Table Lamp

1 - 100W Max.
 Bulb Type: A
 Switch: Hi-Lo Dimming
 Navy Lacquered Paint
 Modern Brass Accents
 Navy Painted Opaque Parchment Shade
 w/ Matte Gold Lining

FINISH/SHADE OPTIONS:

- A901** Ash Lacquer/Modern Brass
- Ash Painted Parchment w/ Matte Gold Lining
- A901X** Ash Lacquer/Modern Brass
- Fondine Fabric
- B901** Black Lacquer/Modern Brass
- Black Painted Parchment w/ Matte Gold Lining
- B901X** Black Lacquer/Modern Brass
- Fondine Fabric
- C901X** Navy Lacquer/Modern Brass
- Fondine Fabric
- G901** Emerald Lacquer/Modern Brass
- Emerald Painted Parchment w/ Matte Gold Lining
- G901X** Emerald Lacquer/Modern Brass
- Fondine Fabric
- W901** Lily Lacquer/Modern Brass
- Lily Painted Parchment w/ Matte Gold Lining
- W901X** Lily Lacquer/Modern Brass
- Fondine Fabric

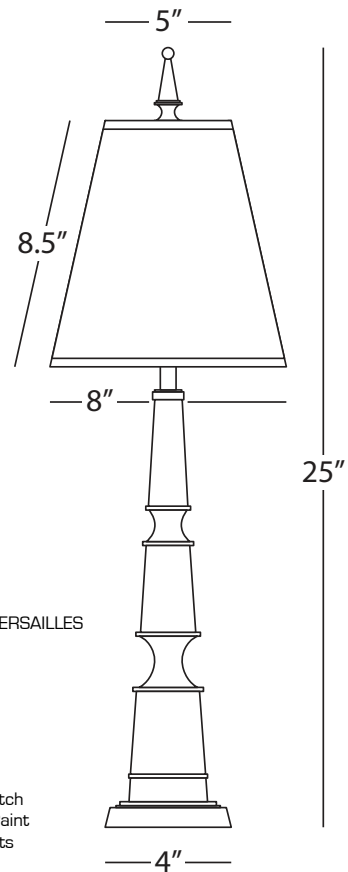

JONATHAN ADLER VERSAILLES

G900X

Buffet Lamp

1 - 60W Max.
 Bulb Type: A
 Switch: Hi-Lo Line Switch
 Emerald Lacquered Paint
 Modern Brass Accents
 Fondine Fabric Shade

FINISH/SHADE OPTIONS:

- A900** Ash Lacquer/Modern Brass
- Ash Painted Parchment w/ Matte Gold Lining
- A900X** Ash Lacquer/Modern Brass
- Fondine Fabric
- B900** Black Lacquer/Modern Brass
- Black Painted Parchment w/ Matte Gold Lining
- B900X** Black Lacquer/Modern Brass
- Fondine Fabric
- C900** Navy Lacquer/Modern Brass
- Navy Painted Parchment w/ Matte Gold Lining
- C900X** Navy Lacquer/Modern Brass
- Fondine Fabric
- G900** Emerald Lacquer/Modern Brass
- Emerald Painted Parchment w/ Matte Gold Lining
- W900** Lily Lacquer/Modern Brass
- Lily Painted Parchment w/ Matte Gold Lining
- W900X** Lily Lacquer/Modern Brass
- Fondine Fabric

Jonathan Adler Versailles



W904



A604X



B904



C604X

Jonathan Adler Versailles

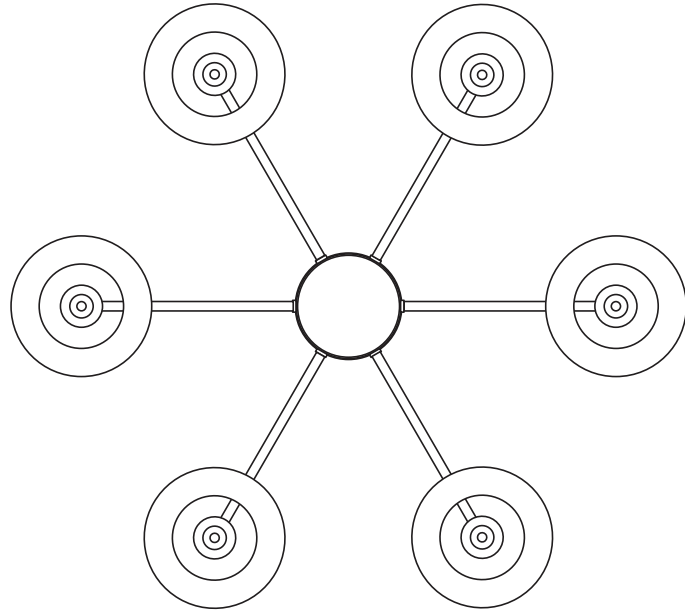

JONATHAN ADLER VERSAILLES

W904

Chandelier

6 - 60W Max.
 Bulb Type: B, Candelabra
 Direct Wire
 Lily Lacquered Paint
 Modern Brass Accents
 Lily Painted Opaque Parchment Shades
 w/ Matte Gold Lining
 Susp. Hardware: 1 pc. 5/8" x 6" & 3 pcs. 5/8" x 12" Extensions

FINISH/SHADE OPTIONS:

- A604** Ash Lacquer/Polished Nickel
- Ash Painted Parchment w/ Matte Silver Lining
- A604X** Ash Lacquer/Polished Nickel
- Fondine Fabric
- A904** Ash Lacquer/Modern Brass
- Ash Painted Parchment w/ Matte Gold Lining
- A904X** Ash Lacquer/Modern Brass
- Fondine Fabric
- B604** Black Lacquer/Polished Nickel
- Black Painted Parchment w/ Matte Silver Lining
- B604X** Black Lacquer/Polished Nickel
- Fondine Fabric
- B904** Black Lacquer/Modern Brass
- Black Painted Parchment w/ Matte Gold Lining
- B904X** Black Lacquer/Modern Brass
- Fondine Fabric
- C604** Navy Lacquer/Polished Nickel
- Navy Painted Parchment w/ Matte Silver Lining
- C604X** Navy Lacquer/Polished Nickel
- Fondine Fabric
- C904** Navy Lacquer/Modern Brass
- Navy Painted Parchment w/ Matte Gold Lining
- C904X** Navy Lacquer/Modern Brass
- Fondine Fabric
- G604** Emerald Lacquer/Polished Nickel
- Emerald Painted Parchment w/ Matte Silver Lining
- G604X** Emerald Lacquer/Polished Nickel
- Fondine Fabric
- G904** Emerald Lacquer/Modern Brass
- Emerald Painted Parchment w/ Matte Gold Lining
- G904X** Emerald Lacquer/Modern Brass
- Fondine Fabric
- W604** Lily Lacquer/Polished Nickel
- Lily Painted Parchment w/ Matte Silver Lining
- W604X** Lily Lacquer/Polished Nickel
- Fondine Fabric
- W904X** Lily Lacquer/Modern Brass
- Fondine Fabric

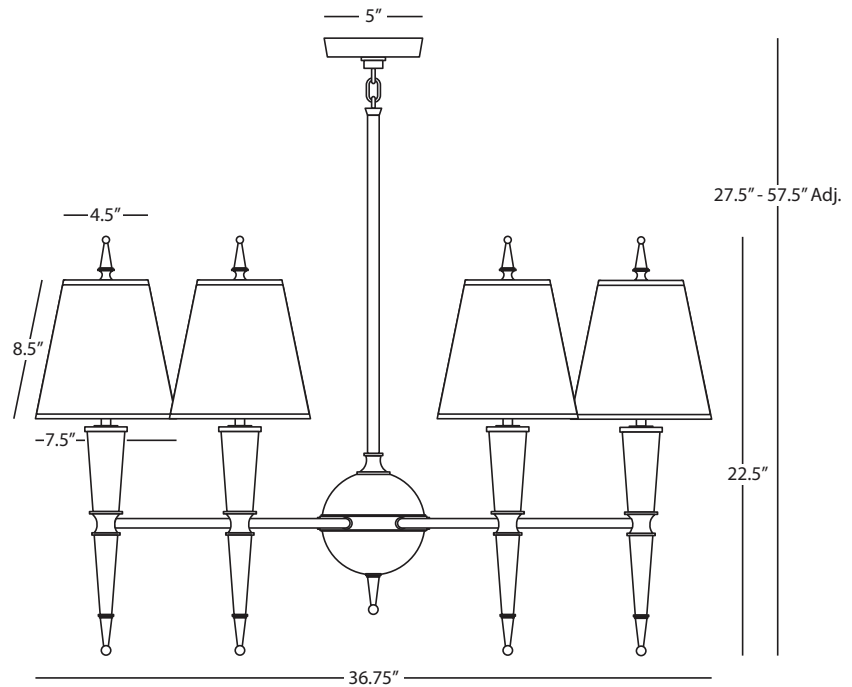

Jonathan Adler Versailles



A902X



B903



W603



G902

Jonathan Adler Versailles

JONATHAN ADLER VERSAILLES

B903

Wall Sconce

1 - 60W Max.
 Bulb Type: B, Candelabra
 Switch: Hi-Lo Dimming
 24" Cord Cover/Direct Wire
 Black Lacquered Paint
 Modern Brass Accents
 Black Painted Opaque Parchment Shade
 w/ Matte Gold Lining

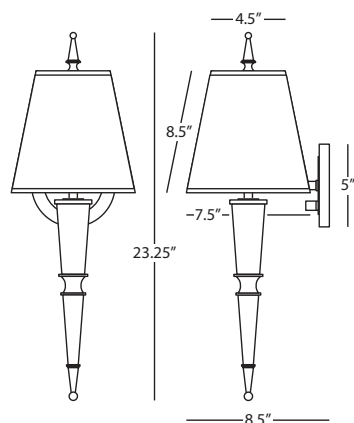

FINISH/SHADE OPTIONS:

- A603** Ash Lacquer/Polished Nickel
Ash Painted Parchment w/ Matte Silver Lining
- A603X** Ash Lacquer/Polished Nickel
Fondine Fabric
- A903** Ash Lacquer/Modern Brass
Ash Painted Parchment w/ Matte Gold Lining
- A903X** Ash Lacquer/Modern Brass
Fondine Fabric
- B603** Black Lacquer/Polished Nickel
Black Painted Parchment w/ Matte Silver Lining
- B603X** Black Lacquer/Polished Nickel
Fondine Fabric
- B903X** Black Lacquer/Modern Brass
Fondine Fabric
- C603** Navy Lacquer/Polished Nickel
Navy Painted Parchment w/ Matte Silver Lining
- C603X** Navy Lacquer/Polished Nickel
Fondine Fabric
- C903** Navy Lacquer/Modern Brass
Navy Painted Parchment w/ Matte Gold Lining
- C903X** Navy Lacquer/Modern Brass
Fondine Fabric
- G603** Emerald Lacquer/Polished Nickel
Emerald Painted Parchment w/ Matte Silver Lining
- G603X** Emerald Lacquer/Polished Nickel
Fondine Fabric
- G903** Emerald Lacquer/Modern Brass
Emerald Painted Parchment w/ Matte Gold Lining
- G903X** Emerald Lacquer/Modern Brass
Fondine Fabric
- W603** Lily Lacquer/Polished Nickel
Lily Painted Parchment w/ Matte Silver Lining
- W603X** Lily Lacquer/Polished Nickel
Fondine Fabric
- W903** Lily Lacquer/Modern Brass
Lily Painted Parchment w/ Matte Gold Lining
- W903X** Lily Lacquer/Modern Brass
Fondine Fabric

JONATHAN ADLER VERSAILLES

A902X

Floor Lamp

1 - 150W Max.
 Bulb Type: A
 Switch: Hi-Lo Dimming
 Ash Lacquered Paint
 Modern Brass Accents
 Fondine Fabric Shade

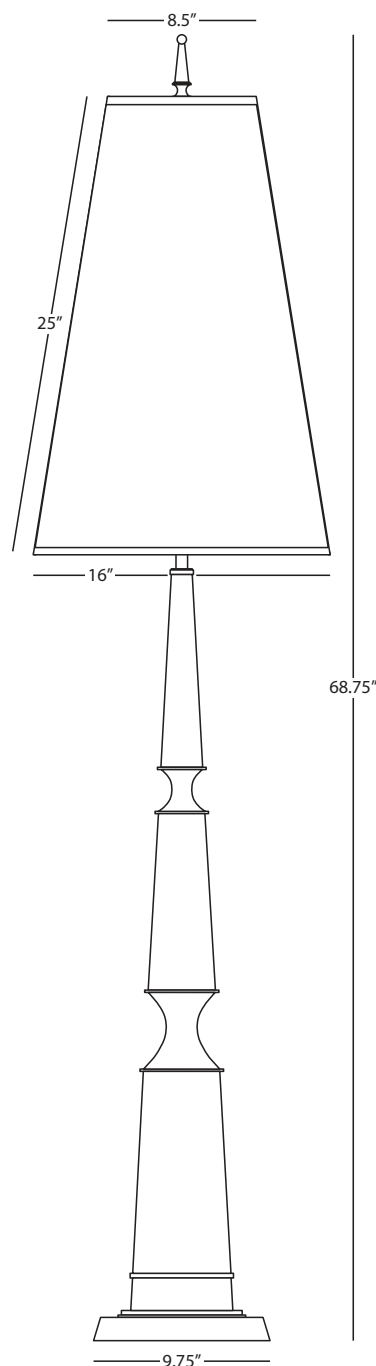

FINISH/SHADE OPTIONS:

- A902** Ash Lacquer/Modern Brass
Ash Painted Parchment w/ Matte Gold Lining
- B902** Black Lacquer/Modern Brass
Black Painted Parchment w/ Matte Gold Lining
- B902X** Black Lacquer/Modern Brass
Fondine Fabric
- C902** Navy Lacquer/Modern Brass
Navy Painted Parchment w/ Matte Gold Lining
- C902X** Navy Lacquer/Modern Brass
Fondine Fabric
- G902** Emerald Lacquer/Modern Brass
Emerald Painted Parchment w/ Matte Gold Lining
- G902X** Emerald Lacquer/Modern Brass
Fondine Fabric
- W902** Lily Lacquer/Modern Brass
Lily Painted Parchment w/ Matte Gold Lining
- W902X** Lily Lacquer/Modern Brass
Fondine Fabric



866



920



865

Jonathan Adler Vienna

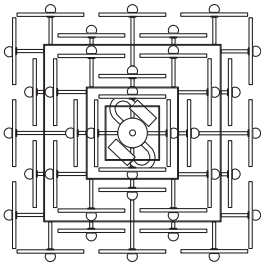

JONATHAN ADLER VIENNA

866

Small Chandelier

4 - 60W Max.
 Bulb Type: B, Candelabra
 Direct Wire
 Modern Brass Finish
 Individually Hand Blown Pulegoso Glass
 Susp. Hardware: 3 pcs. 5/8" x 12" & 1 pc.
 5/8" x 6" Extensions

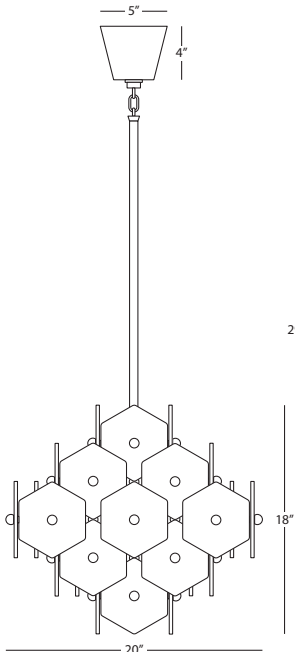

29" - 65" Adj.

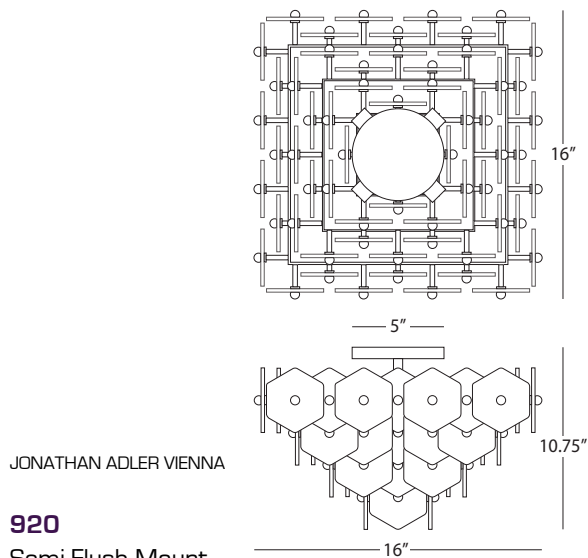
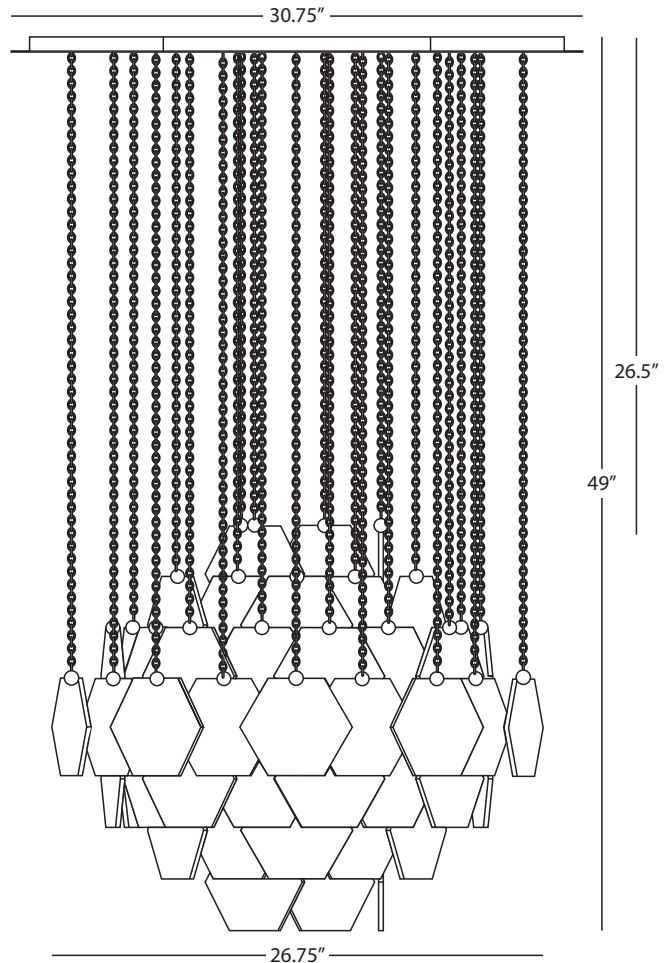

JONATHAN ADLER VIENNA

920

Semi-Flush Mount

4 - 60W Max.
 Bulb Type: B, Candelabra
 Direct Wire
 Modern Brass Finish
 Individually Hand Blown Pulegoso Glass

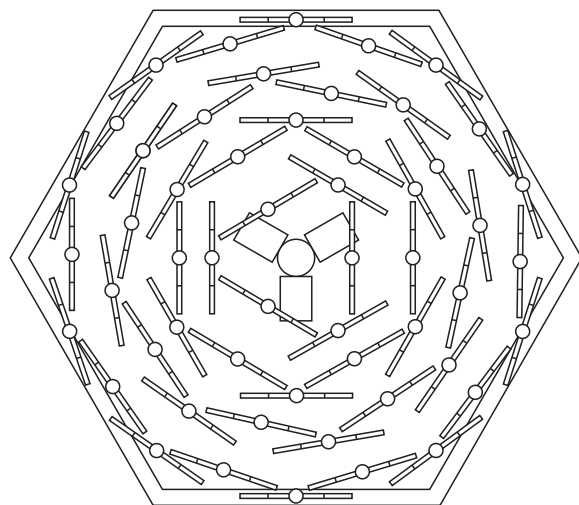

JONATHAN ADLER VIENNA

865

Large Chandelier

3 - 100W Max.
 Bulb Type: A
 Direct Wire
 Modern Brass Finish
 Individually Hand Blown Pulegoso Glass
 Susp. Hardware: 2 pcs. 5/8" x 12" &
 1 pc. 5/8" x 6" Extensions

Note: Drop Cannot be Increased Unless an Extension Kit is Purchased (Style # 865K, S865K)



888



899

Jonathan Adler Vienna

JONATHAN ADLER VIENNA

888 Small Globe Pendant

12 - 60W Max.
Bulb Type: G, Candelabra
Direct Wire
Modern Brass Finish
Individually Hand Blown White Pulegoso Glass
Susp. Hardware: 1 pc. 5/8" x 6" &
3 pcs. 5/8" x 12" Extensions

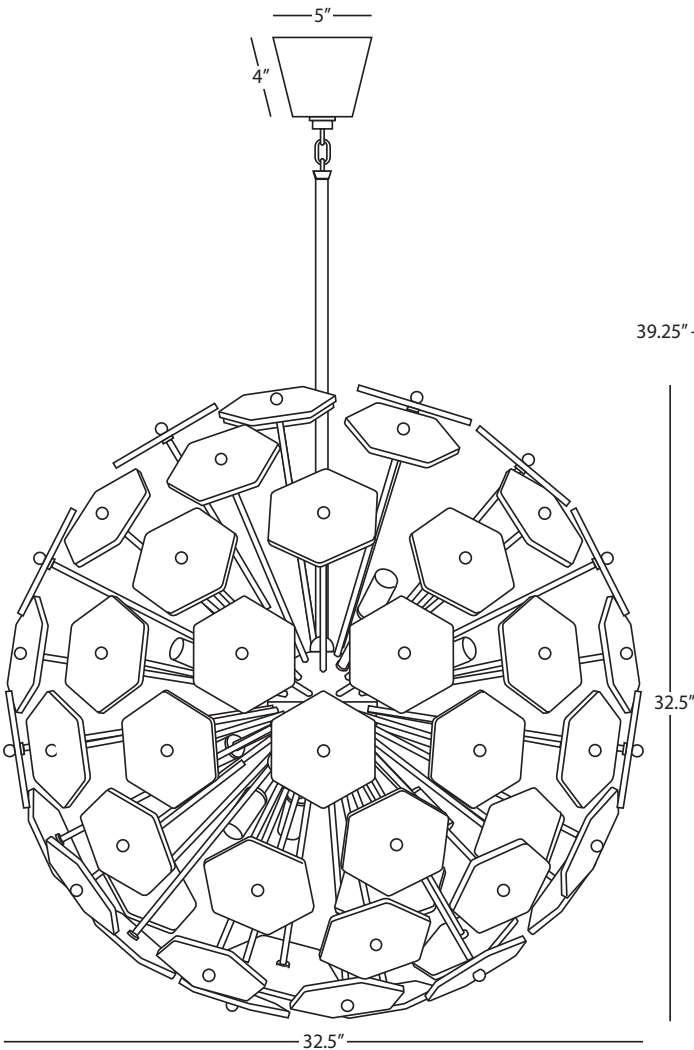
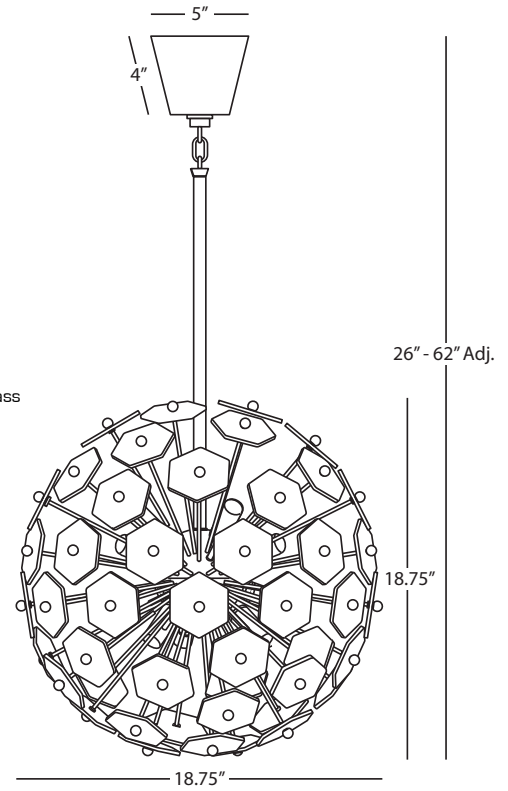

JONATHAN ADLER VIENNA

899 Large Globe Pendant

12 - 60W Max.
Bulb Type: G, Candelabra
Direct Wire
Modern Brass Finish
Individually Hand Blown White Pulegoso Glass
Susp. Hardware: 1 pc. 5/8" x 6" &
3 pcs. 5/8" x 12" Extensions

Jonathan Adler Vienna



911



912



S910

Jonathan Adler Vienna

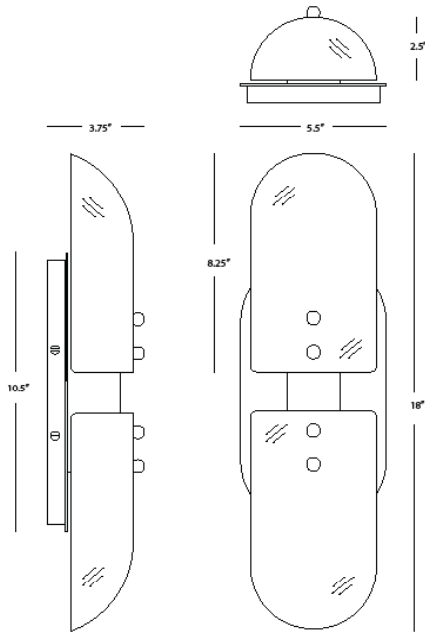

JONATHAN ADLER VIENNA

911 Wall Sconce

2 - 60W Max.
 Bulb Type: B, Medium Base
 Switch: On-Off Line Switch
 24" Cord Cover/Direct Wire
 Modern Brass Finish
 Hand Blown White Pulegoso Glass Shade
 UL Rated Damp Locations

FINISH OPTIONS:
S911 Polished Nickel

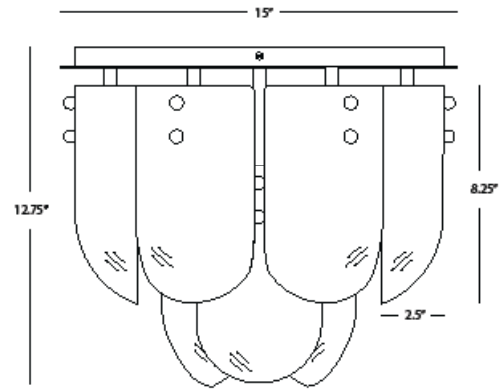

JONATHAN ADLER VIENNA

912 Wall Sconce

7 - 40W Max.
 Bulb Type: B, Medium Base
 Direct Wire Only
 Modern Brass Finish
 Hand Blown White Pulegoso Glass Shades
 UL Rated Damp Locations

FINISH OPTIONS:
S912 Polished Nickel

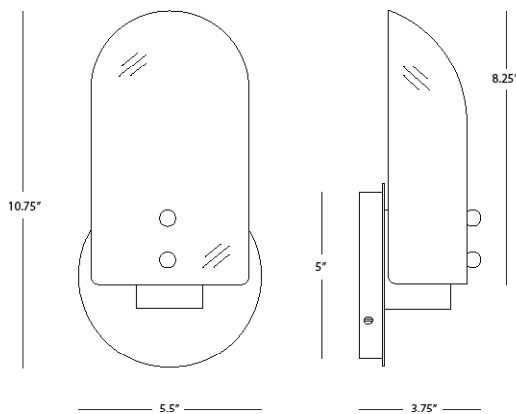
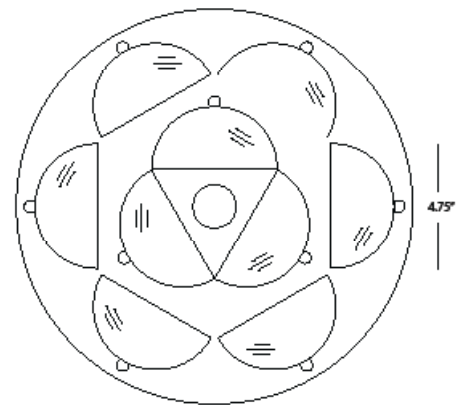

JONATHAN ADLER VIENNA

S910 Wall Sconce

1 - 60W Max.
 Bulb Type: B, Medium Base
 Switch: On-Off Line Switch
 24" Cord Cover/Direct Wire
 Polished Nickel Finish
 Hand Blown White Pulegoso Glass Shade
 UL Rated Damp Locations

FINISH OPTIONS:
910 Modern Brass

Mavisten Edition



Mavisten Edition was founded in 2018 by Michael Almodova after 20 years of industry experience from former positions at Restoration Hardware, Pottery Barn, and Arhaus. Michael grew up with inventive influences from his dad, who was an airplane mechanic in the US Air Force, and a grandfather who worked on the Union Pacific Railroad.

His passion for lighting began at the age of 8 when his dad taught him how to wire and solder. His interest led him to an education in product design and engineering from Stanford University, which paved the way to his design career. He now leads the Mavisten Edition design team, who all champion his mission for celebrating the magic of light with innovative design.



MAVISTEN EDITION

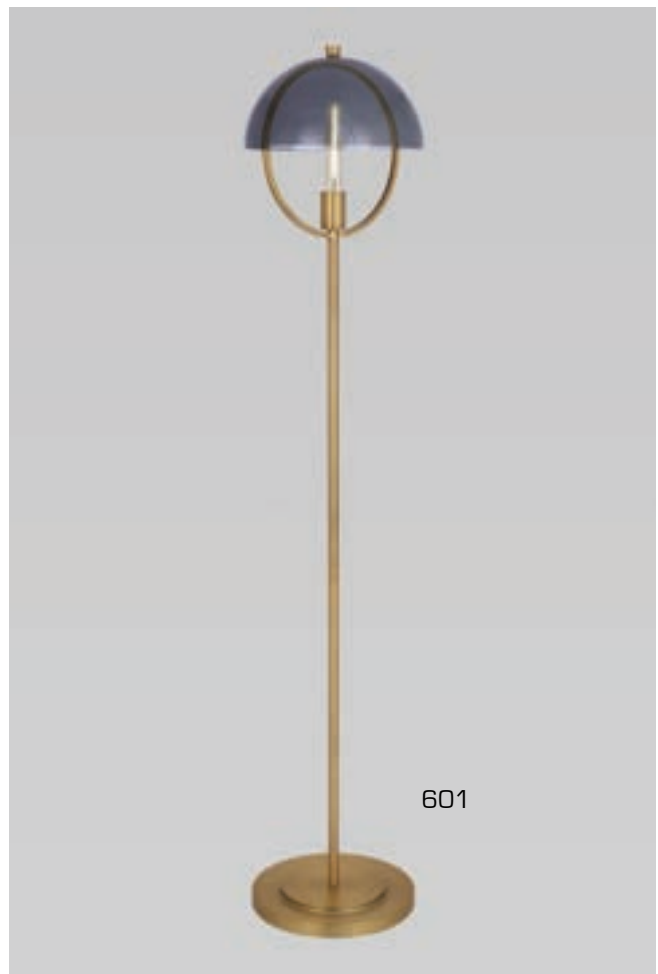

Mavisten Edition Copernica

* All styles ship with Mavisten Edition Emberline LED Bulbs*



600



602



603



601

Copernica has a distinguished design that was inspired by galaxies and their never-ending revolutions. This collection provides delicate warmth and a beautiful sense of balance.

Mavisten Edition Copernica

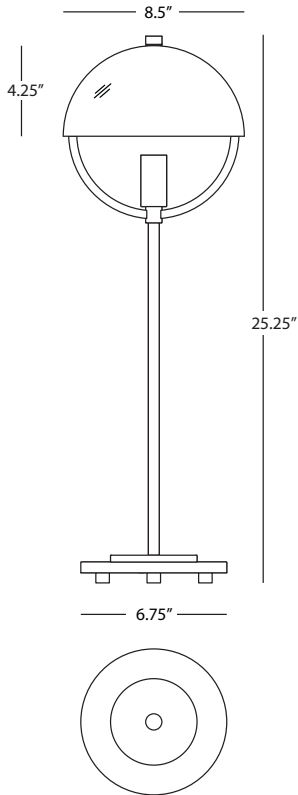

MAVISTEN EDITION COPERNICA

600 Table Lamp

1 - 60W Max.
 Bulb Type: B, Candelabra Base
 Switch: Full Range Dimmer Line Switch
 Burnished Brass Finish
 Smoked Glass Shade
 Bulb Included

MAVISTEN EDITION COPERNICA

603 Chandelier

3 - 100W Max.
 Bulb Type: A
 Direct Wire Only
 Burnished Brass Finish
 Smoked Glass Shade
 Susp. Hardware: 3 ft. Chain
 Bulb Included

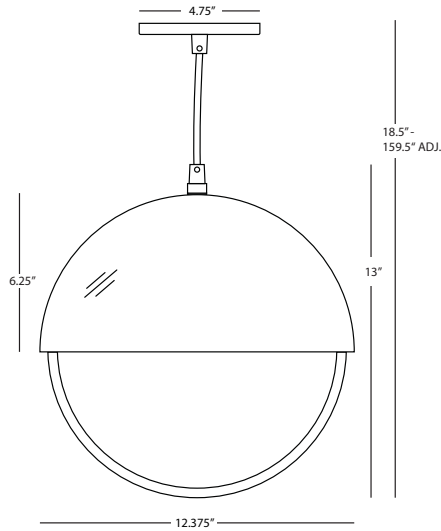

MAVISTEN EDITION COPERNICA

602 Pendant

1 - 100W Max.
 Bulb Type: A
 Direct Wire Only
 Burnished Brass Finish
 Smoked Glass Shade
 Susp. Hardware: 12ft. Black Fabric Wrapped Cord
 Bulb Included

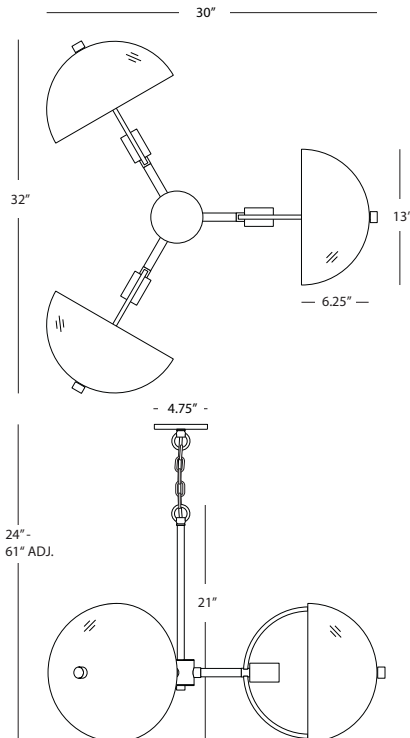

MAVISTEN EDITION COPERNICA

601 Floor Lamp

1 - 150W Max.
 Bulb Type: A
 Switch: On-Off Line Switch
 Burnished Brass Finish
 Smoked Glass Shade
 Bulb Included

Mavisten Edition Far

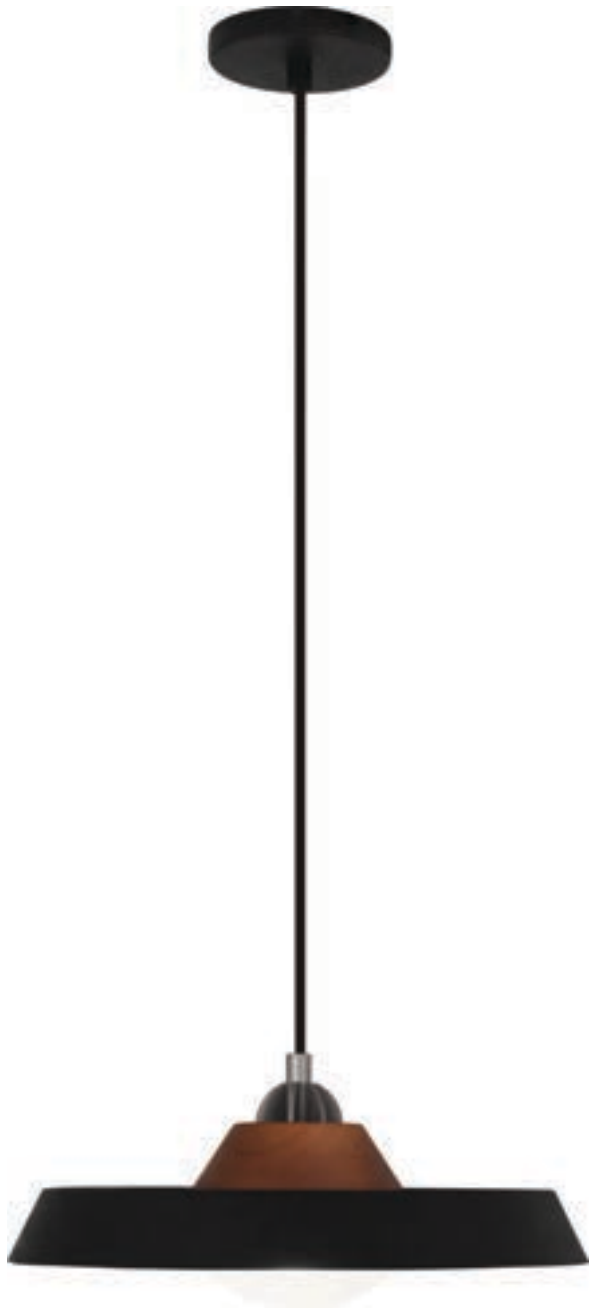

B515



W515

The Far collection combines metal, wood, and a twist on historic lighting design to create a modest yet chic impression.

Mavisten Edition Far

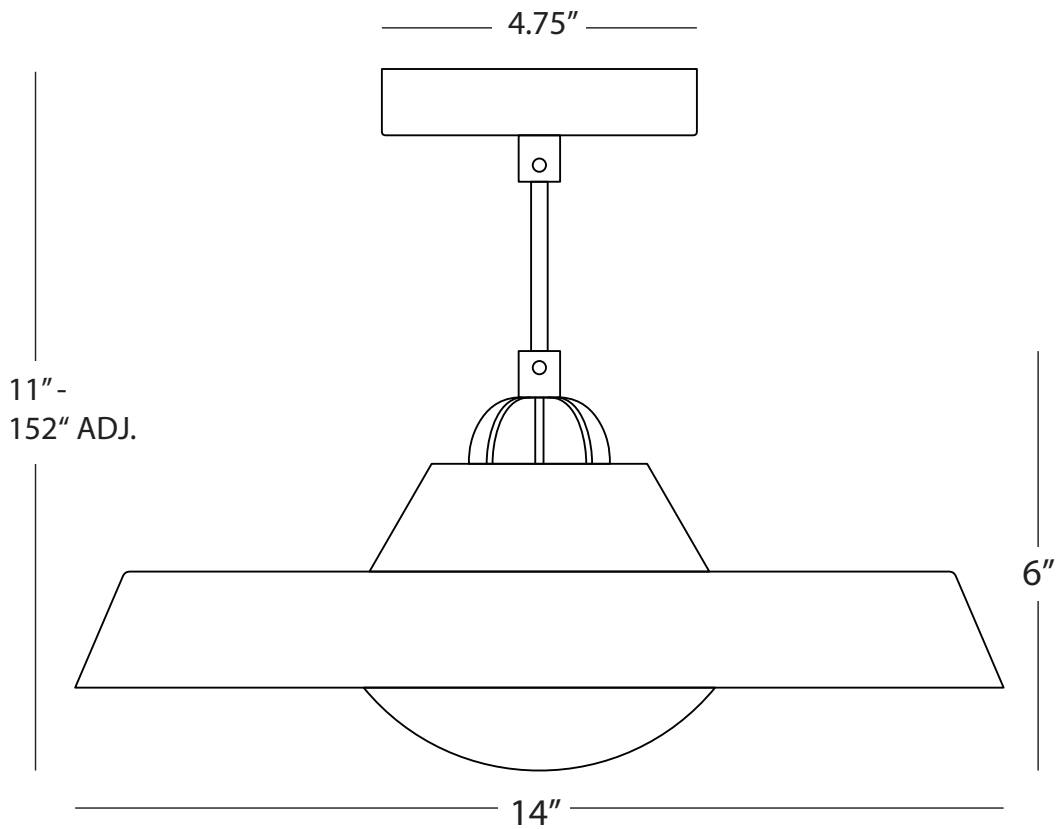

MAVISTEN EDITION FAR

B515

Pendant

1 - 5W Max.
Bulb Type: 120V G9 Bi-Pin LED
Direct Wire Only
Black Textured Powdercoat Finish
Metal Shade
Ash Wood and Gunmetal Accents
Susp. Hardware: 12ft. Black Fabric Wrapped
Cord

FINISH OPTIONS:

W515 White Textured Powdercoat with
Black and White Chevron Cord

WILLIAMSBURG



Photograph courtesy of The Colonial Williamsburg Foundation

Trend meets tradition in the WILLIAMSBURG collection. Inspired by 18th-century patterns in rare books, architectural details in the “Revolutionary City,” and decorative details and colors in the vast design archive of the Colonial Williamsburg Foundation, Robert Abbey’s talented design team has developed lamps and fixtures with timeless style and contemporary appeal. They’ve channeled global chic from England’s 18th-century trade goods and paired Asian elegance with urns that represent the classical foundations of British and American architectural heritage.

WILLIAMSBURG is the brand of The Colonial Williamsburg Foundation, the large not-for-profit organization that keeps history alive by maintaining the country’s oldest and largest outdoor history museum. Here, visionaries like Thomas Jefferson and Patrick Henry debated the promise—and perils—of a revolution that would change the course of history and lead to the founding of the United States of America. Sales of WILLIAMSBURG products support the mission of historical education, preservation, and the nurture of active citizen engagement.

Established in 1936, WILLIAMSBURG invented licensing of museum-based home furnishings. Today they collaborate with over 40 licensees, including Robert Abbey, Inc., Benjamin Moore, and Global Views, to offer classic American style for the way we live today. To learn more about the licensing program, visit www.WILLIAMSBURGbrand.com. To learn more about The Colonial Williamsburg Foundation, visit www.colonialwilliamsburg.com.

© 2019 The Colonial Williamsburg Foundation
WILLIAMSBURG is a trademark of The Colonial Williamsburg Foundation.



WB331

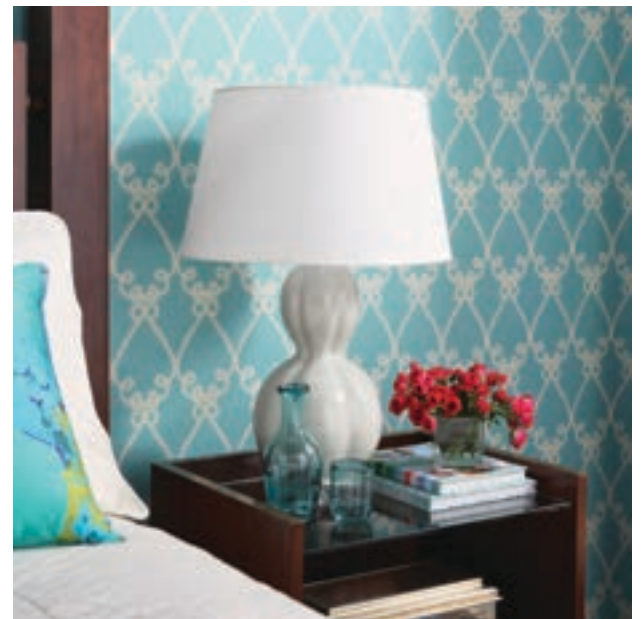

BW997

WILLIAMSBURG



S439



260



358



WB336



WB339



BN333



BN347



WB348



WB330



BN334



BN328

WILLIAMSBURG Custis

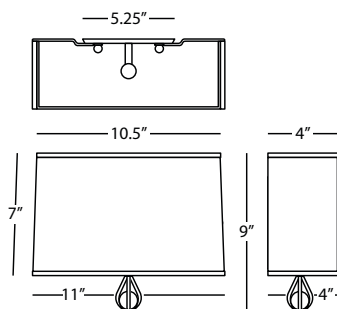

WILLIAMSBURG CUSTIS

BN347

Wall Sconce

1 - 40W Max.
 Bulb Type: B, Candelabra
 Direct Wire Only
 Modern Brass Finish
 Lead Crystal Finial
 William Of Orange Fabric Shade
 w/ Revolutionary Storm Lining
 ADA Compliant

FINISH/SHADE OPTIONS:

- BN348** Modern Brass
 Richmond Red/Blacksmith Black Lining
- BN349** Modern Brass
 Blacksmith Black/Richmond Red Lining

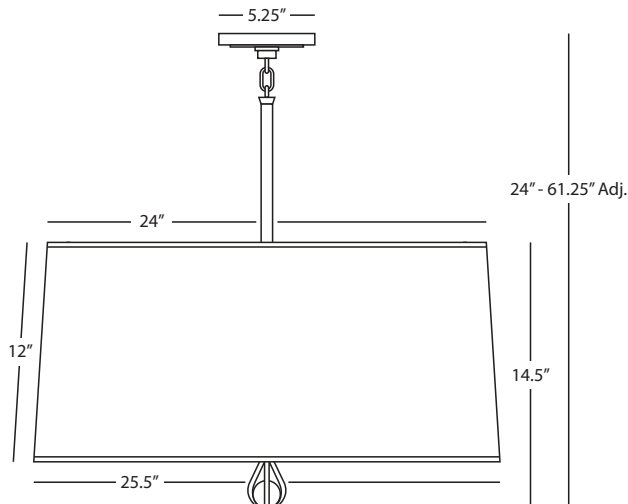

WILLIAMSBURG CUSTIS

BN328

Pendant

3 - 100W Max.
 Bulb Type: A
 Direct Wire
 Modern Brass Finish
 Lead Crystal Finial
 Ink Blue Fabric Shade w/
 Carter Gray Lining
 13.25" Dia. Polished Nickel Metal Diffuser
 Susp. Hardware: 3 pcs. 5/8" x 12" &
 1 pc. 5/8" x 6" Extensions

FINISH/SHADE OPTIONS:

- WB328** Polished Nickel
 Ink Blue/Carter Gray Lining
- BN329** Modern Brass
 Carter Gray/Ink Blue Lining
- WB329** Polished Nickel
 Carter Gray/Ink Blue Lining
- BN330** Modern Brass
 Mayo Teal/Carter Gray Lining
- WB330** Polished Nickel
 Mayo Teal/Carter Gray Lining
- BN331** Modern Brass
 Carter Gray/Mayo Teal Lining
- WB331** Polished Nickel
 Carter Gray/Mayo Teal Lining
- BN332** Modern Brass
 Parrot Green/Revolutionary Storm Lining
- WB332** Polished Nickel
 Parrot Green/Revolutionary Storm Lining
- BN333** Modern Brass
 Revolutionary Storm/Parrot Green Lining
- WB333** Polished Nickel
 Revolutionary Storm/Parrot Green Lining
- BN334** Modern Brass
 Greenhow Grape/Ludwell Lilac Lining
- WB334** Polished Nickel
 Greenhow Grape/Ludwell Lilac Lining
- BN335** Modern Brass
 Ludwell Lilac/Greenhow Grape Lining
- WB335** Polished Nickel
 Ludwell Lilac/Greenhow Grape Lining
- BN336** Modern Brass
 Revolutionary Storm/William of Orange Lining
- WB336** Polished Nickel
 Revolutionary Storm/William of Orange Lining
- BN337** Modern Brass
 William of Orange/Revolutionary Storm Lining
- WB337** Polished Nickel
 William of Orange/Revolutionary Storm Lining
- BN338** Modern Brass
 Richmond Red/Blacksmith Black Lining
- WB338** Polished Nickel
 Richmond Red/Blacksmith Black Lining
- BN339** Modern Brass
 Blacksmith Black/Richmond Red Lining
- WB339** Polished Nickel
 Blacksmith Black/Richmond Red Lining

WILLIAMSBURG Finnie



S359



362

WILLIAMSBURG Finnie

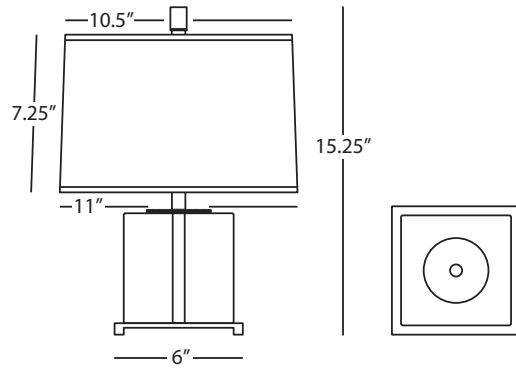

WILLIAMSBURG FINNIE

362 Accent Lamp

1 - 60W Max.
Bulb Type: G16.5, Candelabra
Switch: Hi-Lo Line Switch
Modern Brass Finish
Clear Lead Crystal
Cloud Cream Shade w/
Self-Fabric Top Diffuser

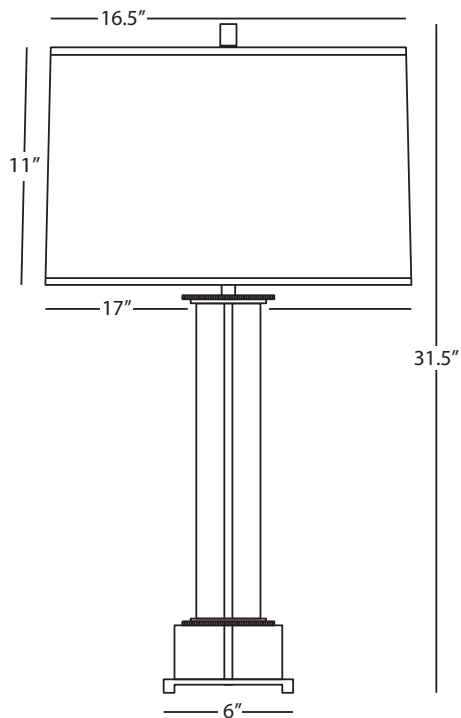

WILLIAMSBURG FINNIE

S359 Table Lamp

1 - 150W Max.
Bulb Type: A
Switch: Hi-Lo Dimming
Polished Nickel Finish
Clear Lead Crystal
White Silk Shade

FINISH/SHADE OPTION:
359 Modern Brass/
Cloud Cream Silk

WILLIAMSBURG Lightfoot



1031



1035



S1033



S1030



Z1032



Z1034

WILLIAMSBURG Lightfoot

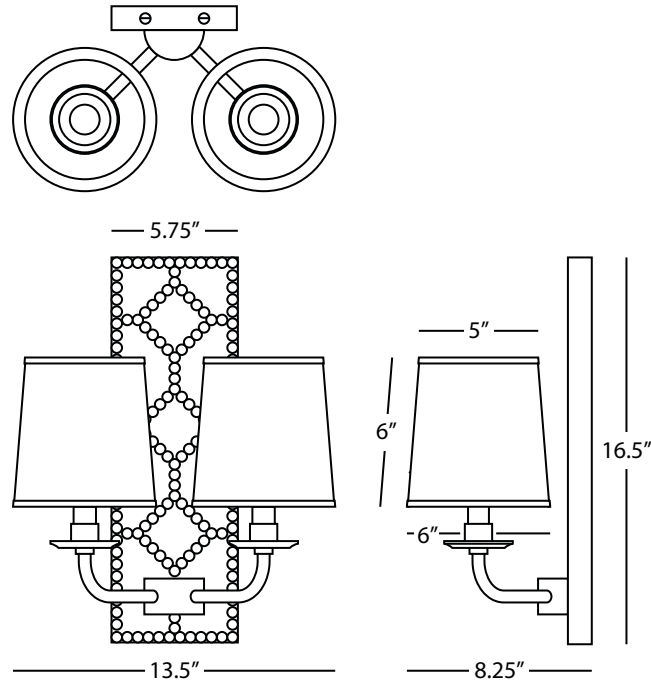

WILLIAMSBURG LIGHTFOOT

1031

Double Sconce

2 - 60W Max.
Bulb Type: B, Candelabra
Direct Wire Only
Backplate Upholstered in Dragons Blood
Leather w/ Nailhead Detail
Aged Brass Accents
Fondine Fabric Shades

FINISH OPTIONS:

S1031 Polished Nickel Accents
Z1031 Deep Patina Bronze Accents

WILLIAMSBURG LIGHTFOOT

1035

Double Sconce

2 - 60W Max.
Bulb Type: B, Candelabra
Direct Wire Only
Backplate Upholstered in Blacksmith Black
Leather w/ Nailhead Detail
Aged Brass Accents
Fondine Fabric Shades

FINISH OPTIONS:

S1035 Polished Nickel Accents
Z1035 Deep Patina Bronze Accents

WILLIAMSBURG LIGHTFOOT

S1033

Double Sconce

2 - 60W Max.
Bulb Type: B, Candelabra
Direct Wire Only
Backplate Upholstered in Worcester Peacock
Leather w/ Nailhead Detail
Polished Nickel Accents
Fondine Fabric Shades

FINISH OPTIONS:

1033 Aged Brass Accents
Z1033 Deep Patina Bronze Accents

WILLIAMSBURG LIGHTFOOT

S1030

Double Sconce

2 - 60W Max.
Bulb Type: B, Candelabra
Direct Wire Only
Backplate Upholstered in English Ochre
Leather w/ Nailhead Detail
Polished Nickel Accents
Fondine Fabric Shades

FINISH OPTIONS:

1030 Aged Brass Accents
Z1030 Deep Patina Bronze Accents

WILLIAMSBURG LIGHTFOOT

Z1032

Double Sconce

2 - 60W Max.
Bulb Type: B, Candelabra
Direct Wire Only
Backplate Upholstered in Bruton White
Leather w/ Nailhead Detail
Deep Patina Bronze Accents
Fondine Fabric Shades

FINISH OPTIONS:

1032 Aged Brass Accents
S1032 Polished Nickel Accents

WILLIAMSBURG LIGHTFOOT

Z1034

Double Sconce

2 - 60W Max.
Bulb Type: B, Candelabra
Direct Wire Only
Backplate Upholstered in Carter Gray
Leather w/ Nailhead Detail
Deep Patina Bronze Accents
Fondine Fabric Shades

FINISH OPTIONS:

1034 Aged Brass Accents
S1034 Polished Nickel Accents



260

Z260B

S260B

WILLIAMSBURG Orlando

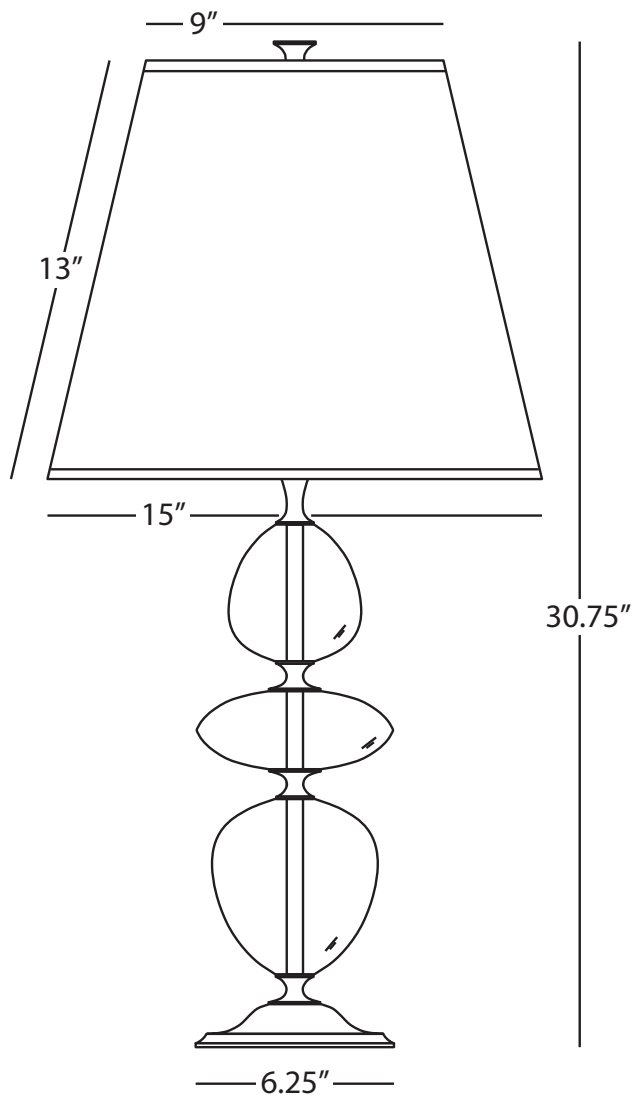

WILLIAMSBURG ORLANDO

260

Table Lamp

1 - 150W Max.
Bulb Type: A
Switch: Full Range Dimmer
Clear Crystal w/
Modern Brass Accents
Oyster Linen Shade

FINISH/SHADE OPTIONS:

- 260B** Modern Brass/Black Parchment w/ Matte Gold Lining
- S260** Polished Nickel/Oyster Linen
- S260B** Polished Nickel/Black Parchment w/ Matte Silver Lining
- Z260** Deep Patina Bronze/Oyster Linen
- Z260B** Deep Patina Bronze/Black Parchment w/ Matte Silver Lining

WILLIAMSBURG Randolph



LB997



DB997



CG997



CP997



BW997



PG997



MT997

WILLIAMSBURG Randolph

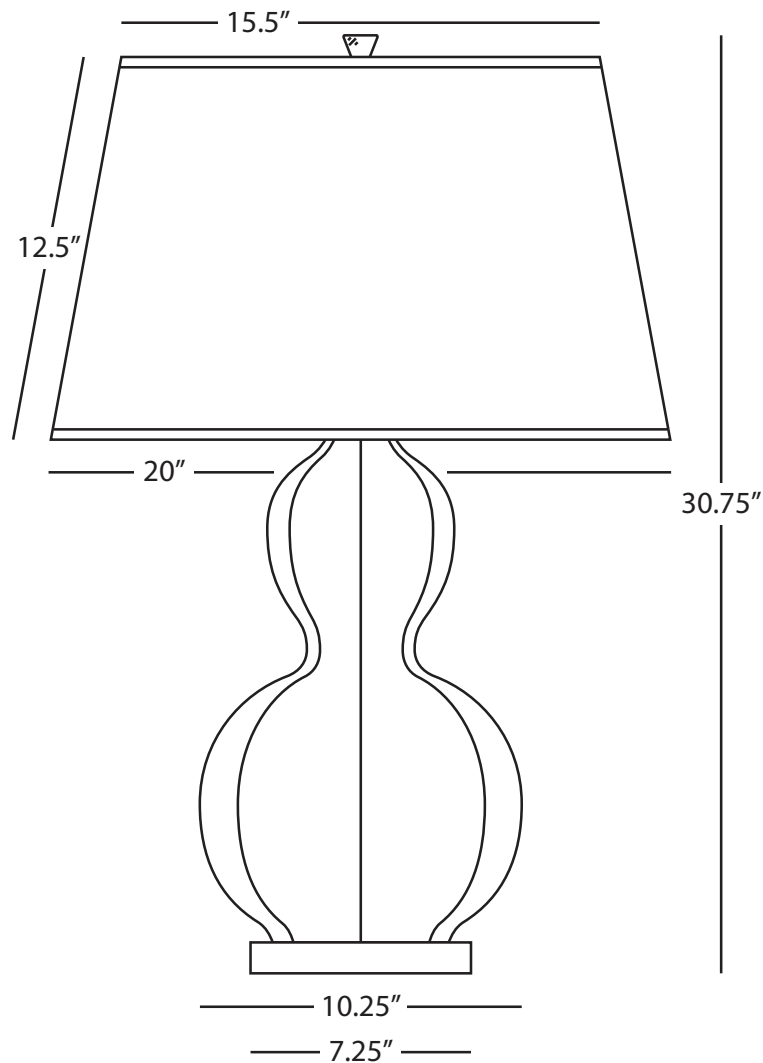

WILLIAMSBURG RANDOLPH

BW997

Table Lamp

1 - 150W Max.

Bulb Type: A

Switch: Hi-Lo Dimming

Bruton White (Soft Gray) Glazed Ceramic
w/ Polished Nickel Metal Parts

Lucite Base

Pearl Dupioni Fabric Shade

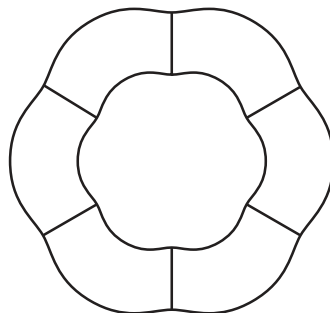

COLOR OPTIONS:

- CG997** Carter Gray (Gray-Taupe)
- CP997** Carter Plum (Deep Mauve)
- DB997** Dragons Blood (Rusty Orange-Red)
- LB997** Lampblack (Dark Gray)
- MT997** Mayo Teal (Blue-Green)
- PG997** Parrot Green (Muted Chartreuse)

WILLIAMSBURG Spotswood



S150



150

WILLIAMSBURG Spotswood

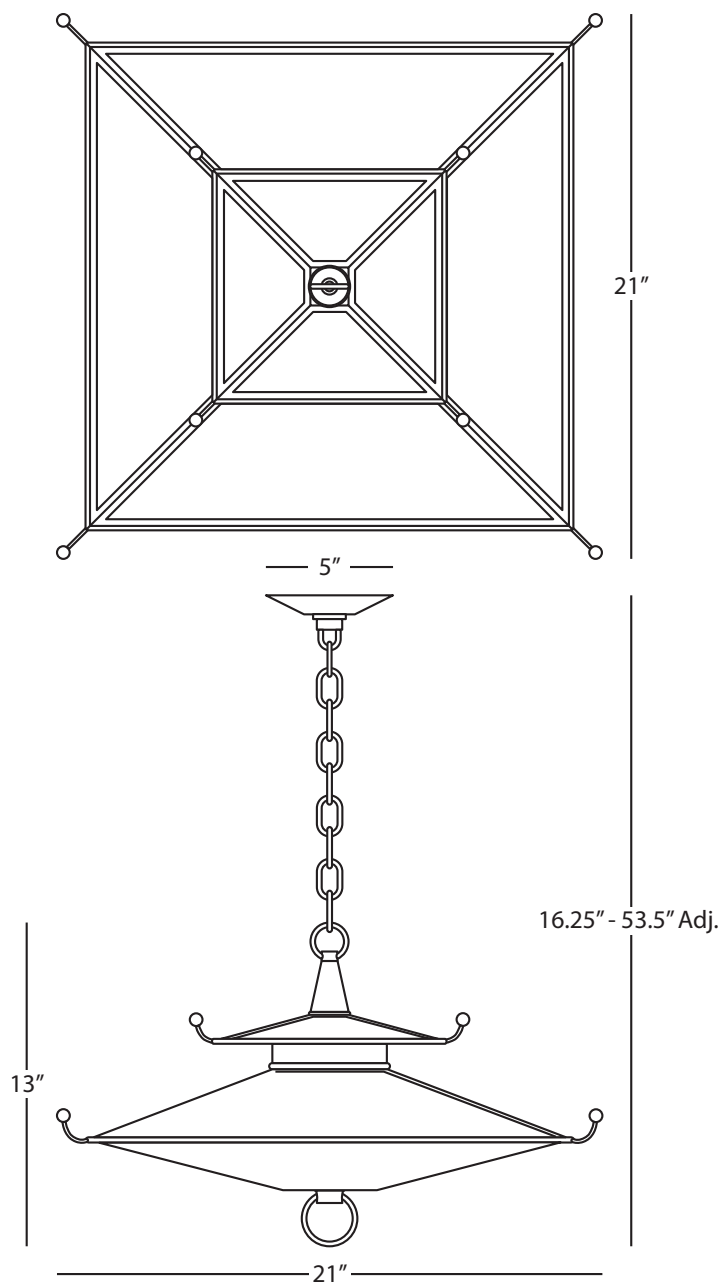

WILLIAMSBURG SPOTSWOOD

150

Pendant

1 - 23W Max. LED Unit
(2300 Lumen Output)
Bulb Type: LED, Included (Non-replaceable)
LED Color Temp: 3000K, CRI: 80
Direct Wire
Deep Patina Bronze Finish w/
Modern Brass Accents
Frosted Acrylic Diffuser
Susp. Hardware: 3 Ft. Chain

FINISH OPTION:

S150 Antique Silver Accents



439



S438

WILLIAMSBURG Tazewell

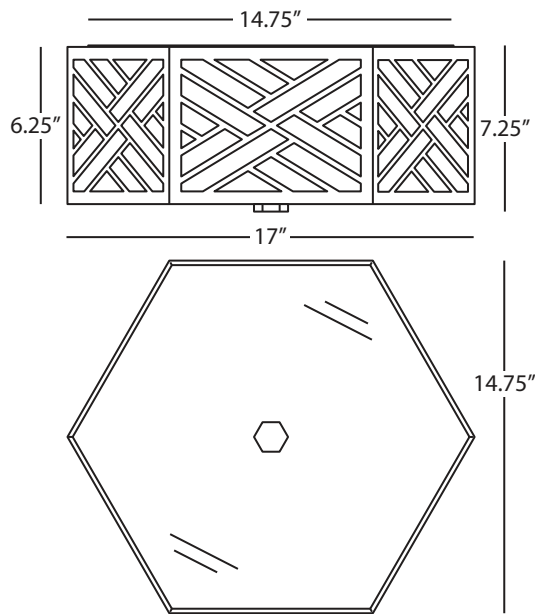

WILLIAMSBURG TAZEWell

S438

Flush Mount

1 - 23W Max. LED Unit
(2540 Lumen Output)
Bulb Type: LED, Included (Non-replaceable)
LED Color Temp: 3000K, CRI: 80
Direct Wire
Polished Nickel Finish
Printed White Glass Shade Panels

FINISH OPTION:

438 Modern Brass

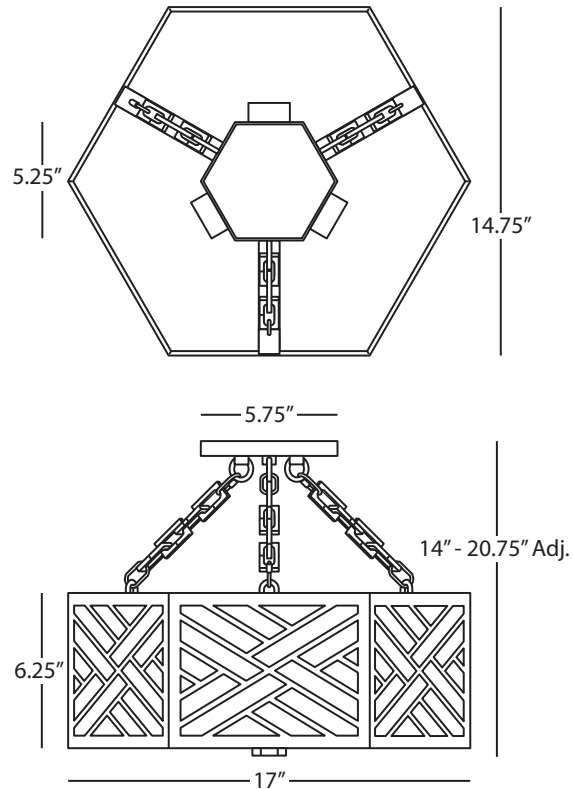

WILLIAMSBURG TAZEWell

439

Semi-Flush Mount

1 - 23W Max. LED Unit
(2540 Lumen Output)
Bulb Type: LED, Included (Non-replaceable)
LED Color Temp: 3000K, CRI: 80
Direct Wire
Modern Brass Finish
Printed White Glass Shade Panels
Susp. Hardware: 9" Chain [x3]

FINISH OPTION:

S439 Polished Nickel



Z307



S306

WILLIAMSBURG Tucker

WILLIAMSBURG TUCKER

306

Small Flush Mount

2 - 40W Max.
Bulb Type: B, Medium
Direct Wire
Antique Brass Finish
Frosted White Cased Glass Shade

FINISH OPTIONS:

S306 Polished Nickel
Z306 Deep Patina Bronze

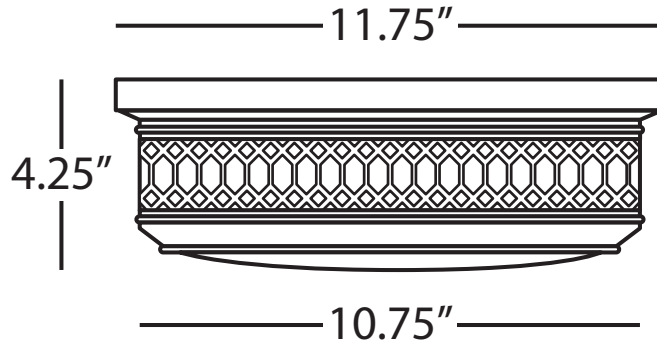

WILLIAMSBURG TUCKER

Z307

Large Flush Mount

3 - 40W Max.
Bulb Type: B, Medium
Direct Wire
Deep Patina Bronze Finish
Frosted White Cased Glass Shade

FINISH OPTIONS:

307 Antique Brass
S307 Polished Nickel

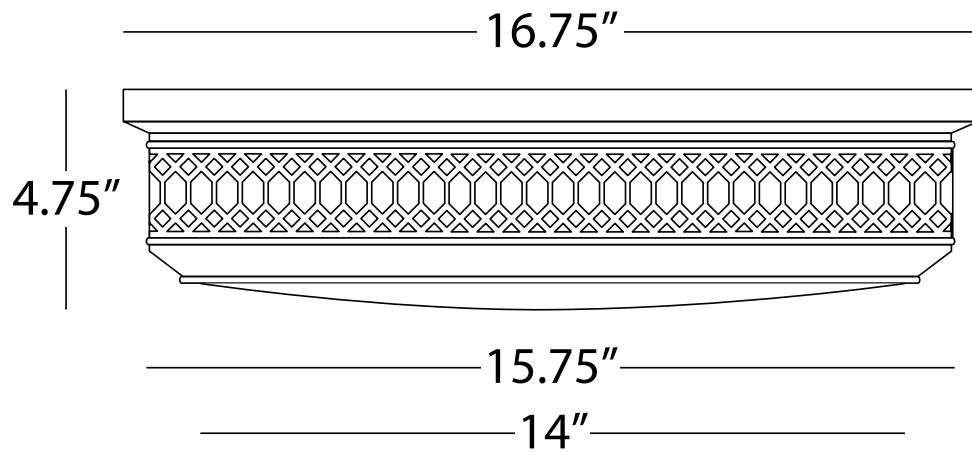

WILLIAMSBURG Tyrie



411



Z411

WILLIAMSBURG Tyrie

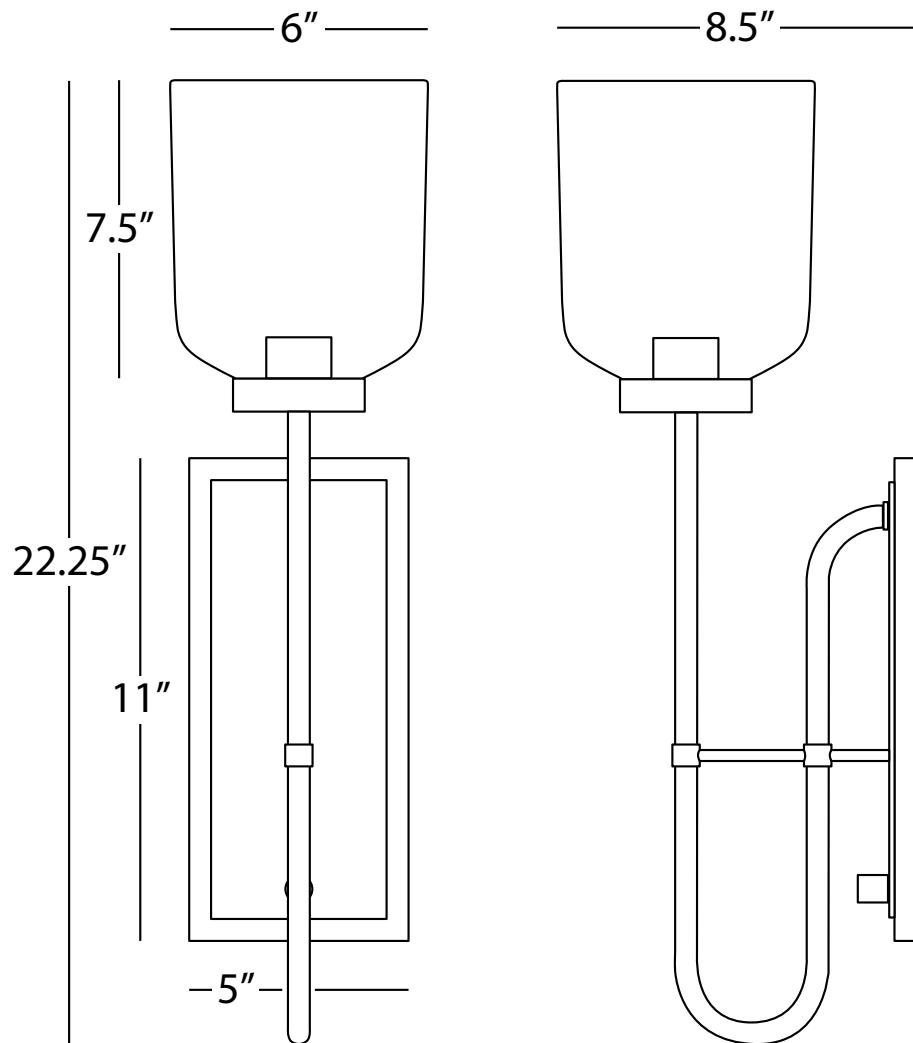

WILLIAMSBURG TYRIE

411

Wall Sconce

1 - 100W Max.
Bulb Type: A
Switch: Hi-Lo Dimming
24" Cord Cover / Direct Wire
Antique Brass Finish
Clear Glass Shade

Photographed with Historical Bulb
SOLD SEPARATELY
(HIS01 See Page 225)

FINISH OPTIONS:

D411 Dark Antique Nickel
Z411 Deep Patina Bronze



MICHAEL BERMAN

Renowned interiors and product designer Michael Berman has created a portfolio of projects that span the globe. From residential homes to luxury hotels, his signature “Trans-Modern” American style reflects the designer’s interest in history, art, architecture, and nature, forming a heady mix of completely livable – and widely celebrated – interiors, furniture, lighting, and textiles. His work strikes an uncommon balance between timeless style and of-the-moment relevance inspired by comfort, American Modernism, simplicity of form, and classic Hollywood glamour. Berman’s work resonates with design industry colleagues for its attention to detail and usable scale. Michael has crafted an epic romance that blends the luxury of casual lifestyle and eclectic cinematic swank. “My objective is to create classics with restraint and elegance that will stand the test of time.”

Berman is the founder and principal creative visionary behind his west coast based Bronze Studio and Michael Berman Limited, a multi-faceted design firm focusing on interiors, architecture, furniture, and all aspirational products for home design.



Upholstery by Wesley Hall Inc.

MICHAEL BERMAN



626



MCR21



543

Michael Berman Atlas



MDV21



MDC20



MWR22



MSB21



MMB20



MCR22

Michael Berman Atlas

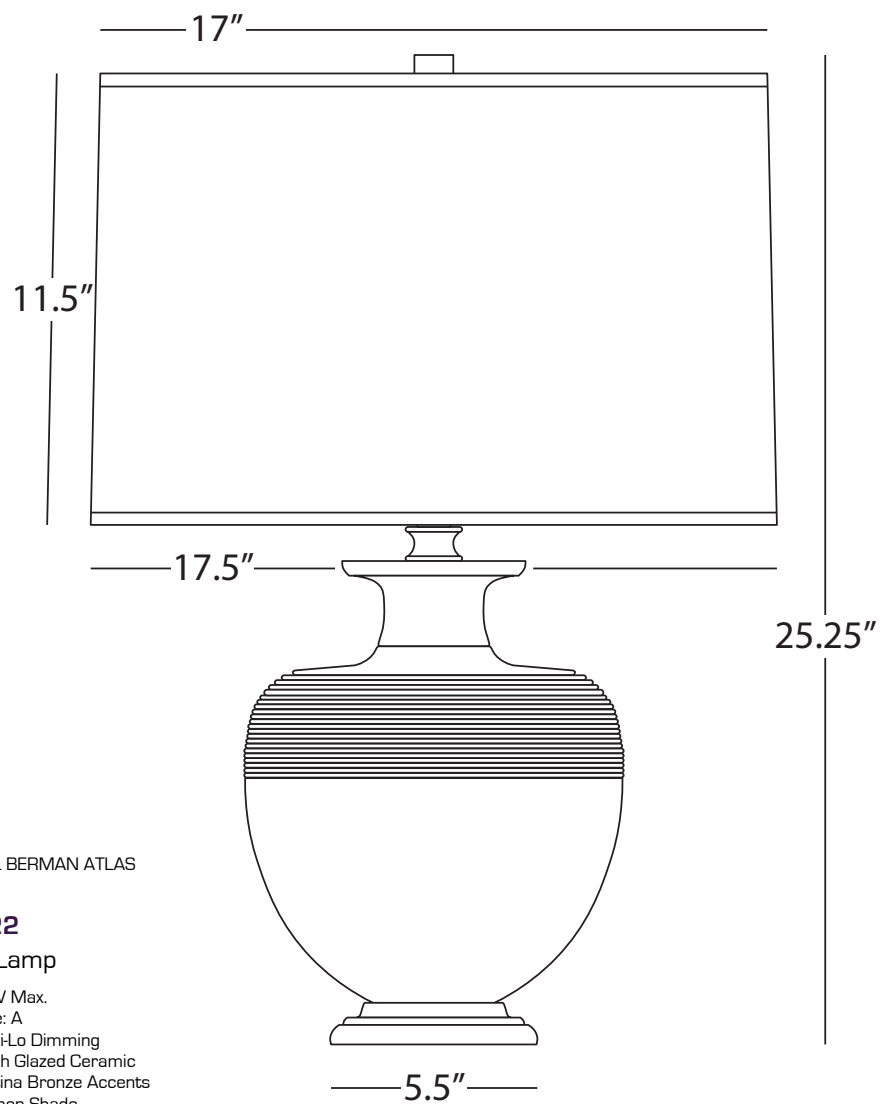

MICHAEL BERMAN ATLAS

MCR22

Table Lamp

1 - 150W Max.

Bulb Type: A

Switch: Hi-Lo Dimming

Matte Ash Glazed Ceramic

Deep Patina Bronze Accents

Oyster Linen Shade

See Page 508 for Color/Base Options

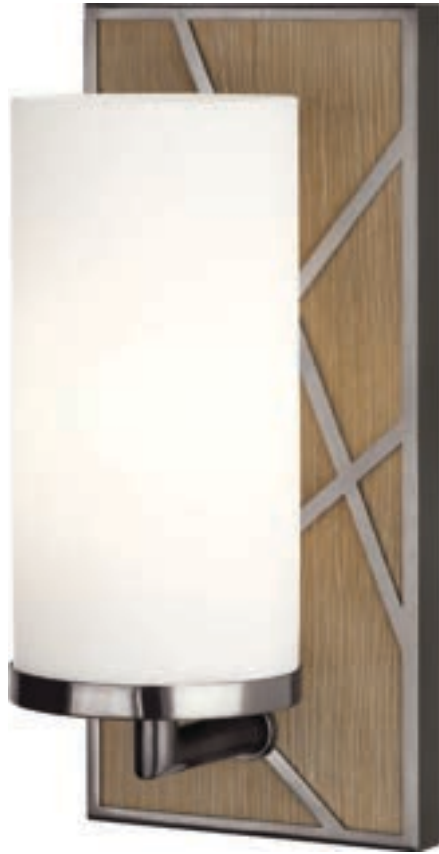

553W



533

Michael Berman Bond

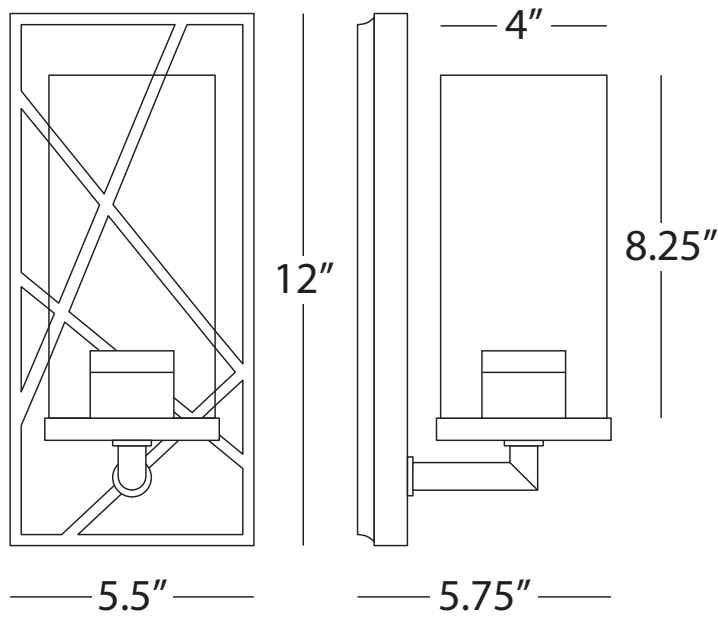

MICHAEL BERMAN BOND

533

Wall Sconce

1 - 100W Max.
Bulb Type: A
Direct Wire Only
Deep Patina Bronze Finish
Modern Brass Accents
Clear Glass Shade

FINISH/SHADE OPTIONS:

543	Smoked Walnut/Deep Patina Bronze Clear Glass
543W	Smoked Walnut/Deep Patina Bronze Frosted, Cased, White Glass
553	Driftwood Oak/Blackened Nickel Clear Glass
553W	Driftwood Oak/Blackened Nickel Frosted, Cased, White Glass



S620



622



Z621

Michael Berman Brut

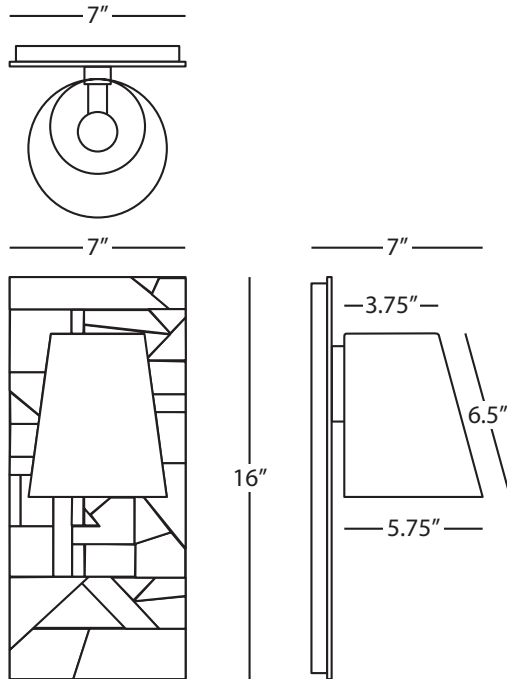

MICHAEL BERMAN BRUT

622 Outdoor Wall Sconce

1 - 60W Max.
Bulb Type: A
Direct Wire Only
Modern Brass Finish
Metal Shade
UL Rated for Wet Locations

FINISH OPTIONS:
S622 Polished Nickel

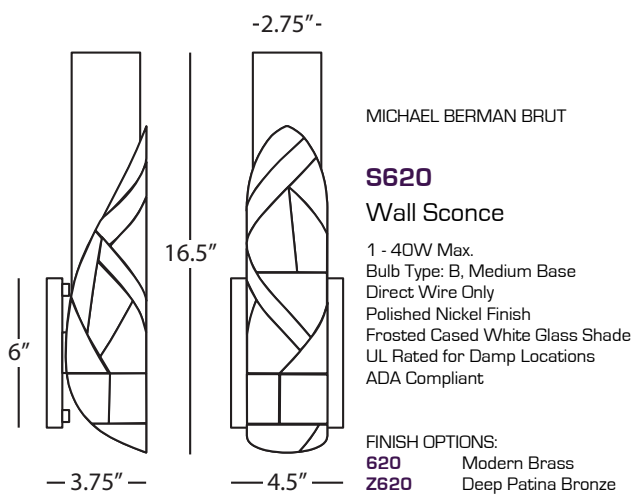

MICHAEL BERMAN BRUT

S620 Wall Sconce

1 - 40W Max.
Bulb Type: B, Medium Base
Direct Wire Only
Polished Nickel Finish
Frosted Cased White Glass Shade
UL Rated for Damp Locations
ADA Compliant

FINISH OPTIONS:
620 Modern Brass
Z620 Deep Patina Bronze

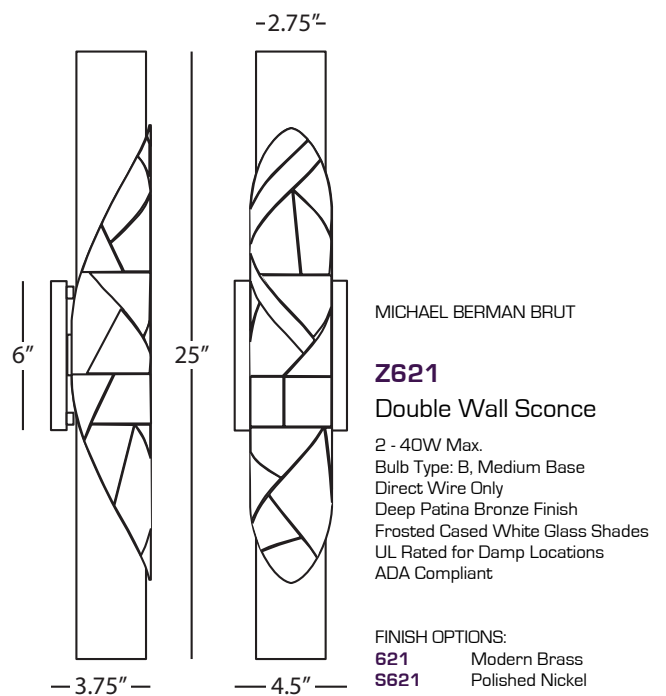

MICHAEL BERMAN BRUT

Z621 Double Wall Sconce

2 - 40W Max.
Bulb Type: B, Medium Base
Direct Wire Only
Deep Patina Bronze Finish
Frosted Cased White Glass Shades
UL Rated for Damp Locations
ADA Compliant

FINISH OPTIONS:
621 Modern Brass
S621 Polished Nickel

Michael Berman Brut



628



S627



Z627

Michael Berman Brut

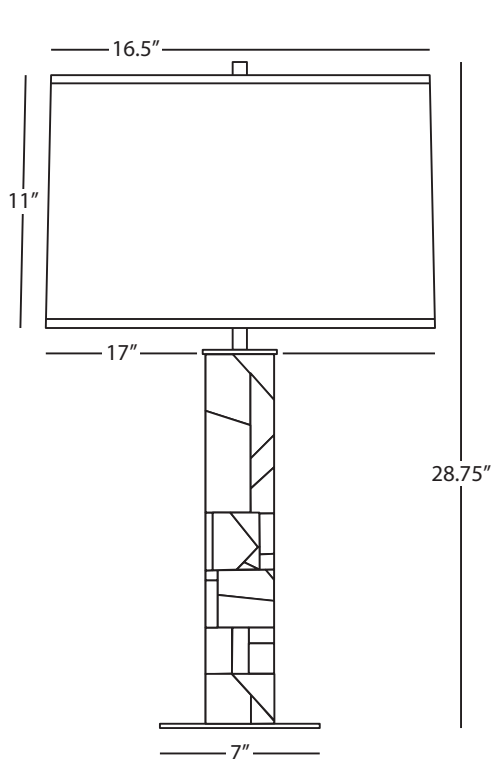

MICHAEL BERMAN BRUT

S627

Table Lamp

1 - 150W Max.
Bulb Type: A
Switch: Full Range Dimmer
Polished Nickel Finish
Ascot White Fabric Shade

FINISH OPTIONS:

627 Modern Brass
Z627 Deep Patina Bronze

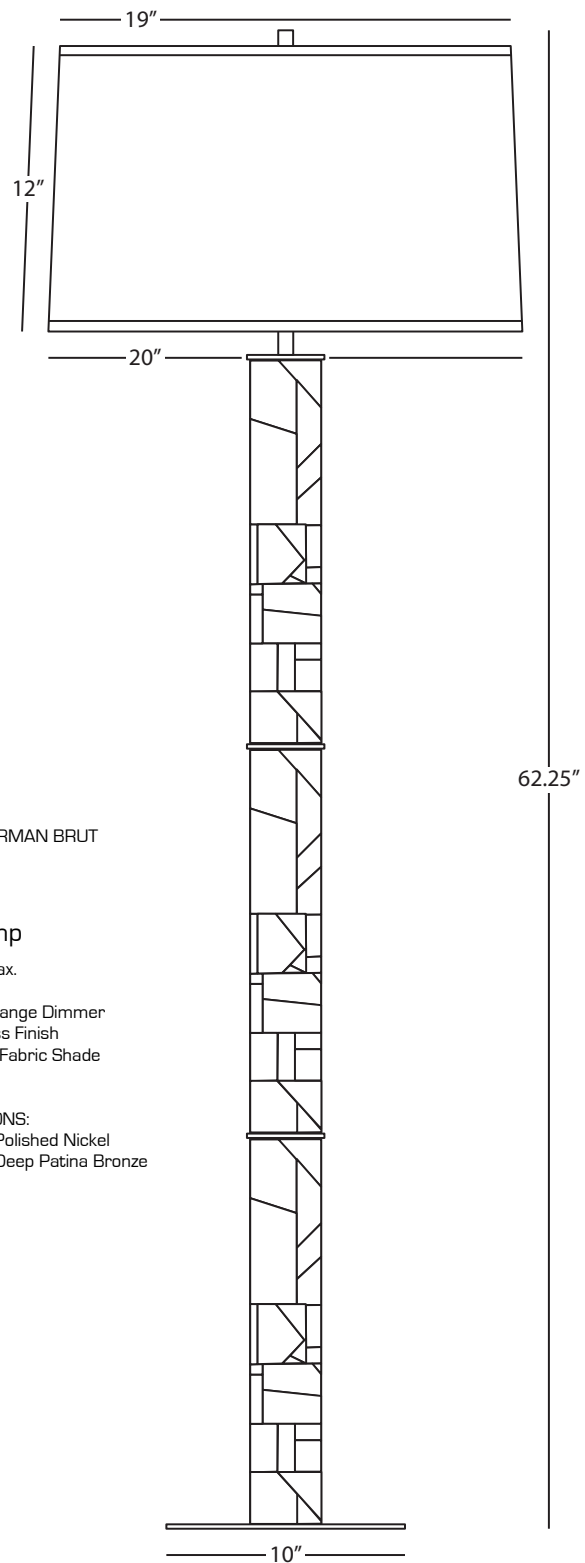

MICHAEL BERMAN BRUT

628

Floor Lamp

1 - 150W Max.
Bulb Type: A
Switch: Full Range Dimmer
Modern Brass Finish
Ascot White Fabric Shade

FINISH OPTIONS:

S628 Polished Nickel
Z628 Deep Patina Bronze



626



S624



Z626



623

Michael Berman Brut

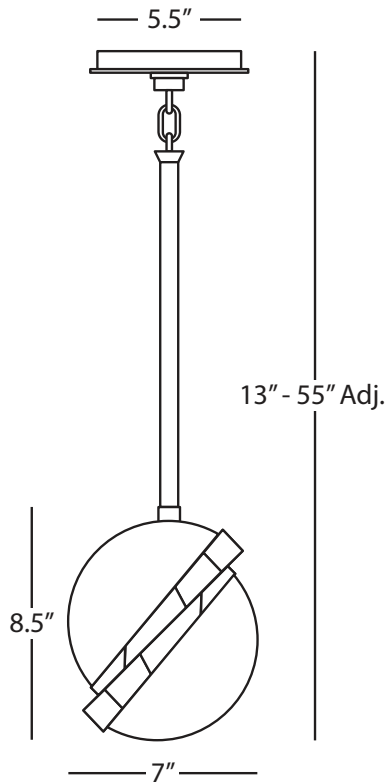

MICHAEL BERMAN BRUT

S624

Pendant

1 - 60W Max.
 Bulb Type: B, Medium Base
 Direct Wire
 Polished Nickel Finish
 Cased White Glass Shade
 Susp. Hardware: 1 pc. 5/8" x 6" & 3 pcs.
 5/8" x 12" Extensions

FINISH OPTIONS:

624 Modern Brass
Z624 Deep Patina Bronze

MICHAEL BERMAN BRUT

623

Flush Mount

1 - 60W Max.
 Bulb Type: B, Medium Base
 Direct Wire
 Modern Brass Finish
 Cased White Glass Shade

FINISH OPTIONS:

S623 Polished Nickel
Z623 Deep Patina Bronze

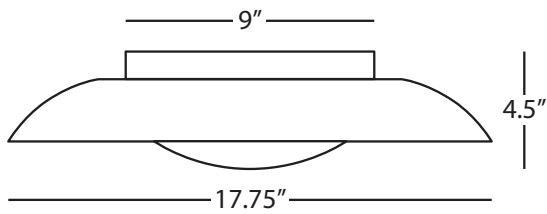
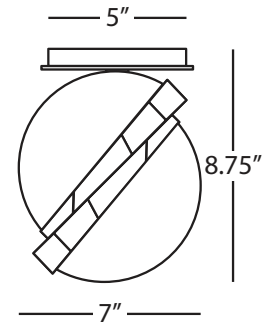

MICHAEL BERMAN BRUT

626

Disc Flush Mount/Sconce

1 - 15W
 (1200 Lumen Output)
 Bulb Type: LED unit, Included (Non-replaceable)
 LED Color Temp: 3000K, CRI: 90
 Direct Wire Only
 Modern Brass Finish

FINISH OPTIONS:

S626 Polished Nickel
Z626 Deep Patina Bronze

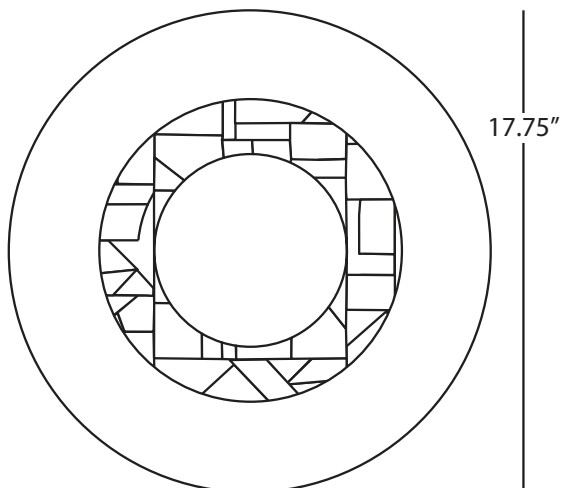



MDC27



MWR26



MDV28



MMB27



MCR26



MSB28

Michael Berman Hadrian

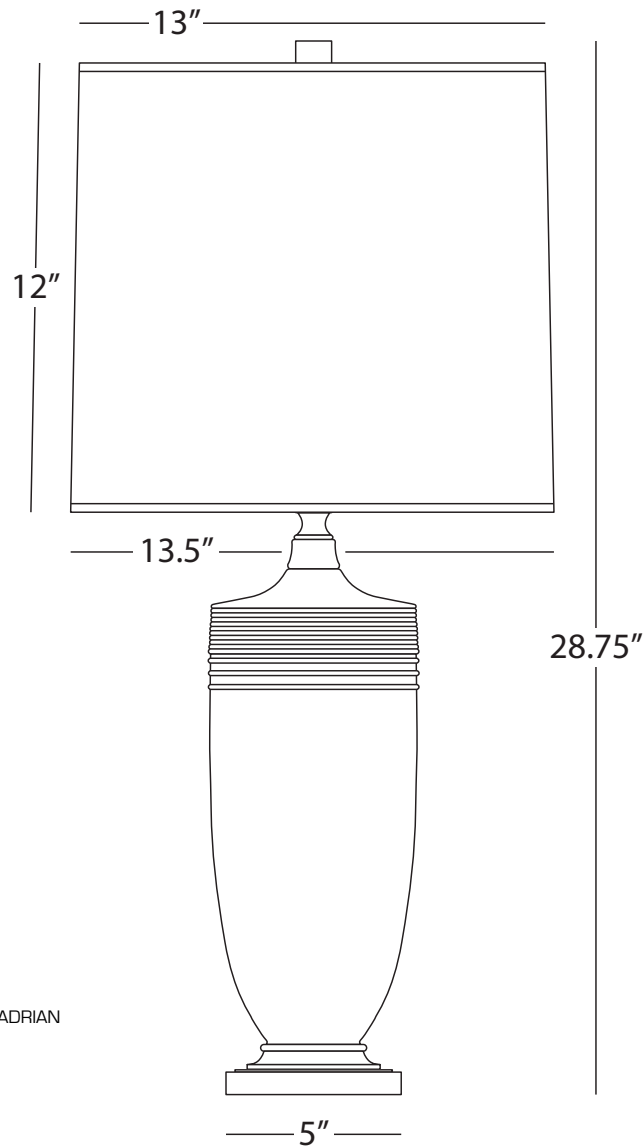

MICHAEL BERMAN HADRIAN

MCR26

Table Lamp

1 - 150W Max.
Bulb Type: A
Switch: Hi-Lo Dimming
Matte Ash Glazed Ceramic
Dark Antique Nickel Accents
Oyster Linen Shade

See Page 508 for Color/Base Options



MDC25



MWR24



MMB23



MLY25



MSB23



MCR24

Michael Berman Nolan

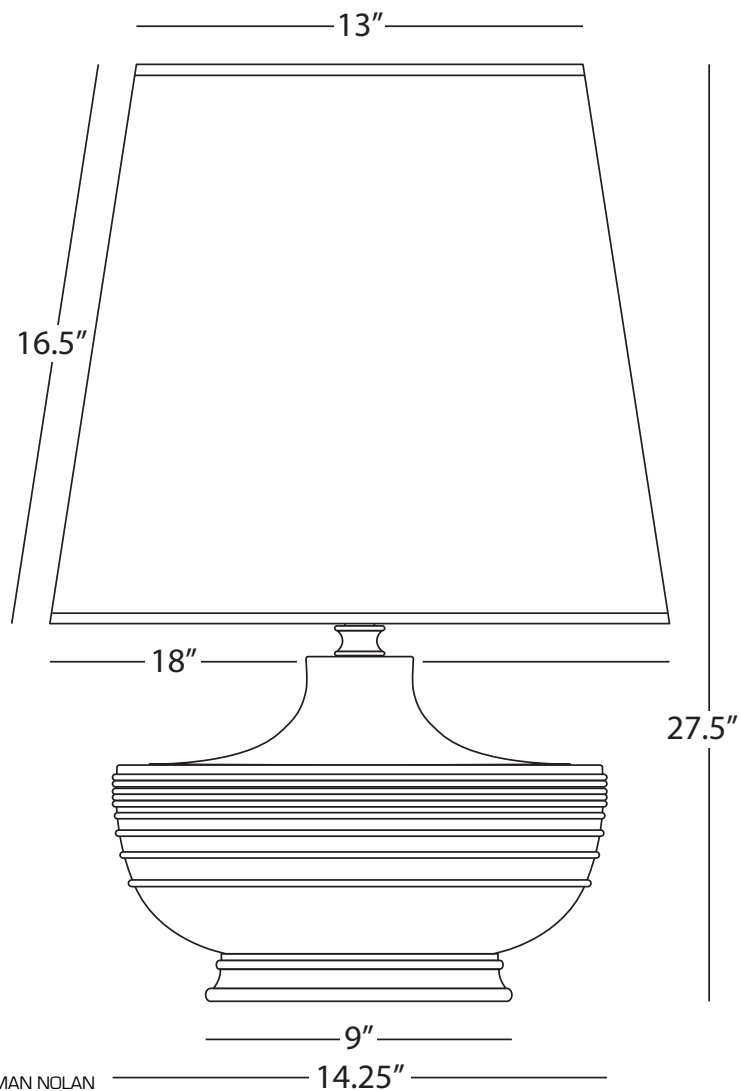

MICHAEL BERMAN NOLAN

MCR24

Table Lamp

1 - 150W Max.
Bulb Type: A
Switch: Hi-Lo Dimming
Matte Ash Glazed Ceramic
Modern Brass Accents
Oyster Linen Shade

See Page 508 for Color/Base Options



BULG1



BULS1



BULO1



HISO1

Bulbs

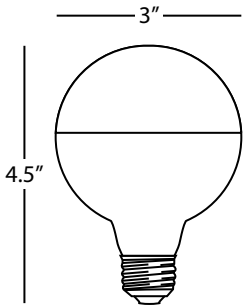

BULBS

BULG1

Gold Tip Bulb

1 - 40W
G25, Medium Base Bulb

OPTION:

BUL6G 6 - 40W Gold Tip Bulbs

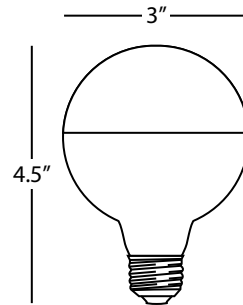

BULBS

BULS1

Silver Tip Bulb

1 - 40W
G25, Medium Base Bulb

OPTION:

BUL6S 6 - 40W Silver Tip Bulbs

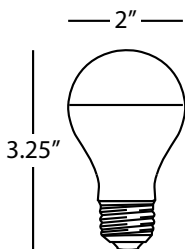

BULBS

BULO1

Silver Tip Bulb

1 - 60W
A15, Medium Base Bulb

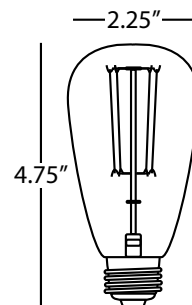

BULBS

HIS01

Historical Bulb

1 - 40W
Medium Base
1910 Squirrel Cage Filament Bulb

OPTIONS:

BUL06 6 - 40W Historical Bulbs

BUL09 9 - 40W Historical Bulbs

BUL12 12 - 40W Historical Bulbs

BUL18 18 - 40W Historical Bulbs

BUL30 30 - 40W Historical Bulbs

Matte Ceramics

All ceramic styles now available in matte glazes



MLY99



MCR09



MMB97



MST70



MOB91



MCL90



MCF08

Matte Ceramics

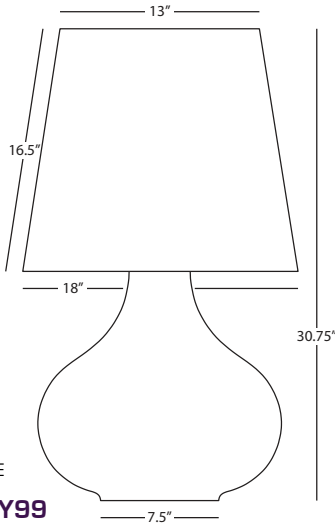

JUNE
MLY99
Table Lamp

1 - 150W Max.
Bulb Type: A
Switch: Hi-Lo Dimming
Matte Lily Glazed Ceramic
Oyster Linen Shade

FINISH OPTIONS:
See June Color Chart

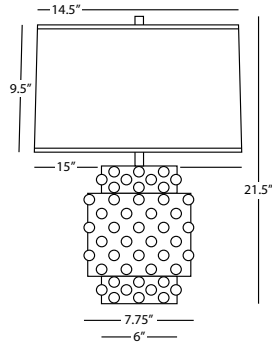

DOLLY
MCR09
Accent Lamp

1 - 150W Max.
Bulb Type: A
Switch: Full Range Dimmer
Matte Ash Glazed Textured Ceramic
Fondine Fabric Shade

FINISH OPTIONS:
See Dolly Color Chart

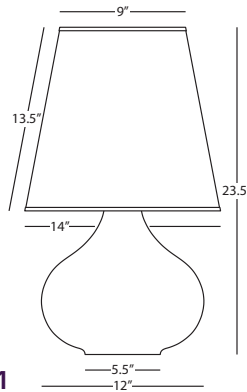
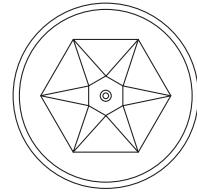

JUNE
MOB91
Accent Lamp

1 - 150W Max.
Bulb Type: A
Switch: Full Range Dimmer Line Switch
Matte Steel Blue Glazed Ceramic
Buff Linen Shade

FINISH OPTIONS:
See June Color Chart

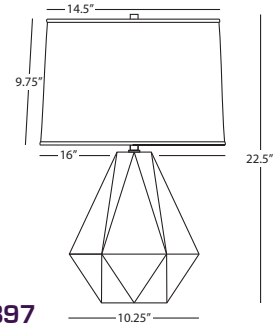

DELTA
MMB97
Table Lamp

1 - 150W Max.
Bulb Type: A
Switch: 3-Way Switch
Matte Midnight Blue Glazed Ceramic
Polished Nickel Accents
Oyster Linen Shade

FINISH OPTIONS:
See Delta Color Chart

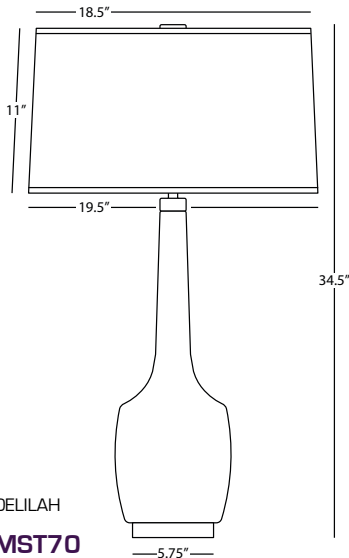

DELILAH
MST70
Table Lamp

1 - 150W Max.
Bulb Type: A
Switch: Hi-Lo Dimming
Matte Smoky Taupe Glazed Ceramic
Oyster Linen Shade with Self-Fabric Top and
Bottom Diffusers

FINISH OPTIONS:
See Delilah Color Chart

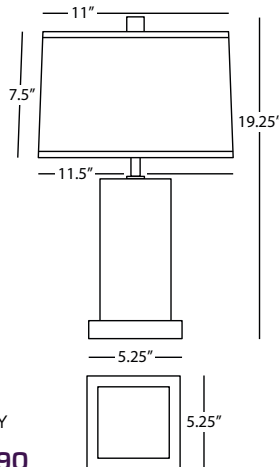

HARVEY
MCL90
Accent Lamp

1 - 60W Max.
Bulb Type: G16.5 Candelabra
Switch: Hi-Lo Dimming
Matte Celedon Glazed Ceramic
Lucite Base
Oyster Linen Shade with Self-Fabric Top Diffuser

FINISH OPTIONS:
See Harvey Color Chart

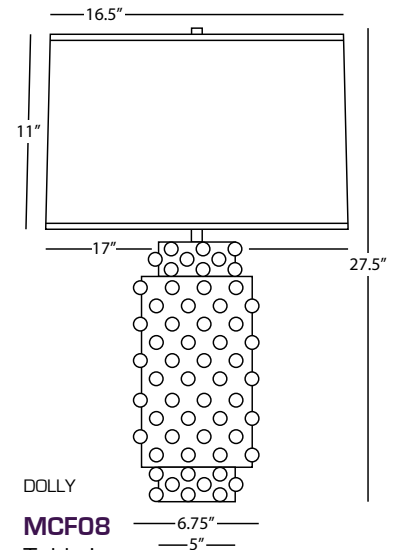

DOLLY
MCF08
Table Lamp

1 - 150W Max.
Bulb Type: A
Switch: Full Range Dimmer
Matte Coffee Glazed Textured Ceramic
Fondine Fabric Shade

FINISH OPTIONS:
See Dolly Color Chart

Matte Ceramics

All ceramic styles now available in matte glaze



MCL53



MOB41



MST95



MCF17



MLY96



MST30



MCL10



MCF02



MLY81



MMB18



MCL03



MOB60



MCR62

Matte Ceramics

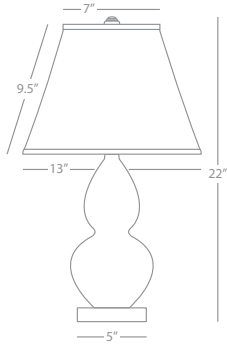

SMALL DOUBLE GOURD

MCL53
Accent Lamp

1 - 150W Max.
Bulb Type: A
Switch: 3-Way
Matte Caledon Glazed Ceramic
Lucite Base
Pearl Dupioni Fabric Shade

FINISH OPTIONS:
See Color Chart

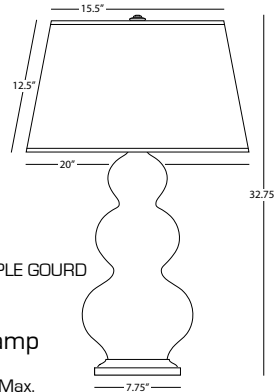

LARGE TRIPLE GOURD

MOB41
Table Lamp

1 - 150W Max.
Bulb Type: A
Switch: 3-Way
Matte Steel Blue Glazed Ceramic
Bronze Base
Pearl Dupioni Fabric Shade

FINISH OPTIONS:
See Color Chart

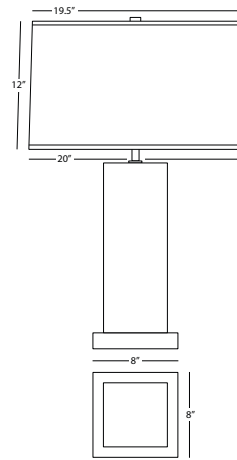

HARVEY

MST95
Table Lamp

1 - 150W Max.
Bulb Type: A
Switch: Hi-Lo Dimming
Matte Smoky Taupe Glazed Ceramic
Oyster Linen Fabric Shade

FINISH OPTIONS:
See Color Chart

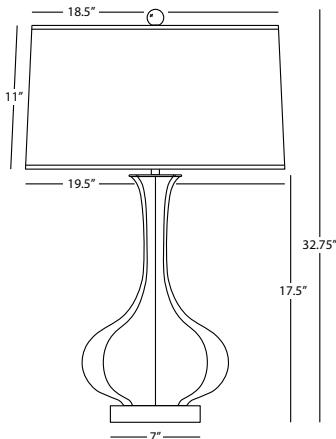
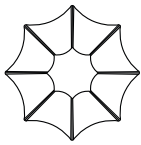

PIKE

MLY96
Table Lamp

1 - 150W Max.
Bulb Type: A
Switch: Hi-Lo Dimming
Matte Lily Glazed Ceramic
Lucite Base
Pearl Dupioni Fabric Shade

FINISH OPTIONS:
See Color Chart

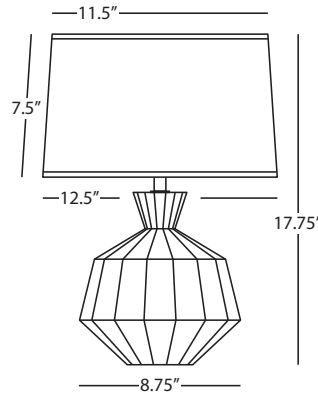

ORION

MCF17
Table Lamp

1 - 150W Max.
Bulb Type: A
Switch: Hi-Lo Dimming
Matte Coffee Glazed Ceramic
Oyster Linen Fabric Shade
Self Fabric Top Diffuser

FINISH OPTIONS:
See Color Chart

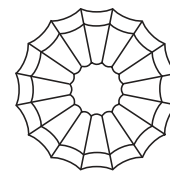

SMALL TRIPLE GOURD

MLY96
Accent Lamp

1 - 150W Max.
Bulb Type: A
Switch: 3-Way
Matte Smoky Taupe Glazed Ceramic
Brass Base
Pearl Dupioni Fabric Shade

FINISH OPTIONS:
See Color Chart

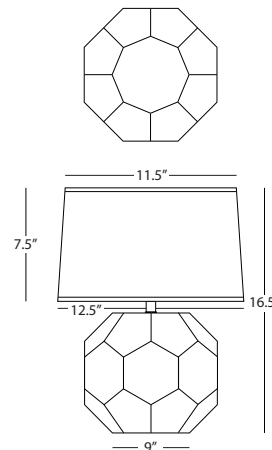
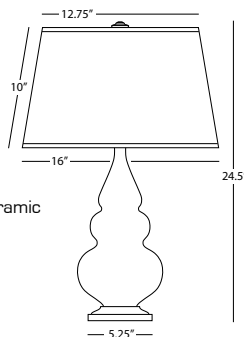

FRANKLIN

MCF02
Accent Lamp

1 - 60W Max.
Bulb Type: A
Switch: Full Range Dimmer Line Switch
Matte Coffee Glazed Ceramic
Oyster Linen Shade with Self-Fabric Diffuser

FINISH OPTIONS:
See Color Chart

Matte Ceramics

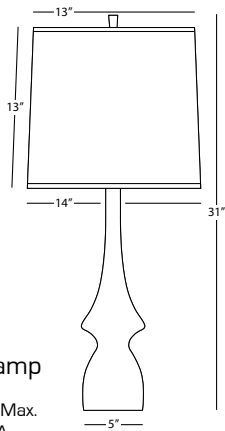

JASMINE

MCL10 Table Lamp

1 - 150W Max.
Bulb Type: A
Switch: Hi-Lo Dimming
Matte Celedon Glazed Ceramic
Oyster Linen Fabric Shade

FINISH OPTIONS:
See Color Chart

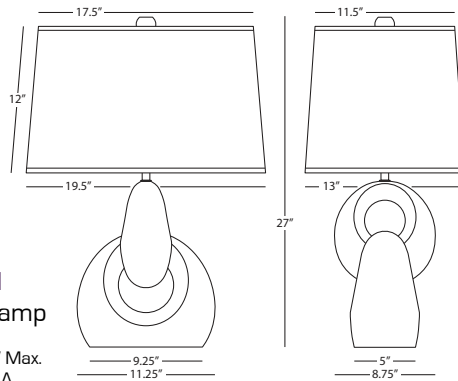

FUSION

MLY81 Table Lamp

1 - 150W Max.
Bulb Type: A
Switch: Full Range Dimmer
Matte Lily Glazed Ceramic
Polished Nickel Accents
Oval, Oyster Linen Fabric Shade

FINISH OPTIONS:
See Color Chart

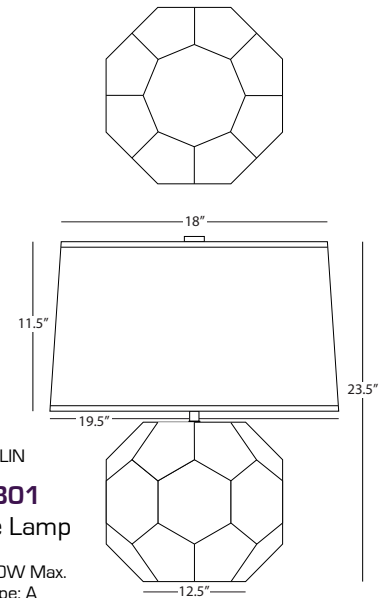

FRANKLIN

MMB01 Table Lamp

1 - 150W Max.
Bulb Type: A
Switch: Full Range Dimmer
Matte Midnight Blue Glazed Ceramic
Oyster Linen Shade with Self-Fabric
Diffuser

FINISH OPTIONS:
See Color Chart

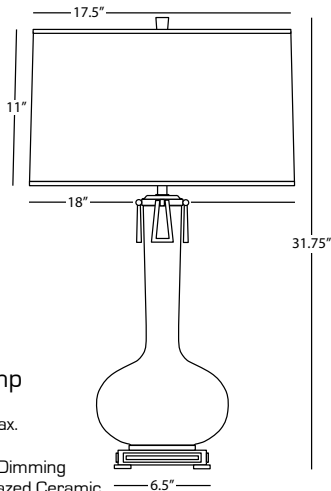

ATHENA

MCR92 Table Lamp

1 - 150W Max.
Bulb Type: A
Switch: Hi-Lo Dimming
Matte Ash Glazed Ceramic
Cast Metal Base and Ring Details
Aged Brass Finish
Open Weave Heather Linen Shade

FINISH OPTIONS:
See Color Chart

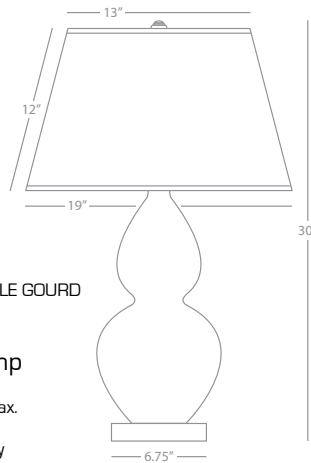

LARGE DOUBLE GOURD

MCR62 Table Lamp

1 - 150W Max.
Bulb Type: A
Switch: 3-Way
Matte Ash Glazed Ceramic
Lucite Base
Pearl Dupioni Fabric Shade

FINISH OPTIONS:
See Color Chart

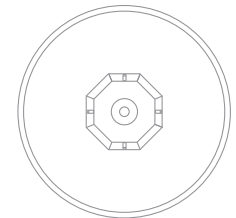

MASON

MOB60 Table Lamp

1 - 150W Max.
Bulb Type: A
Switch: 3-Way
Matte Steel Blue Glazed Ceramic
Polished Nickel Accents
Oyster Linen Fabric Shade

FINISH OPTIONS:
See Color Chart

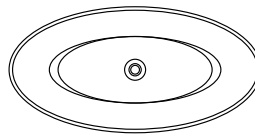

AUDREY

MCR80 Table Lamp

1 - 150W Max.
Bulb Type: A
Switch: Hi-Lo Dimming
Matte Ash Glazed Ceramic
Lucite Base
Fondine Fabric Shade

FINISH OPTIONS:
See Color Chart

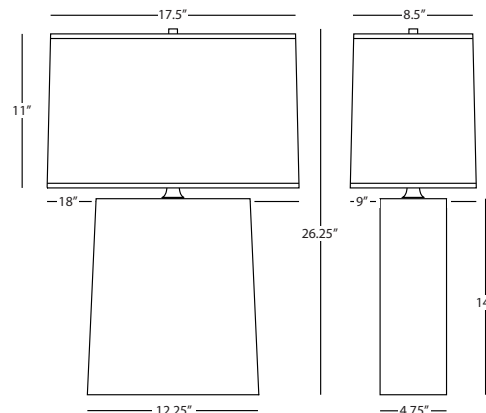

VICTOR

MCL03 Table Lamp

1 - 100W Max.
Bulb Type: A
Switch: Full Range Dimmer
Matte Celedon Glazed Ceramic
Oval Ascot White Shade

FINISH OPTIONS:
See Color Chart

Athena | Audrey



ATHENA TABLE LAMP

● AMETHYST	AM992
● APPLE	AP992
● ASH	CR992
● BABY BLUE	BB992
● BONE	BN992
● BROWN TEA	TE992
● BUTTER	BT992
● CELADON	CL992
● CINNAMON	CM992
● CITRON	CI992
● COFFEE	CF992
● EGG BLUE	EB992
● EMERALD	EG992
○ LILY	LY992
● MARINE BLUE	MR992
● MELON	ML992
● MIDNIGHT BLUE	MB992
● OXBLOOD	OX992
● PEACOCK	PC992
● PUMPKIN	PM992
● RUBY RED	RR992
● SCHIAPARELLI PINK	SP992
● SMOKY TAUPE	ST992
● STEEL BLUE	OB992
● SUNSET YELLOW	SU992

MATTE COLORS

● MATTE ASH	MCR92
● MATTE CELEDON	MCL92
● MATTE COFFEE	MCF92
○ MATTE LILY	MLY92
● MATTE MIDNIGHT BLUE	MMB92
● MATTE SMOKY TAUPE	MST92
● MATTE STEEL BLUE	MOB92

AUDREY TABLE LAMP

● AMETHYST	AM980
● APPLE	AP980
● ASH	CR980
● BABY BLUE	BB980
● BONE	BN980
● BROWN TEA	TE980
● BUTTER	BT980
● CELADON	CL980
● CINNAMON	CM980
● CITRON	CI980
● COFFEE	CF980
● EGG BLUE	EB980
● EMERALD	EG980
○ LILY	LY980
● MARINE BLUE	MR980
● MELON	ML980
● MIDNIGHT BLUE	MB980
● OXBLOOD	OX980
● PEACOCK	PC980
● PUMPKIN	PM980
● RUBY RED	RR980
● SCHIAPARELLI PINK	SP980
● SMOKY TAUPE	ST980
● STEEL BLUE	OB980
● SUNSET YELLOW	SU980

MATTE COLORS

● MATTE ASH	MCR80
● MATTE CELEDON	MCL80
● MATTE COFFEE	MCF80
○ MATTE LILY	MLY80
● MATTE MIDNIGHT BLUE	MMB80
● MATTE SMOKY TAUPE	MST80
● MATTE STEEL BLUE	MOB80



Delilah | Delta



DELILAH TABLE LAMP

● AMETHYST	AM701
● APPLE	AP701
● ASH	CR701
● BABY BLUE	BB701
○ BONE	BN701
● BROWN TEA	TE701
● BUTTER	BT701
● CELADON	CL701
● CINNAMON	CM701
● CITRON	CI701
● COFFEE	CF701
● EGG BLUE	EB701
● EMERALD	EG701
○ LILY	LY701
● MARINE BLUE	MR701
● MELON	ML701
● MIDNIGHT BLUE	MB701
● OXBLOOD	OX701
● PEACOCK	PC701
● PUMPKIN	PM701
● RUBY RED	RR701
● SCHIAPARELLI PINK	SP701
● SMOKY TAUPE	ST701
● STEEL BLUE	OB701
● SUNSET YELLOW	SU701

MATTE COLORS

● MATTE ASH	MCR70
● MATTE CELEDON	MCL70
● MATTE COFFEE	MCF70
○ MATTE LILY	MLY70
● MATTE MIDNIGHT BLUE	MMB70
● MATTE SMOKY TAUPE	MST70
● MATTE STEEL BLUE	MOB70

DELTA TABLE LAMP

● AMETHYST	949
● APPLE	935
● ASH	CR930
● BABY BLUE	936
○ BONE	930
● BROWN TEA	TE930
● BUTTER	940
● CELADON	947
● CINNAMON	944
● CITRON	CI930
● COFFEE	CF930
● EGG BLUE	943
● EMERALD	EG930
○ LILY	932
● MARINE BLUE	946
● MELON	ML930
● MIDNIGHT BLUE	MB930
● OXBLOOD	938
● PEACOCK	934
● PUMPKIN	933
● RUBY RED	RR930
● SCHIAPARELLI PINK	941
● SMOKY TAUPE	942
● STEEL BLUE	OB930
● SUNSET YELLOW	SU930

MATTE COLORS

● MATTE ASH	MCR97
● MATTE CELEDON	MCL97
● MATTE COFFEE	MCF97
○ MATTE LILY	MLY97
● MATTE MIDNIGHT BLUE	MMB97
● MATTE SMOKY TAUPE	MST70
● MATTE STEEL BLUE	MOB70





DOLLY ACCENT LAMP

● AMETHYST	AM801
● APPLE	AP801
● ASH	CR801
● BABY BLUE	BB801
● BONE	BN801
● BROWN TEA	TE801
● BUTTER	BT801
● CELADON	CL801
● CINNAMON	CM801
● CITRON	CI801
● COFFEE	CF801
● EGG BLUE	EB801
● EMERALD	EG801
○ LILY	LY801
● MARINE BLUE	MR801
● MELON	ML801
● MIDNIGHT BLUE	MB801
● OXBLOOD	OX801
● PEACOCK	PC801
● PUMPKIN	PM801
● RUBY RED	RR801
● SCHIAPARELLI PINK	SP801
● SMOKY TAUPE	ST801
● STEEL BLUE	OB801
● SUNSET YELLOW	SU801

MATTE COLORS

● MATTE ASHE	MCR09
● MATTE CELEDON	MCL09
● MATTE COFFEE	MCF09
○ MATTE LILY	MLY09
● MATTE MIDNIGHT BLUE	MMB09
● MATTE SMOKY TAUPE	MST09
● MATTE STEEL BLUE	MOB09

DOLLY TABLE LAMP

● AMETHYST	AM800
● APPLE	AP800
● ASH	CR800
● BABY BLUE	BB800
● BONE	BN800
● BROWN TEA	TE800
● BUTTER	BT800
● CELADON	CL800
● CINNAMON	CM800
● CITRON	CI800
● COFFEE	CF800
● EGG BLUE	EB800
● EMERALD	EG800
○ LILY	LY800
● MARINE BLUE	MR800
● MELON	ML800
● MIDNIGHT BLUE	MB800
● OXBLOOD	OX800
● PEACOCK	PC800
● PUMPKIN	PM800
● RUBY RED	RR800
● SCHIAPARELLI PINK	SP800
● SMOKY TAUPE	ST800
● STEEL BLUE	OB800
● SUNSET YELLOW	SU800

MATTE COLORS

● MATTE ASH	MCR08
● MATTE CELEDON	MCL08
● MATTE COFFEE	MCF08
○ MATTE LILY	MLY08
● MATTE MIDNIGHT BLUE	MMB08
● MATTE SMOKY TAUPE	MST08
● MATTE STEEL BLUE	MOB08



Double Gourd



LARGE DOUBLE GOURD

- AMETHYST
- APPLE
- ASH
- BABY BLUE
- BONE
- BROWN TEA
- BUTTER
- CELADON
- CINNAMON
- CITRON
- COFFEE
- EGG BLUE
- EMERALD
- LILY
- MARINE BLUE
- MELON
- MIDNIGHT BLUE
- OXBLOOD
- PEACOCK
- PUMPKIN
- RUBY RED
- SCHIAPARELLI PINK
- SMOKY TAUPE
- STEEL BLUE
- SUNSET YELLOW

BRASS BASE

- 1745, 1745X
- 1663, 1663X
- CR20, CR20X
- 1666, 1666X
- 1754, 1754X
- TE20, TE20X
- 1604, 1604X
- 1789, 1789X
- 1757, 1757X
- CI20, CI20C
- CF20, CF20X
- 1740, 1740X
- EG20, EG20X
- 1660, 1660X
- 1783, 1783X
- ML20, ML20X
- MB20, MB20X
- 1667, 1667X
- 1751, 1751X
- 1665, 1665X
- RR20, RR20X
- 1607, 1607X
- 1748, 1748X
- OB20, OB20X
- SU20, SU20X

BRONZE BASE

- 1746, 1746X
- 1643, 1643X
- CR21, CR21X
- 1646, 1646X
- 1755, 1755X
- TE21, TE21X
- 1605, 1605X
- 1790, 1790X
- 1758, 1758X
- CI21, CI21X
- CF21, CF21X
- EG21, EG21X
- 1640, 1640X
- ML21, ML21X
- MB21, MB21X
- 1647, 1647X
- 1752, 1752X
- 1645, 1645X
- RR21, RR21X
- 1608, 1608X
- 1749, 1749X
- OB21, OB21X
- SU21, SU21X

ANT. SILVER BASE

- 1747, 1747X
- 1673, 1673X
- CR22, CR22X
- 1676, 1676X
- 1756, 1756X
- TE22, TE22X
- 1606, 1606X
- 1791, 1791X
- 1759, 1759X
- CI22, CI22X
- CF22, CF22X
- 1741, 1741X
- EG22, EG22X
- 1670, 1670X
- 1785, 1785X
- ML22, ML22X
- MB22, MB22X
- 1753, 1753X
- 1675, 1675X
- RR22, RR22X
- 1609, 1609X
- 1750, 1750X
- OB22, OB22X
- SU22, SU22X

LUCITE BASE

- A747, A747X
- A673, A673X
- CR23, CR23X
- A676, A676X
- A756, A756X
- TE23, TE23X
- A606, A606X
- A791, A791X
- A759, A759X
- CI23, CI23X
- CF23, CF23X
- A741, A741X
- EG23, EG23X
- A670, A670X
- A785, A785X
- ML23, ML23X
- MB23, MB23X
- A627, A627X
- A753, A753X
- A675, A675X
- RR23, RR23X
- A609, A609X
- A750, A750X
- OB23, OB23X
- SU23, SU23X

MATTE COLORS

- MATTE ASH
- MATTE CELEDON
- MATTE COFFEE
- MATTE LILY
- MATTE MIDNIGHT BLUE
- MATTE SMOKY TAUPE
- MATTE STEEL BLUE

- MCR54, MCR55
- MCL54, MCL55
- MCF54, MCF55
- MLY54, MLY55
- MMB54, MMB54
- MST54, MST54
- MOB54, MOB54

- MCR56, MCR57
- MCL56, MCL57
- MCF56, MCF57
- MLY56, MLY57
- MMB56, MMB57
- MST56, MST57
- MOB56, MOB57

- MCR58, MCR59
- MCL58, MCL59
- MCF58, MCF59
- MLY58, MLY59
- MMB58, MMB59
- MST58, MST59
- MOB58, MOB59

- MCR61, MCR62
- MCL61, MCL62
- MCF61, MCF62
- MLY61, MLY62
- MMB61, MMB62
- MST61, MST62
- MOB61, MOB62



Double Gourd



SMALL DOUBLE GOURD

- AMETHYST
- APPLE
- ASH
- BABY BLUE
- BONE
- BROWN TEA
- BUTTER
- CELADON
- CINNAMON
- CITRON
- COFFEE
- EGG BLUE
- EMERALD
- LILY
- MARINE BLUE
- MELON
- MIDNIGHT BLUE
- OXBLOOD
- PEACOCK
- PUMPKIN
- RUBY RED
- SCHIAPARELLI PINK
- SMOKY TAUPE
- STEEL BLUE
- SUNSET YELLOW

BRASS BASE

- 1765, 1765X
- 1683, 1683X
- CR10, CR10X
- 1689, 1689X
- 1774, 1774X
- TE10, TE10X
- 1614, 1614X
- 1786, 1786X
- 1777, 1777X
- CI10, CI10X
- CF10, CF10X
- 1760, 1760X
- EG10, EG10X
- 1680, 1680X
- 1780, 1780X
- ML10, ML10X
- MB10, MB10X
- 1687, 1687X
- 1771, 1771X
- 1685, 1685X
- RR10, RR10X
- 1617, 1617X
- 1768, 1768X
- OB10, OB10X
- SU10, SU10X

BRONZE BASE

- 1766, 1766X
- 1653, 1653X
- CR11, CR11X
- 1656, 1656X
- 1775, 1775X
- TE11, TE11X
- 1615, 1615X
- 1787, 1787X
- 1778, 1778X
- CI11, CI11X
- CF11, CF11X
-
- EG11, EG11X
- 1650, 1650X
-
- ML11, ML11X
- MB11, MB11X
- 1657, 1657X
- 1772, 1772X
- 1655, 1655X
- RR11, RR11X
- 1618, 1618X
- 1769, 1769X
- OB11, OB11X
- SU11, SU11X

ANT. SILVER BASE

- 1767, 1767X
- 1693, 1693X
- CR12, CR12X
- 1696, 1696X
- 1776, 1776X
- TE12, TE12X
- 1616, 1616X
- 1788, 1788X
- 1779, 1779X
- CI12, CI12X
- CF12, CF12X
- 1761, 1761X
- EG12, EG12X
- 1690, 1690X
- 1782, 1782X
- ML12, ML12X
- MB12, MB12X
-
- 1773, 1773X
- 1695, 1695X
- RR12, RR12X
- 1619, 1619X
- 1770, 1770X
- OB12, OB12X
- SU12, SU12X

LUCITE BASE

- A767, A767X
- A693, A693X
- CR13, CR13X
- A696, A696X
- A776, A776X
- TE13, TE13X
- A616, A616X
- A788, A788X
- A779, A779X
- CI13, CI13X
- CF13, CF13X
- A761, A761X
- EG13, EG13X
- A690, A690X
- A782, A782X
- ML13, ML13X
- MB13, MB13X
- A697, A697X
- A773, A773X
- A695, A695X
- RR13, RR13X
- A619, A619X
- A770, A770X
- OB13, OB13X
- SU13, SU13X

MATTE COLORS

- MATTE ASH
- MATTE CELEDON
- MATTE COFFEE
- MATTE LILY
- MATTE MIDNIGHT BLUE
- MATTE SMOKY TAUPE
- MATTE STEEL BLUE

- MCR14, MCR50
- MCL14, MCL50
- MCF14, MCF50
- MLY14, MLY50
- MMB14, MMB50
- MST14, MST50
- MOB14, MOB50

- MCR11, MCR51
- MCL11, MCL51
- MCF11, MCF51
- MLY11, MLY51
- MMB11, MMB51
- MST11, MST51
- MOB11, MOB51

- MCR12, MCR52
- MCL12, MCL52
- MCF12, MCF52
- MLY12, MLY52
- MMB12, MMB52
- MST12, MST52
- MOB12, MOB52

- MCR13, MCR53
- MCL13, MCL53
- MCF13, MCF53
- MLY13, MLY53
- MMB13, MMB53
- MST13, MST53
- MOB13, MOB53



Franklin



FRANKLIN ACCENT LAMP

● AMETHYST	AM02
● APPLE	AP02
● ASH	CR02
● BABY BLUE	BB02
● BONE	BN02
● BROWN TEA	TE02
● BUTTER	BT02
● CELADON	CLO2
● CINNAMON	CM02
● CITRON	CI02
● COFFEE	CF02
● EGG BLUE	EB02
● EMERALD	EG02
○ LILY	LY02
● MARINE BLUE	MR02
● MELON	ML02
● MIDNIGHT BLUE	MB02
● OXBLOOD	OX02
● PEACOCK	PC02
● PUMPKIN	PM02
● RUBY RED	RR02
● SCHIAPARELLI PINK	SP02
● SMOKY TAUPE	ST02
● STEEL BLUE	OB02
● SUNSET YELLOW	SU02

MATTE COLORS

● MATTE ASH	MCR02
● MATTE CELADON	MCL02
● MATTE COFFEE	MCF02
○ MATTE LILY	MLY02
● MATTE MIDNIGHT BLUE	MMB02
● MATTE SMOKY TAUPE	MST02
● MATTE STEEL BLUE	MOB02

FRANKLIN TABLE LAMP

● AMETHYST	AM01
● APPLE	AP01
● ASH	CR01
● BABY BLUE	BB01
● BONE	BN01
● BROWN TEA	TE01
● BUTTER	BT01
● CELADON	CLO1
● CINNAMON	CM01
● CITRON	CI01
● COFFEE	CF01
● EGG BLUE	EB01
● EMERALD	EG01
○ LILY	LY01
● MARINE BLUE	MR01
● MELON	ML01
● MIDNIGHT BLUE	MB01
● OXBLOOD	OX01
● PEACOCK	PC01
● PUMPKIN	PM01
● RUBY RED	RR01
● SCHIAPARELLI PINK	SP01
● SMOKY TAUPE	ST01
● STEEL BLUE	OB01
● SUNSET YELLOW	SU01

MATTE COLORS

● MATTE ASH	MCR01
● MATTE CELADON	MCL01
● MATTE COFFEE	MCF01
○ MATTE LILY	MLY01
● MATTE MIDNIGHT BLUE	MMB01
● MATTE SMOKY TAUPE	MST01
● MATTE STEEL BLUE	MOB01



Fusion | Jasmine



FUSION TABLE LAMP

● AMETHYST	AM981
● APPLE	AP981
● ASH	CR981
● BABY BLUE	BB981
○ BONE	BN981
● BROWN TEA	TE981
● BUTTER	BT981
● CELADON	CL981
● CINNAMON	CM981
● CITRON	CI981
● COFFEE	CF981
● EGG BLUE	EB981
● EMERALD	EG981
○ LILY	LY981
● MARINE BLUE	MR981
● MELON	ML981
● MIDNIGHT BLUE	MB981
● OXBLOOD	OX981
● PEACOCK	PC981
● PUMPKIN	PM981
● RUBY RED	RR981
● SCHIAPARELLI PINK	SP981
● SMOKY TAUPE	ST981
● STEEL BLUE	OB981
● SUNSET YELLOW	SU981

MATTE COLORS

● MATTE ASH	MCR81
● MATTE CELEDON	MCL81
● MATTE COFFEE	MCF81
○ MATTE LILY	MLY81
● MATTE MIDNIGHT BLUE	MMB81
● MATTE SMOKY TAUPE	MST81
● MATTE STEEL BLUE	MOB81

JASMINE TABLE LAMP

● AMETHYST	AM210
● APPLE	AP210
● ASH	CR210
● BABY BLUE	BB210
○ BONE	BN210
● BROWN TEA	TE210
● BUTTER	BT210
● CELADON	CL210
● CINNAMON	CM210
● CITRON	CI210
● COFFEE	CF210
● EGG BLUE	EB210
● EMERALD	EG210
○ LILY	LY210
● MARINE BLUE	MR210
● MELON	ML210
● MIDNIGHT BLUE	MB210
● OXBLOOD	OX210
● PEACOCK	PC210
● PUMPKIN	PM210
● RUBY RED	RR210
● SCHIAPARELLI PINK	SP210
● SMOKY TAUPE	ST210
● STEEL BLUE	OB210
● SUNSET YELLOW	SU210

MATTE COLORS

● MATTE ASH	MCR10
● MATTE CELEDON	MCL10
● MATTE COFFEE	MCF10
○ MATTE LILY	MLY10
● MATTE MIDNIGHT BLUE	MMB10
● MATTE SMOKY TAUPE	MST10
● MATTE STEEL BLUE	MOB10



Harvey



HARVEY ACCENT LAMP

● AMETHYST	AM990
● APPLE	AP990
● ASH	CR990
● BABY BLUE	BB990
● BONE	BN990
● BROWN TEA	TE990
● BUTTER	BT990
● CELADON	CL990
● CINNAMON	CM990
● CITRON	CI990
● COFFEE	CF990
● EGG BLUE	EB990
● EMERALD	EG990
○ LILY	LY990
● MARINE BLUE	MR990
● MELON	ML990
● MIDNIGHT BLUE	MB990
● OXBLOOD	OX990
● PEACOCK	PC990
● PUMPKIN	PM990
● RUBY RED	RR990
● SCHIAPARELLI PINK	SP990
● SMOKY TAUPE	ST990
● STEEL BLUE	OB990
● SUNSET YELLOW	SU990

MATTE COLORS

● MATTE ASH	MCR90
● MATTE CELEDON	MCL90
● MATTE COFFEE	MCF90
○ MATTE LILY	MLY90
● MATTE MIDNIGHT BLUE	MMB90
● MATTE SMOKY TAUPE	MST90
● MATTE STEEL BLUE	MOB90

HARVEY TABLE LAMP

● AMETHYST	AM995
● APPLE	AP995
● ASH	CR995
● BABY BLUE	BB995
● BONE	BN995
● BROWN TEA	TE995
● BUTTER	BT995
● CELADON	CL995
● CINNAMON	CM995
● CITRON	CI995
● COFFEE	CF995
● EGG BLUE	EB995
● EMERALD	EG995
○ LILY	LY995
● MARINE BLUE	MR995
● MELON	ML995
● MIDNIGHT BLUE	MB995
● OXBLOOD	OX995
● PEACOCK	PC995
● PUMPKIN	PM995
● RUBY RED	RR995
● SCHIAPARELLI PINK	SP995
● SMOKY TAUPE	ST995
● STEEL BLUE	OB995
● SUNSET YELLOW	SU995

MATTE COLORS

● MATTE ASH	MCR95
● MATTE CELEDON	MCL95
● MATTE COFFEE	MCF95
○ MATTE LILY	MLY95
● MATTE MIDNIGHT BLUE	MMB95
● MATTE SMOKY TAUPE	MST95
● MATTE STEEL BLUE	MOB95





JUNE ACCENT LAMP

	BUFF SHADE	OYSTER SHADE
● AMETHYST	AM91	AM93
● APPLE	AP91	AP93
● ASH	CR91	CR93
● BABY BLUE	BB91	BB93
● BONE	BN91	BN93
● BROWN TEA	TE91	TE93
● BUTTER	BT91	BT93
● CELADON	CL91	CL93
● CINNAMON	CM91	CM93
● CITRON	CI91	CI93
● COFFEE	CF91	CF93
● EGG BLUE	EB91	EB93
● EMERALD	EG91	EG93
○ LILY	LY91	LY93
● MARINE BLUE	MR91	MR93
● MELON	ML91	ML93
● MIDNIGHT BLUE	MB91	MB93
● OXBLOOD	OX91	OX93
● PEACOCK	PC91	PC93
● PUMPKIN	PM91	PM93
● RUBY RED	RR91	RR93
● SCHIAPARELLI PINK	SP91	SP93
● SMOKY TAUPE	ST91	ST93
● STEEL BLUE	OB91	OB93
● SUNSET YELLOW	SU91	SU93

MATTE COLORS

● MATTE ASH	MCR91	MCR93
● MATTE CELEDON	MCL91	MCL93
● MATTE COFFEE	MCF91	MCF93
○ MATTE LILY	MLY91	MLY93
● MATTE MIDNIGHT BLUE	MMB91	MMB93
● MATTE SMOKY TAUPE	MST91	MST93
● MATTE STEEL BLUE	MOB91	MOB93

JUNE TABLE LAMP

	BUFF SHADE	OYSTER SHADE
● AMETHYST	AM991	AM993
● APPLE	AP991	AP993
● ASH	CR991	CR993
● BABY BLUE	BB991	BB993
● BONE	BN991	BN993
● BROWN TEA	TE991	TE993
● BUTTER	BT991	BT993
● CELADON	CL991	CL993
● CINNAMON	CM991	CM993
● CITRON	CI991	CI993
● COFFEE	CF991	CF993
● EGG BLUE	EB991	EB993
● EMERALD	EG991	EG993
○ LILY	LY991	LY993
● MARINE BLUE	MR991	MR993
● MELON	ML991	ML993
● MIDNIGHT BLUE	MB991	MB993
● OXBLOOD	OX991	OX993
● PEACOCK	PC991	PC993
● PUMPKIN	PM991	PM993
● RUBY RED	RR991	RR993
● SCHIAPARELLI PINK	SP991	SP993
● SMOKY TAUPE	ST991	ST993
● STEEL BLUE	OB991	OB993
● SUNSET YELLOW	SU991	SU993

MATTE COLORS

● MATTE ASH	MCR98	MCR99
● MATTE CELEDON	MCL98	MCL99
● MATTE MIDNIGHT BLUE	MMB98	MMB99
○ MATTE LILY	MLY98	MLY99
● MATTE MIDNIGHT BLUE	MMB98	MMB99
● MATTE SMOKY TAUPE	MST98	MST99
● MATTE STEEL BLUE	MOB98	MOB99



Mason



MASON TABLE LAMP

● AMETHYST	979
● APPLE	965
● ASH	CR960
● BABY BLUE	966
○ BONE	960
● BROWN TEA	TE960
● BUTTER	970
● CELADON	977
● CINNAMON	974
● CITRON	CI960
● COFFEE	CF960
● EGG BLUE	973
● EMERALD	EG960
○ LILY	962
● MARINE BLUE	976
● MELON	ML960
● MIDNIGHT BLUE	MB960
● OXBLOOD	968
● PEACOCK	964
● PUMPKIN	963
● RUBY RED	RR960
● SCHIAPARELLI PINK	971
● SMOKY TAUPE	972
● STEEL BLUE	OB960
● SUNSET YELLOW	SU960

MATTE COLORS

● MATTE ASH	MCR60
● MATTE CELEDON	MCL60
● MATTE COFFEE	MCF60
○ MATTE LILY	MLY60
● MATTE MIDNIGHT BLUE	MMB60
● MATTE SMOKY TAUPE	MST60
● MATTE STEEL BLUE	MOB60





ORION ACCENT LAMP

● AMETHYST	AM989
● APPLE	AP989
● ASH	CR989
● BABY BLUE	BB989
● BONE	BN989
● BROWN TEA	TE989
● BUTTER	BT989
● CELADON	CL989
● CINNAMON	CM989
● CITRON	CI989
● COFFEE	CF989
● EGG BLUE	EB989
● EMERALD	EG989
○ LILY	LY989
● MARINE BLUE	MR989
● MELON	ML989
● MIDNIGHT BLUE	MB989
● OXBLOOD	OX989
● PEACOCK	PC989
● PUMPKIN	PM989
● RUBY RED	RR989
● SCHIAPARELLI PINK	SP989
● SMOKY TAUPE	ST989
● STEEL BLUE	OB989
● SUNSET YELLOW	SU989

MATTE COLORS

● MATTE ASH	MCR18
● MATTE CELADON	MCL18
● MATTE COFFEE	MCF18
○ MATTE LILY	MLY18
● MATTE MIDNIGHT BLUE	MMB18
● MATTE SMOKY TAUPE	MST18
● MATTE STEEL BLUE	MOB18

ORION TABLE LAMP

● AMETHYST	AM999
● APPLE	AP999
● ASH	CR999
● BABY BLUE	BB999
● BONE	BN999
● BROWN TEA	TE999
● BUTTER	BT999
● CELADON	CL999
● CINNAMON	CM999
● CITRON	CI999
● COFFEE	CF999
● EGG BLUE	EB999
● EMERALD	EG999
○ LILY	LY999
● MARINE BLUE	MR999
● MELON	ML999
● MIDNIGHT BLUE	MB999
● OXBLOOD	OX999
● PEACOCK	PC999
● PUMPKIN	PM999
● RUBY RED	RR999
● SCHIAPARELLI PINK	SP999
● SMOKY TAUPE	ST999
● STEEL BLUE	OB999
● SUNSET YELLOW	SU999

MATTE COLORS

● MATTE ASH	MCR17
● MATTE CELADON	MCL17
● MATTE COFFEE	MCF17
○ MATTE LILY	MLY17
● MATTE MIDNIGHT BLUE	MMB17
● MATTE SMOKY TAUPE	MST17
● MATTE STEEL BLUE	MOB17



Pike



PIKE TABLE LAMP (BRASS BASE)

● AMETHYST	AM994
● APPLE	AP994
● ASH	CR994
● BABY BLUE	BB994
○ BONE	BN994
● BROWN TEA	TE994
● BUTTER	BT994
● CELADON	CL994
● CINNAMON	CM994
● CITRON	CI994
● COFFEE	CF994
● EGG BLUE	EB994
● EMERALD	EG994
○ LILY	LY994
● MARINE BLUE	MR994
● MELON	ML994
● MIDNIGHT BLUE	MB994
● OXBLOOD	OX994
● PEACOCK	PC994
● PUMPKIN	PM994
● RUBY RED	RR994
● SCHIAPARELLI PINK	SP994
● SMOKY TAUPE	ST994
● STEEL BLUE	OB994
● SUNSET YELLOW	SU994

MATTE COLORS

● MATTE ASH	MCR94
● MATTE CELEDON	MCL94
● MATTE COFFEE	MCF94
○ MATTE LILY	MLY94
● MATTE MIDNIGHT BLUE	MMB94
● MATTE SMOKY TAUPE	MST94
● MATTE STEEL BLUE	MOB94

PIKE TABLE LAMP (ACRYLIC BASE)

● AMETHYST	AM996
● APPLE	AP996
● ASH	CR996
● BABY BLUE	BB996
○ BONE	BN996
● BROWN TEA	TE996
● BUTTER	BT996
● CELADON	CL996
● CINNAMON	CM996
● CITRON	CI996
● COFFEE	CF996
● EGG BLUE	EB996
● EMERALD	EG996
○ LILY	LY996
● MARINE BLUE	MR996
● MELON	ML996
● MIDNIGHT BLUE	MB996
● OXBLOOD	OX996
● PEACOCK	PC996
● PUMPKIN	PM996
● RUBY RED	RR996
● SCHIAPARELLI PINK	SP996
● SMOKY TAUPE	ST996
● STEEL BLUE	OB996
● SUNSET YELLOW	SU996

MATTE COLORS

● MATTE ASH	MCR96
● MATTE CELEDON	MCL94
● MATTE COFFEE	MCF94
○ MATTE LILY	MLY94
● MATTE MIDNIGHT BLUE	MMB94
● MATTE SMOKY TAUPE	MST94
● MATTE STEEL BLUE	MOB94



Triple Gourd



LARGE TRIPLE GOURD

- AMETHYST
- APPLE
- ASH
- BABY BLUE
- BONE
- BROWN TEA
- BUTTER
- CELADON
- CINNAMON
- CITRON
- COFFEE
- EGG BLUE
- EMERALD
- LILY
- MARINE BLUE
- MELON
- MIDNIGHT BLUE
- OXBLOOD
- PEACOCK
- PUMPKIN
- RUBY RED
- SCHIAPARELLI PINK
- SMOKY TAUPE
- STEEL BLUE
- SUNSET YELLOW

BRASS BASE

- 381X
- 313X
- CR40X
- 321X
- 324X
- TE40X
- 317X
- 369X
- 325X
- CI40X
- CF40X
- 322X
- EG40X
- 311X
- 366X
- ML40X
- MB40X
- 315X
- 323X
- 312X
- RR40X
- 318X
- 319X
- OB40X
- SU40X

BRONZE BASE

- 382X
- 333X
- CR41X
- 341X
- 344X
- TE41X
- 337X
- 370X
- 345X
- CI41X
- CF41X
- EG41X
- 331X
- ML41X
- MB41X
- 335X
- 343X
- 332X
- RR41X
- 338X
- 339X
- OB41X
- SU41X

ANT. SILVER BASE

- 383X
- 353X
- CR42X
- 361X
- 364X
- TE42X
- 357X
- 371X
- 365X
- CI42X
- CF42X
- 362X
- EG42X
- 351X
- 368X
- ML42X
- MB42X
- 363X
- 352X
- RR42X
- 358X
- 359X
- OB42X
- SU42X

LUCITE BASE

- A383X
- A353X
- CR43X
- A361X
- A364X
- TE43X
- A357X
- A371X
- A365X
- CI43X
- CF43X
- A362X
- EG43X
- A351X
- A368X
- ML43X
- MB43X
- A355X
- A363X
- A352X
- RR43X
- A358X
- A359X
- OB43X
- SU43X

MATTE COLORS

- MATTE ASH
- MATTE CELEDON
- MATTE COFFEE
- MATTE LILY
- MATTE MIDNIGHT BLUE
- MATTE SMOKY TAUPE
- MATTE STEEL BLUE

- MCR40
- MCL40
- MCF40
- MLY40
- MMB40
- MST40
- MOB40

- MCR41
- MCL41
- MCF41
- MLY41
- MMB41
- MST41
- MOB41

- MCR42
- MCL42
- MCF42
- MLY42
- MMB42
- MST42
- MOB42

- MCR43
- MCL43
- MCF43
- MLY43
- MMB43
- MST43
- MOB43



Triple Gourd



SMALL TRIPLE GOURD

- AMETHYST
- APPLE
- ASH
- BABY BLUE
- BONE
- BROWN TEA
- BUTTER
- CELADON
- CINNAMON
- CITRON
- COFFEE
- EGG BLUE
- EMERALD
- LILY
- MARINE BLUE
- MELON
- MIDNIGHT BLUE
- OXBLOOD
- PEACOCK
- PUMPKIN
- RUBY RED
- SCHIAPARELLI PINK
- SMOKY TAUPE
- STEEL BLUE
- SUNSET YELLOW

BRASS BASE

- 378X
- 243X
- CR30X
- 251X
- 254X
- TE30X
- 247X
- 256X
- 255X
- CI30X
- CF30X
- 252X
- EG30X
- 241X
- 296X
- ML30X
- MB30X
- 245X
- 253X
- 242X
- RR30X
- 248X
- 249X
- OB30X
- SU30X

BRONZE BASE

- 379X
- 263X
- CR31X
- 271X
- 274X
- TE31X
- 267X
- 257X
- 275X
- CI31X
- CF31X
-
- EG31X
- 261X
-
- ML31X
- MB31X
- 265X
- 273X
- 262X
- RR31X
- 268X
- 269X
- OB31X
- SU31X

ANT. SILVER BASE

- 380X
- 283X
- CR32X
- 291X
- 294X
- TE32X
- 287X
- 258X
- 295X
- CI32X
- CF32X
- 292X
- EG32X
- 281X
- 298X
- ML32X
- MB32X
-
- 293X
- 282X
- RR32X
- 288X
- 289X
- OB32X
- SU32X

LUCITE BASE

- A380X
- A283X
- CR33X
- A291X
- A294X
- TE33X
- A287X
- A258X
- A295X
- CI33X
- CF33X
- A292X
- EG33X
- A281X
- A298X
- ML33X
- MB33X
- A285X
- A293X
- A282X
- RR33X
- A288X
- A289X
- OB33X
- SU33X

MATTE COLORS

- MATTE ASH
- MATTE CELEDON
- MATTE COFFEE
- MATTE LILY
- MATTE MIDNIGHT BLUE
- MATTE SMOKY TAUPE
- MATTE STEEL BLUE

- MCR30
- MCL30
- MCF30
- MLY30
- MMB30
- MST30
- MOB30

- MCR31
- MCL31
- MCF31
- MLY31
- MMB31
- MST31
- MOB31

- MCR32
- MCL32
- MCF32
- MLY32
- MMB32
- MST32
- MOB32

- MCR33
- MCL33
- MCF33
- MLY33
- MMB33
- MST33
- MOB33





VICTOR TABLE LAMP

- | | |
|---------------------|------|
| ● AMETHYST | AM03 |
| ● APPLE | AP03 |
| ● ASH | CR03 |
| ● BABY BLUE | BB03 |
| ● BONE | BN03 |
| ● BROWN TEA | TE03 |
| ● BUTTER | BT03 |
| ● CELADON | CL03 |
| ● CINNAMON | CM03 |
| ● CITRON | CI03 |
| ● COFFEE | CF03 |
| ● EGG BLUE | EB03 |
| ● EMERALD | EG03 |
| ○ LILY | LY03 |
| ● MARINE BLUE | MR03 |
| ● MELON | ML03 |
| ● MIDNIGHT BLUE | MB03 |
| ● OXBLOOD | OX03 |
| ● PEACOCK | PC03 |
| ● PUMPKIN | PM03 |
| ● RUBY RED | RR03 |
| ● SCHIAPARELLI PINK | SP03 |
| ● SMOKY TAUPE | ST03 |
| ● STEEL BLUE | OB03 |
| ● SUNSET YELLOW | SU03 |



MATTE COLORS

- | | |
|-----------------------|-------|
| ● MATTE ASH | MCRO3 |
| ● MATTE CELEDON | MCL03 |
| ● MATTE COFFEE | MCF03 |
| ○ MATTE LILY | MLY03 |
| ● MATTE MIDNIGHT BLUE | MMB03 |
| ● MATTE SMOKY TAUPE | MST03 |
| ● MATTE STEEL BLUE | MOB03 |



Atlas



- MATTE ASH
- MATTE DARK COAL
- MATTE DOVE
- MATTE LILY
- MATTE MIDNIGHT BLUE
- MATTE SKY BLUE
- MATTE WOODROSE

BRASS BASE

MCR21
MDC21
MDV21
MLY21
MMB21
MSB21
MWR21

BRONZE BASE

MCR22
MDC22
MDV22
MLY22
MMB22
MSB22
MWR22

ANTIQUE NICKEL BASE

MCR20
MDC20
MDV20
MLY20
MMB20
MSB20
MWR20

Hadrian



- MATTE ASH
- MATTE DARK COAL
- MATTE DOVE
- MATTE LILY
- MATTE MIDNIGHT BLUE
- MATTE SKY BLUE
- MATTE WOODROSE

BRASS BASE

MCR27
MDC27
MDV27
MLY27
MMB27
MSB27
MWR27

BRONZE BASE

MCR28
MDC28
MDV28
MLY28
MMB28
MSB28
MWR28

ANTIQUE NICKEL BASE

MCR26
MDC26
MDV26
MLY26
MMB26
MSB26
MWR26

Nolan



- MATTE ASH
- MATTE DARK COAL
- MATTE DOVE
- MATTE LILY
- MATTE MIDNIGHT BLUE
- MATTE SKY BLUE
- MATTE WOODROSE

BRASS BASE

MCR24
MDC24
MDV24
MLY24
MMB24
MSB24
MWR24

BRONZE BASE

MCR25
MDC25
MDV25
MLY25
MMB25
MSB25
MWR25

ANTIQUE NICKEL BASE

MCR23
MDC23
MDV23
MLY23
MMB23
MSB23
MWR23

Terms and Conditions

Our acceptance of any order is made conditional on the buyer's agreement to the terms and conditions as stated herein.

Terms

- Proforma invoices are available. The order will be entered and scheduled for production upon receipt of funds.
- Open account terms are net 30 days of invoice (no cash anticipation discounts).
- Slow payments will delay shipments.
- We do not ship C.O.D. under any circumstances.
- Accounts must maintain a minimum annual volume to remain an active account and receive wholesale pricing.

Ordering

- A minimum opening order is required to establish an account. Please check with your local Sale Rep.
- Clearly mark "confirmation do not duplicate" on orders previously called or faxed to prevent duplication.
- Unless otherwise stated, all back orders will be cancelled.
- Custom items meeting minimums will require a 50% deposit and balance before delivery.
- Orders are entered based on the style number on the order, not the description.

Quick Ship

- Quick ship items are shipped within 2-3 business days after the order date (based upon stock availability). Check with your local Sales Rep or www.robtabbey.com for shipping lead times on each style.
- Quick Ship items are designated on the Robert Abbey price list.
- Cancellations of Quick Ship orders must be made within 24 hours of order placement.
- Non-Quick Ship orders usually ship within 1-2 weeks after order date (based upon stock availability).

Rush Orders

- We offer an expedited service on small quantities (2 pieces maximum) for rush orders on Non-Quick Ship items.
- If the components are available, we can ship the items within 5-7 business days, with payment of a \$50 expedited production fee for each 2 pieces. This service applies to small rush orders only.

Shipping & Handling

- **No Drop Ship Fee.**
- All shipments are F.O.B. Factory Hickory, North Carolina.
- All freight is sent freight collect, unless otherwise negotiated.
- Seller assumes no responsibility for damage in transit.
- Most UPS and FedEx Ground shipments are sent prepaid and added to the customer's invoice. (There may be exceptions.)
- Robert Abbey will ship best and cheapest unless otherwise directed.
- Note that other fees may apply to the base rate such as Inside Deliveries, Residential Delivery, and Liftgate service.

Cancellations

- Orders in production cannot be canceled.
- Contact your local Sales Rep or customer service at Robert Abbey for all cancellations.

Deductions

- No deductions allowed without prior authorization from Robert Abbey.

Exchanges & Returns

- Robert Abbey requires all products to be returned to us within 30 days within the original packaging.
- All returns must have a call tag issued by Robert Abbey.
- Initial shipping charges are not refundable.
- Product deemed not defective are subject to a 20% restocking fee which will be applied as a credit to the account.
- Any product returned to Robert Abbey without prior authorization will receive a 30% restocking fee upon receipt.

Warranty & Damages

- All Damages must be reported to Robert Abbey within 30 days of delivery to file a claim. No claims will be accepted after 30 days.
- Robert Abbey offers a 365-day limited warranty from date of purchase against defects in materials, workmanship, wiring, and internal rewiring. Defects due to improper care, handling, maintenance, and improper assembly or installation will void any warranty claims.



FACTORY & CORPORATE OFFICE

3166 Main Avenue SE, Hickory, NC 28601
Phone: 828.322.3480 Fax: 828.328.1037

www.robertabbey.com

PERMANENT SHOWROOM

Dallas, TX WTC 305-1