





« Love is a word of light  
written by a hand of  
light  
upon a page of light »

Kahlil Gibran, Lebanese poet

THE  
**STUDIO**

---

Sensitive and emotional manufactures.

**HIND RABII IS DEVOTED  
TO SHEDDING LIGHT ON  
HIS LETTERS OF EMOTION.**



Since 1997, the designers Hind Rabii and Michel Orban both industrial engineers have a common passion and love for creation, design and innovation.

We expect lights to shed light, to shine, to create shadows. To do this, the poetry of materials, glass, wood, gold and silver leaf, colours used by HIND RABII, positively alter the realities for playing the emotions card without indifference.

Because here is the poetic message of filters, colours, blended reflections, transparency that appears to make every HIND RABII model appeal to the desire of love and of light.

And today we still have, a need for these words cast on a page of white vellum.

Like you, we imagine that the HIND RABII brand is and will be synonymous with all these terms that are only language.

This language which skillfully builds itself in front of the manufactures that are glass blowing, confection of lampshades, wood, aluminium and steel work. All these trades that HIND RABII manages to show only the essentials.

As the Lebanese poet Kahlil Gibran writes, the writing of a hand of light, on a page of light is the vision of light that we offer.



A HANDCRAFT WORK MADE  
BY ITALIAN ARTISANS WITH  
ANCESTRAL KNOWLEDGE OF THE  
MATERIAL AND THE METHOD.



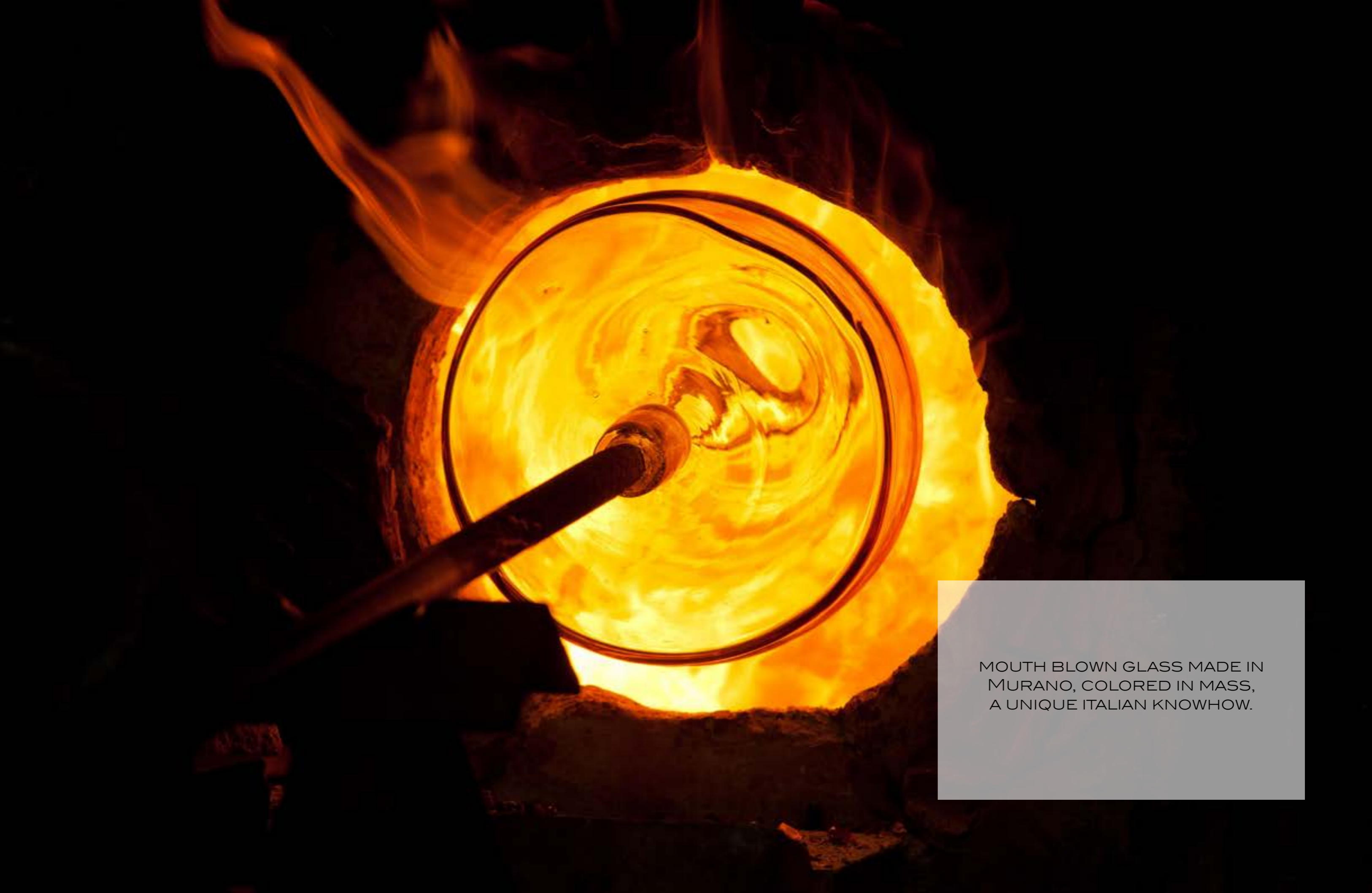

MOUTH BLOWN GLASS MADE IN  
MURANO, COLORED IN MASS,  
A UNIQUE ITALIAN KNOWHOW.

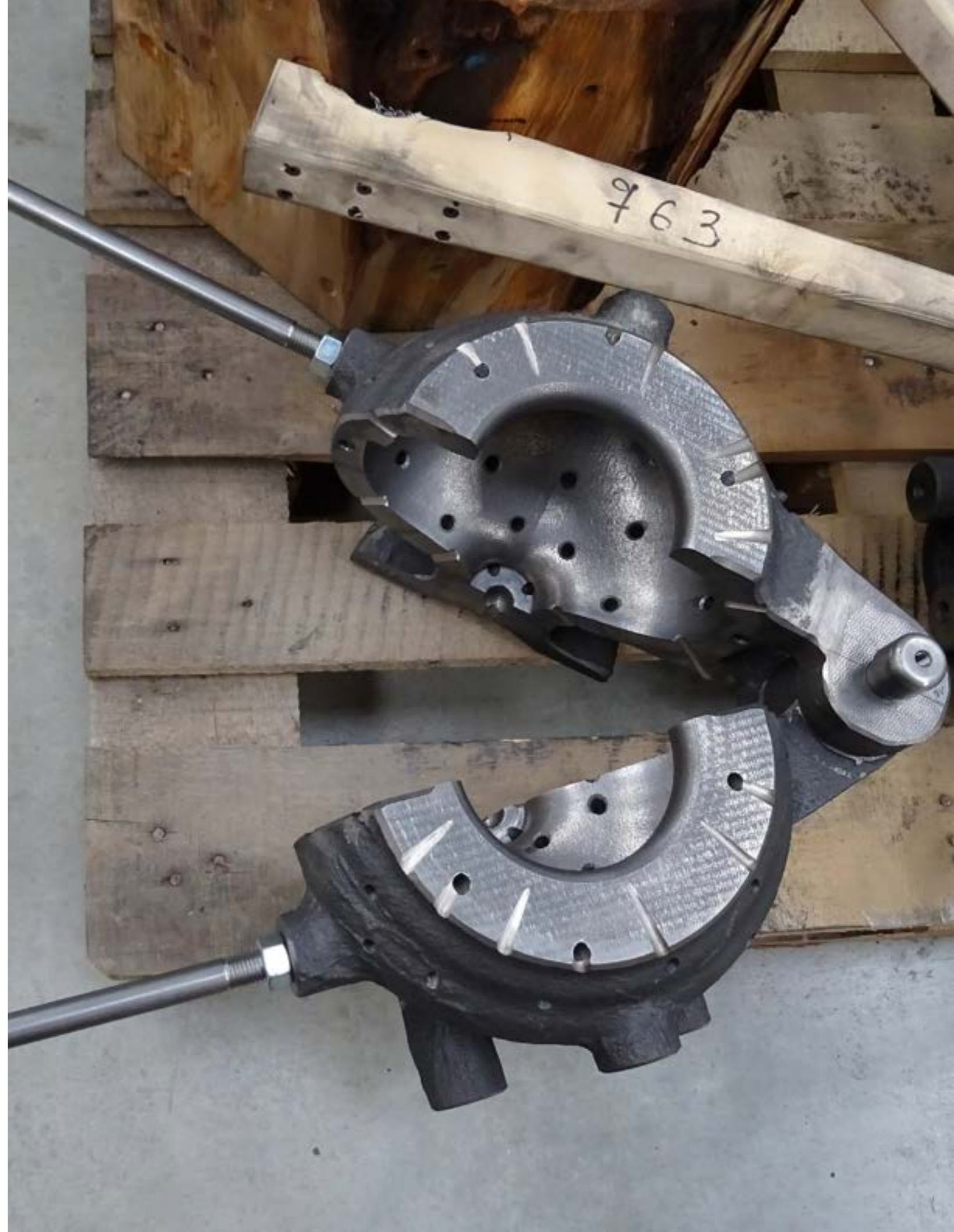



01-  
**INFINITY**  
by Chiaramonte-Marin Studio  
/ 2021



Product p.28  
Technicals p.37

02-  
**HALF &  
HALF**  
by Alain Gilles / 2021



Product p.40  
Technicals p.47-53

03-  
**OASI**  
by Chiaramonte-Marin Studio  
/ 2021

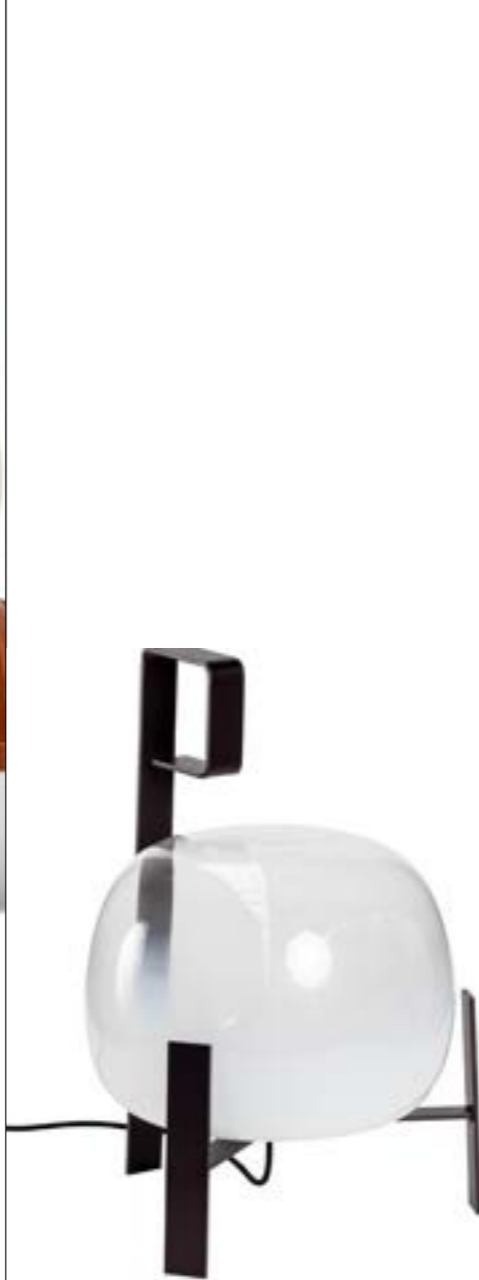

Product p.56  
Technicals p.63

04-  
**TREZERO**  
by Alberto Nason / 2022



Product p.65  
Technicals p.69

05-  
**T-COTTA**  
by Chiaramonte-Marin Studio  
/ 2018



Product p.71  
Technicals p.77-81-89

06-  
**MERIDIANA**  
by Chiaramonte-Marin Studio  
/ 2018



Product p.91  
Technicals p.95-103

07-

## FICO

by Hind Rabii / 2018



Product p.104  
Technicals p.111

08-

## DISCA

by Alberto Nason / 2017



Product p.113  
Technicals p.121

09-

## YA-YA

by Hind Rabii / 2017



Product p.123  
Technicals p.129

10-

## ICE ABSOLUT

by Hind Rabii / 2015

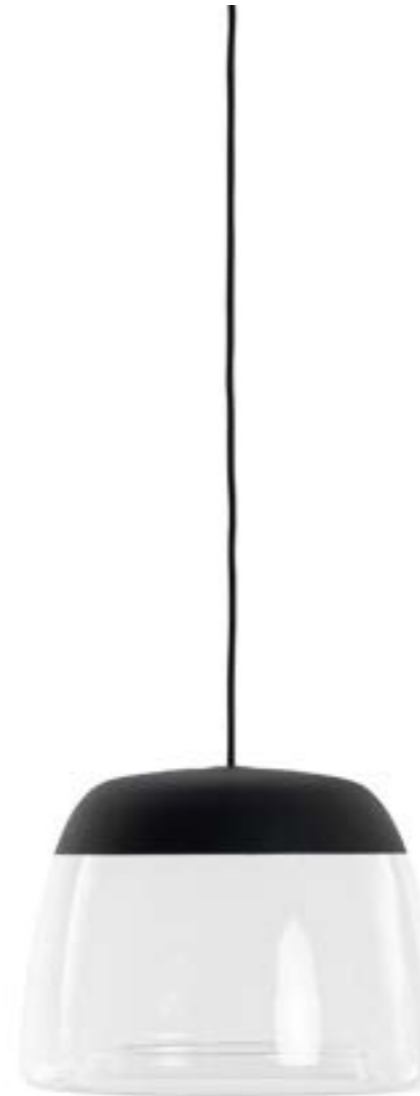

Product p.131  
Technicals p.137

11-

## ESPRIT YA-YA

by Hind Rabii / 2017



Product p.138  
Technicals p.143

12-

## ANNA BELLE

by Hind Rabii / 2017



Product p.145  
Technicals p.149

13-  
**NEWELS**  
by Hind Rabii / 2014



Product p.151  
Technicals p.155

14-  
**3X3X3**  
by Hind Rabii / 2014



Product p.157  
Technicals p.161-165

15-  
**TENUE DE  
SOIRÉE**  
by Hind Rabii / 2015



Product p.167  
Technicals p.173

17-  
**OND'A**  
by Hind Rabii / 2018

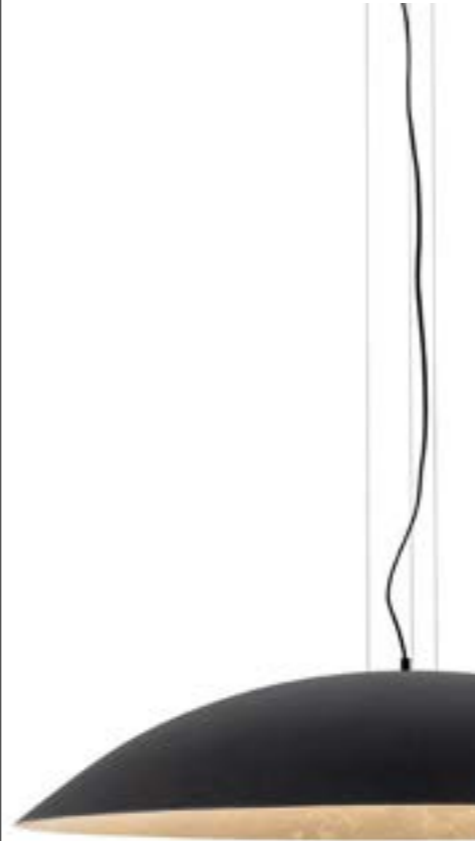

Product p.175  
Technicals p.179

16-  
**ICE**  
by Hind Rabii / 2017



Product p.181  
Technicals p.185

18-  
**REFLECTORS**  
by Hind Rabii / 2014



Product p.191  
Technicals p.197-201

19-

# LET ME READ

by Hind Rabii / 2022



Product p.203  
Technicals p.205

## BESPOKE

As manufacturers, most of our designs could be customised for special projects. Any cable height, colors, finishes or even dimensions may be on measure.

Our design office will help architects and interior designers for any bespoke project. We developed also a complete range of hanging solutions to fit into projects with special specifications. Any project could be studied by us to suggest the best we can. We developed canopies for single hanging lamps but also for small or even big combinations.

For any special project: [office@hindrabii.com](mailto:office@hindrabii.com)  
From Belgium to the world.

### LEXICON :

**Sizes** : all dimensions on technical drawings are in mm

**K** : Kelvin (light temperature)

**lm** : lumens (luminous flow)

**Phase-cut dimming** : dimmable with a phase-cut dimmer (standard on all products)

### GOOD TO KNOW ABOUT DIMMING :

#### PHASE-CUT DIMMING.

All our products are delivered and tested with analog phase-cut dimming capability.

#### DALI

For most situations phase-cut dimming is the right way but for new projects for your modern home or for hospitality projects you may need the digital standard DALI. We also provide on request led drivers for DALI system, contact us !

#### CASAMBI

Use your phone as a switch or dimmer.

We provide the good solution with the Casambi system. Ask for it !

THE  
**COLLECTIONS**

---

The poetry of materials



Create an object that has no limits, that cannot have a conclusion.

01

# INFINITY

Design by Chiaramonte-Marin / 2021

Create an object that has no limits, that cannot have a conclusion because precisely, without end.  
Infinity, is definitely the contemporary and timeless tripod light, as an object of our life that has no need to be reinvented.





### THE DESIGNERS

Infinity, as soon as it was launched, receives design awards from Italy and Germany . Here a presentation of the designers who made this particular and timeless floor lamp. A spirit and inspiration from the past for a long future.



**CHIARAMONTE ALFREDO & MARCO MARIN DESIGN**

The passion for objects meant as industrial products is the glue of the professional partnership between Alfredo Chiaramonte and Marco Marin, promoting partners of the homonymous Designstudio. The different activities experienced through the years (interiors, graphics, industrial and lighting design) brought to a mixed knowledge, contaminated by ideas developed in many fields.

Alfredo Chiaramonte was born in Bologna and studied at the Faculty of Architecture of Venice. Marco Marin was born in Venice and graduated at the Academy of Fine Arts specializing in industrial design.

They worked together with well known furniture and lighting companies. They taught at the European Center for preservation of the architectural heritage in Venice.

Through the years they received many recognitions and some of their works have been exposed in the permanent collections of International Museums, like Museo Correr in Venice, Beaubourg in Paris, Design Museum of Calenzano Anna Querci Foundation) Moma in San Francisco and the Venice Biennale when they worked with Yoko Ono.





Infinity galvanic black  
Infinity bronze





Infinity Galvanic black

# INFINITY

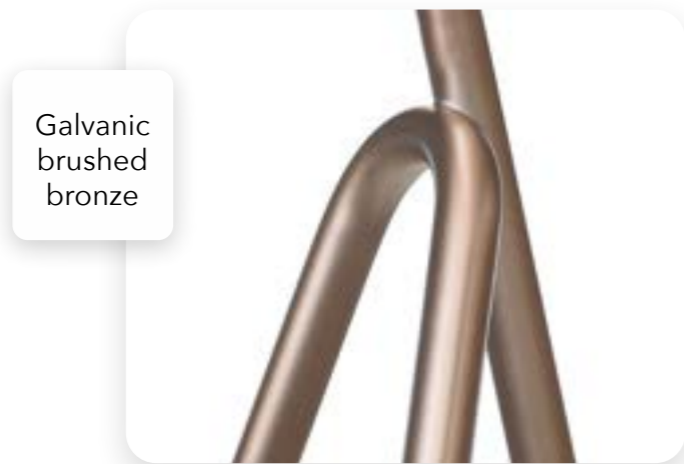
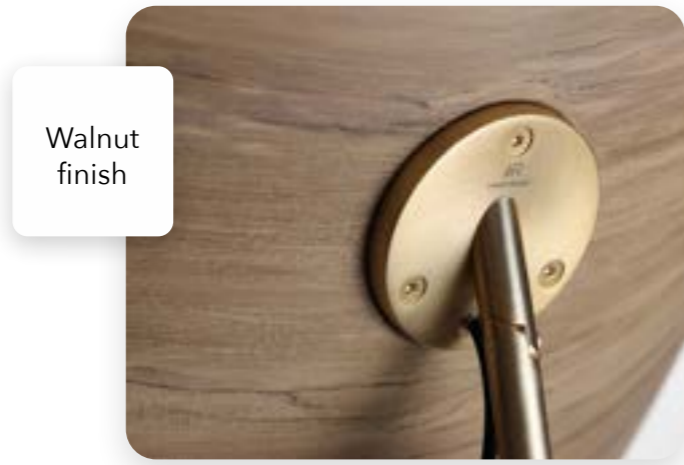

# INFINITY

## LAMPSHADES



Matt black

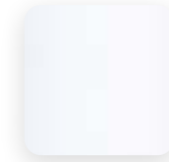

Matt white

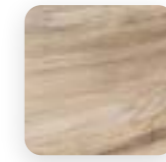

Walnut

## STRUCTURE

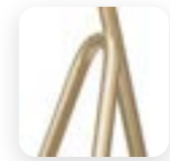

Brushed gold

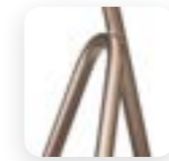

Brushed bronze

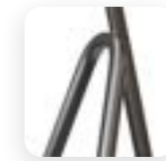

Brushed black



## TECHNICAL

**-INFINITY**  
IP20 led COB 16w  
2700K 2600 lm  
Cable plug with dimmer switch.



# HALF & HALF

Design Alain Gilles / 2021

The perception of a material would almost always appear different as the daylight changes with time, or when the light is lit in the evening.

02

# HALF&HALF

Design by Alain Gilles / 2021

Create an object that has no limits, that cannot have a conclusion because precisely, without end. Infinity, is definitely the contemporary and timeless tripod light, as an object of our life that has no need to be reinvented.





Half&Half L Toscan  
Half&Half S Smooth



# HALF&HALF

Glossy finish



Smooth off white



# HALF&HALF

## CERAMIC



Caviar



Green



Smooth



Toscan

## GLASS



Opal white

## TECHNICAL

**-HALF&HALF S**  
IP20 G9 led bulb 2 x 5w  
2700K 700 lm  
Phase-cut dimming

**-HALF&HALF L**  
IP20 G9 led bulb 3 x 5w  
2700K 1050 lm  
Phase-cut dimming

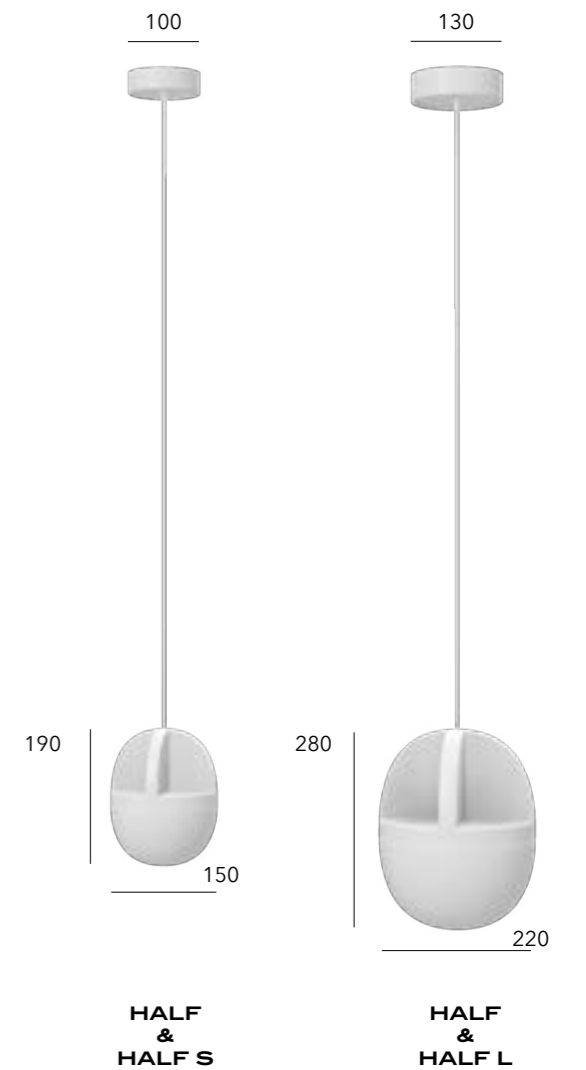







Half&Half wall  
Smooth-Green-Toscan



# HALF&HALF WALL

Glossy finish



Process start



# HALF&HALF WALL

## CERAMIC



Caviar



Green



Smooth



Toscan

## GLASS



Opal white

## TECHNICAL

**-HALF&HALF WALL S**  
IP20 G9 led bulb 2 x 5w  
2700K 700 lm  
Phase-cut dimming.

800



445

HALF & HALF WALL



Oasi...fantastic animals transformed into bright objects created to stand under the sky.

03

# OASI

Design by Chiaramonte-Marin / 2021

Fantastic animals transformed into bright objects created to stand under the sky.

Oasi comes with a base in stainless steel, finished with fine outdoor powder and mouth Italian blown glass.

Combination of colors, inspired by the earth as this Ourika color, name of red valley in south Marrakech.







Oasi S Uva nera-Sfumato

# OASI

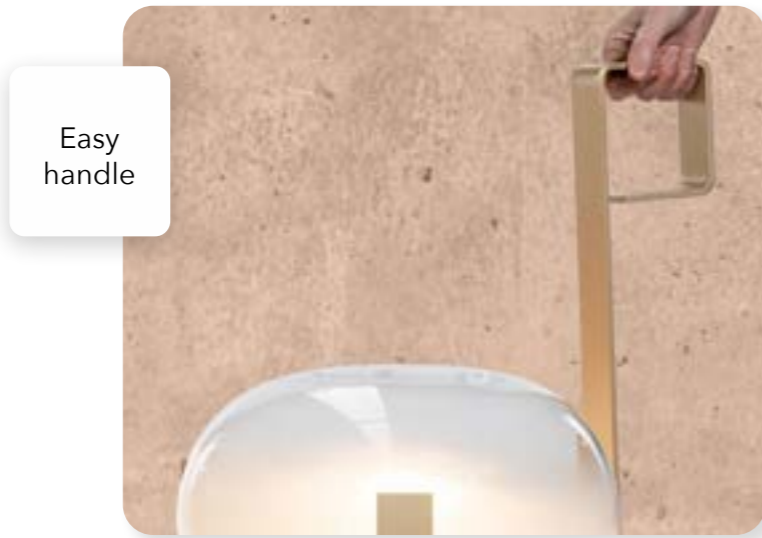

Easy handle

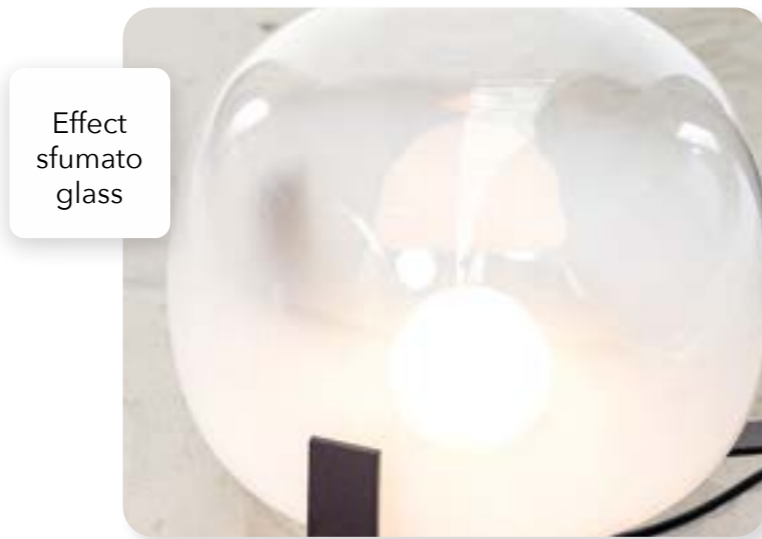

Effect sfumato glass

## STRUCTURE



Champagne



Rosa

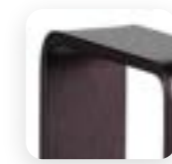

Uva nera

## GLASS



Sfumato



Fumé

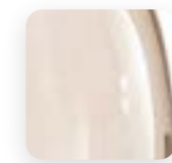

Peach

## TECHNICAL

- OASI S  
IP44 G9 led bulb 2700K 400 lm
- OASI MA  
IP44 G9 led bulb 2700K 400 lm
- OASI MB  
IP44 G9 led bulb 2700K 400 lm
- OASI L  
IP44 G9 led bulb 2700K 400 lm

Indoor version (IP20) : cable plug with dimmer switch.

# OASI

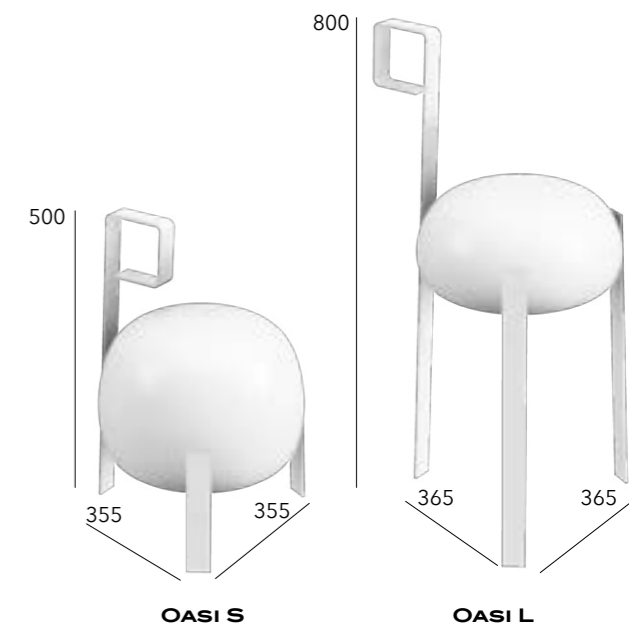
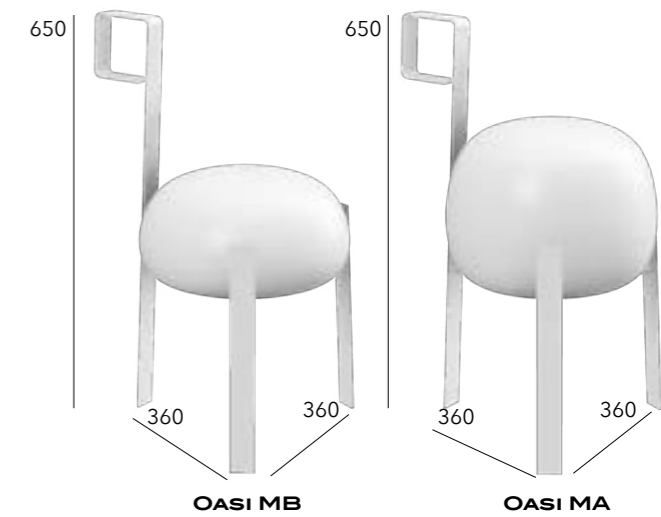



O4

# TREZERO

Design by Alberto Nason / 2022

Trezero is the last design from the Italian designer Alberto Nason. Reinterpretation of classical -Lustre- with 3 big glass discs made in Italy, the special technic of the glass is called Vetro Lastra. Back light going on the glasses, makes unique atmosphere.





# TREZERO

Handmade  
glass



Back light  
detail



## STRUCTURE



Matt black

## GLASS



Opal white

## TECHNICAL

**-TREZERO**  
Led module 3x7w 2700K 3500 lm  
Phase-cut dimming.

# TREZERO



TREZERO

05

# T-COTTA

Design by Chiaramonte-Marin / 2018

Created from the desire to create an object of fluid, curved forms, T-COTTA is the fruit of the union of materials, both of which come from earth, both are worked by man and both forged by heat.





TC4 Terracotta-opal white  
TC1 Terracotta-opal white



TC1 Grey-cristal  
TC3 Grey-cristal



TC1 Smooth-opal white  
TC2 Smooth-opal white



TC4 Black diamond-crystal  
TC1 & TC2 Black diamond-crystal

# T-COTTA



# T-COTTA

## CERAMIC

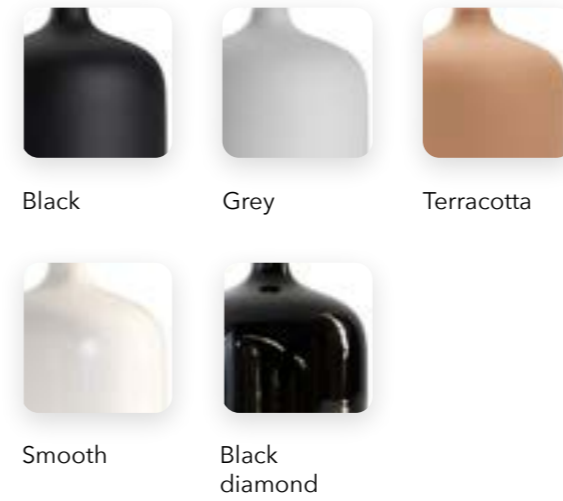

## GLASS



## TECHNICAL

- T-COTTA TC1**  
IP20 module led 8W 2700K 1200 lm
- T-COTTA TC2**  
IP20 module led 8W 2700K 1200 lm
- T-COTTA TC3**  
IP20 module led 8W 2700K 1200 lm
- T-COTTA TC4**  
IP20 led module 23W 2700K 3000 lm

Phase-cut dimming.

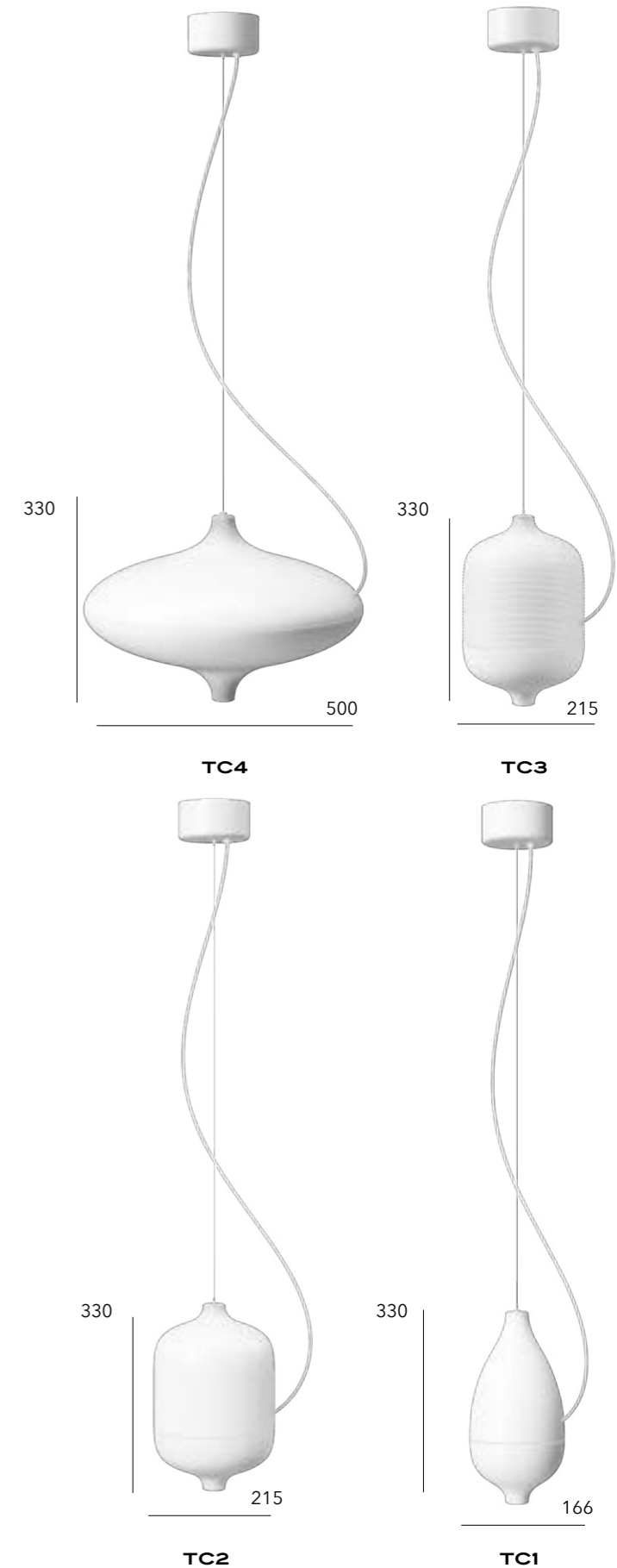

T-Cotta wall comes naturally in this collection as a wall or ceiling lamp, the source is invisible, discreet but efficient. the front glass comes in different finishes but always with this ceramic precious structure.





# T-COTTA WALL



# T-COTTA WALL

## GLASS FINISH

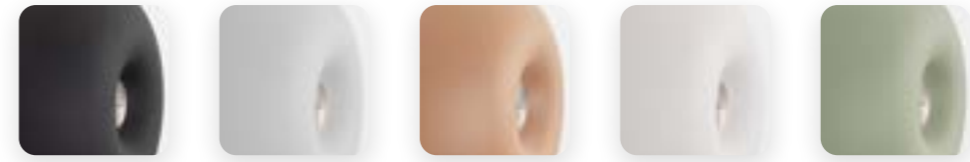

Matt black    Grey    Terracotta    Pink    Green



All opal white



Smooth



Black diamond

## TECHNICAL

**T-COTTA WALL**  
IP20 Led Module 8W 2700K 1000 lm  
Phase-cut dimming.

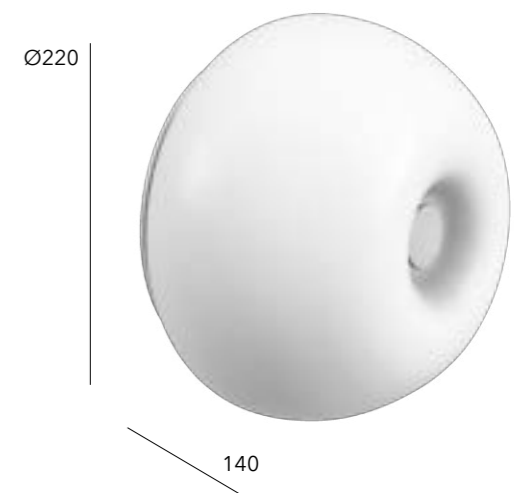

**T-COTTA WALL**







# T-COTTA THE LAMP

Black  
chrome on  
solid brass



Smooth  
pink finish



# T-COTTA THE LAMP

## GLASS FINISH

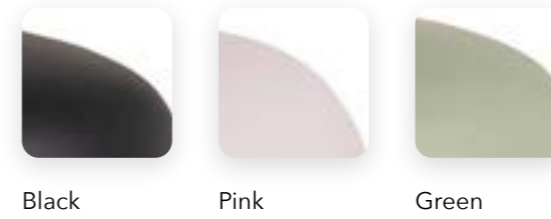

Black

Pink

Green

## MARBLE

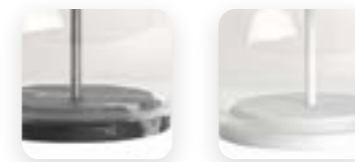

Nero  
marquina

White  
carrara

## TECHNICAL

- T-COTTA TS**  
Led module 12w 2700K 1500 lm
- T-COTTA TM**  
Led module 12w 2700K 1500 lm
- T-COTTA FL**  
Led module 12w 2700K 1500 lm

Cable plug with dimmer switch.

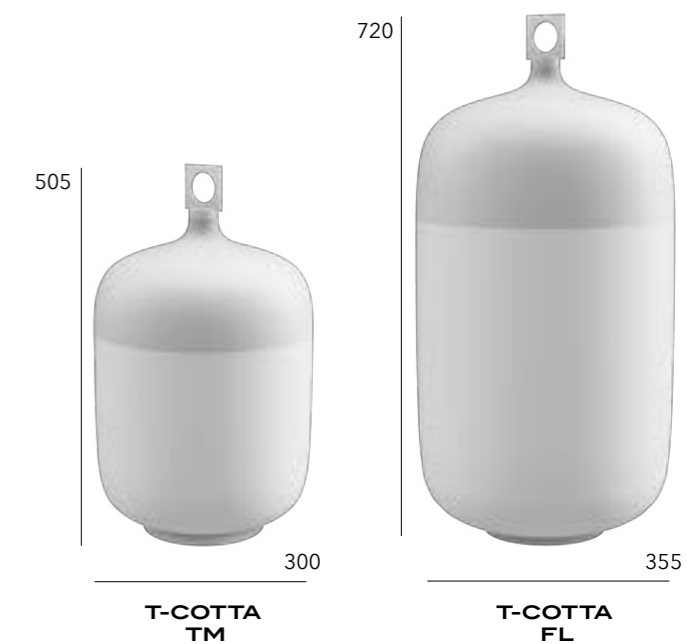

06

# MERIDIANA

Design by Chiaramonte-Marin / 2018

Meridiana: this is not a sundial.  
The process in fact is inverse: here the light is not the means, but the purpose, a great disk like the sun and hidden behind a big clock hand or what it seems like, a gentle and smooth not blinding light.





# MERIDIANA

Special structure



Shape detail



# MERIDIANA

## SHADE



Matt white

## DIFFUSOR



White marble



Wengé oak

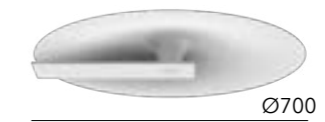

Ø700

MERIDIANA CEILING S



Ø700

MERIDIANA S

## TECHNICAL

### -MERIDIANA S & MERIDIANA S CEILING

IP20 led module 9w 2700K 1500 lm

### -MERIDIANA L & MERIDIANA L CEILING

IP20 led module 45w 2700K 5000 lm

Phase-cut dimming.



Ø1100

MERIDIANA CEILING L



Ø1100

MERIDIANA L







Meridiana ceiling L



Meridiana floor

# MERIDIANA

Special structure



Back detail Meridiana floor



# MERIDIANA

SHADE



Matt white

DIFFUSOR



White marble



Wengé oak

TECHNICAL

**-MERIDIANA WALL- L**  
IP20 led module 35w 2700K 4000 lm

**-MERIDIANA FLOOR**  
IP20 led module 35w 2700K 4000 lm

Phase-cut dimming.



Ø700

**MERIDIANA WALL  
S**

Ø1100



650

**MERIDIANA FLOOR**

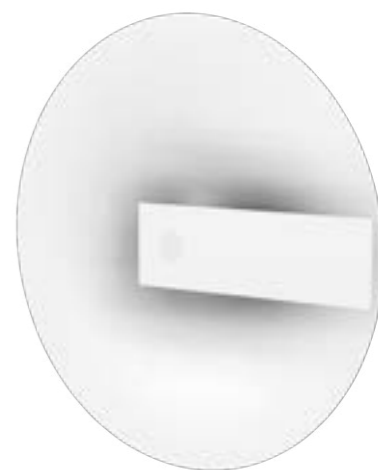

Ø1100

**MERIDIANA WALL**

07

# FICO

Design by Chiaramonte Marin Studio / 2018

Like the fruit of the same name (FIG in Italian), which conceals succulent pulp beneath a thick skin, here the light is protected by a shell of ceramic hanging from a tape as if from the branch of its tree. It comes in three different shapes.



Fico 1 White  
Fico 2 White  
Fico 3 White



Fico 1 Black





# FICO

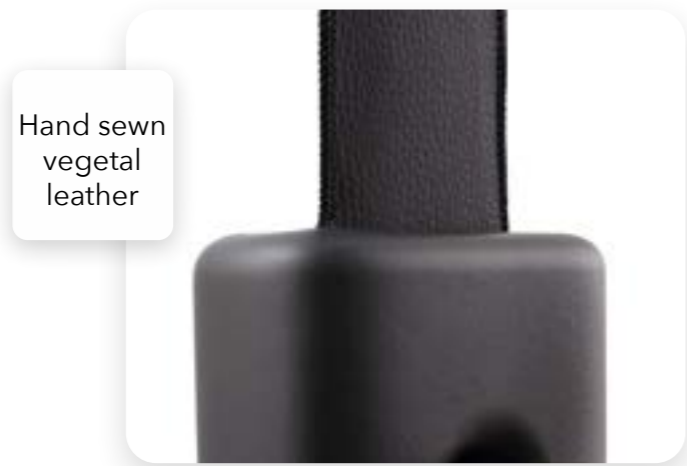

# FICO

## CERAMIC

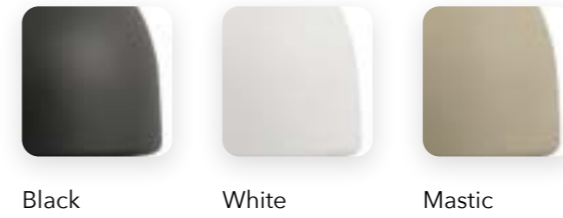

Black

White

Mastic

## BELT FINISHES



White  
Leather

Black  
Leather

Cognac  
Leather

Velvet  
Black

Velvet  
Green

Velvet  
Pisé

## TECHNICAL

- FICO 1 - FICO 2 - FICO 3  
IP20 E27 led bulb 13w 2700K 1100 lm  
Phase-cut dimming.

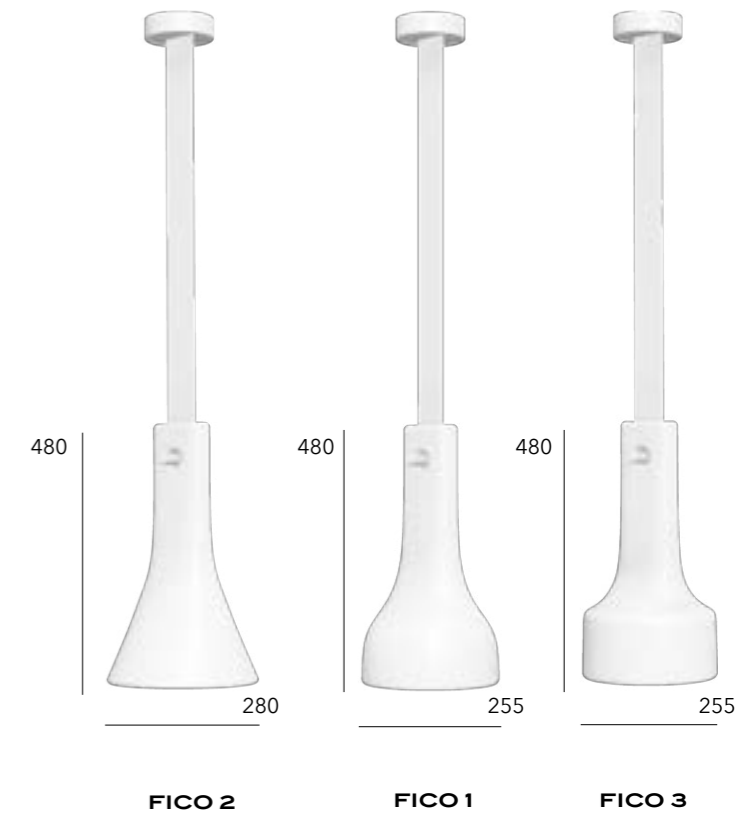



08

# DISCA

Design by Alberto Nason / 2017

Sometimes a luminous apparition seems to come from elsewhere.  
In green, transparent white, milky or transparent lava glass, DISCA expresses itself fully in any defined or virtual place.

Its flashes of light carry its shapes off to infinity, as they spin on themselves in a Venetian vortex or a Viennese Waltz.





Disca S Cristal-fumé blue



Disca S Opal white-white



Disca T Amber-Wengé

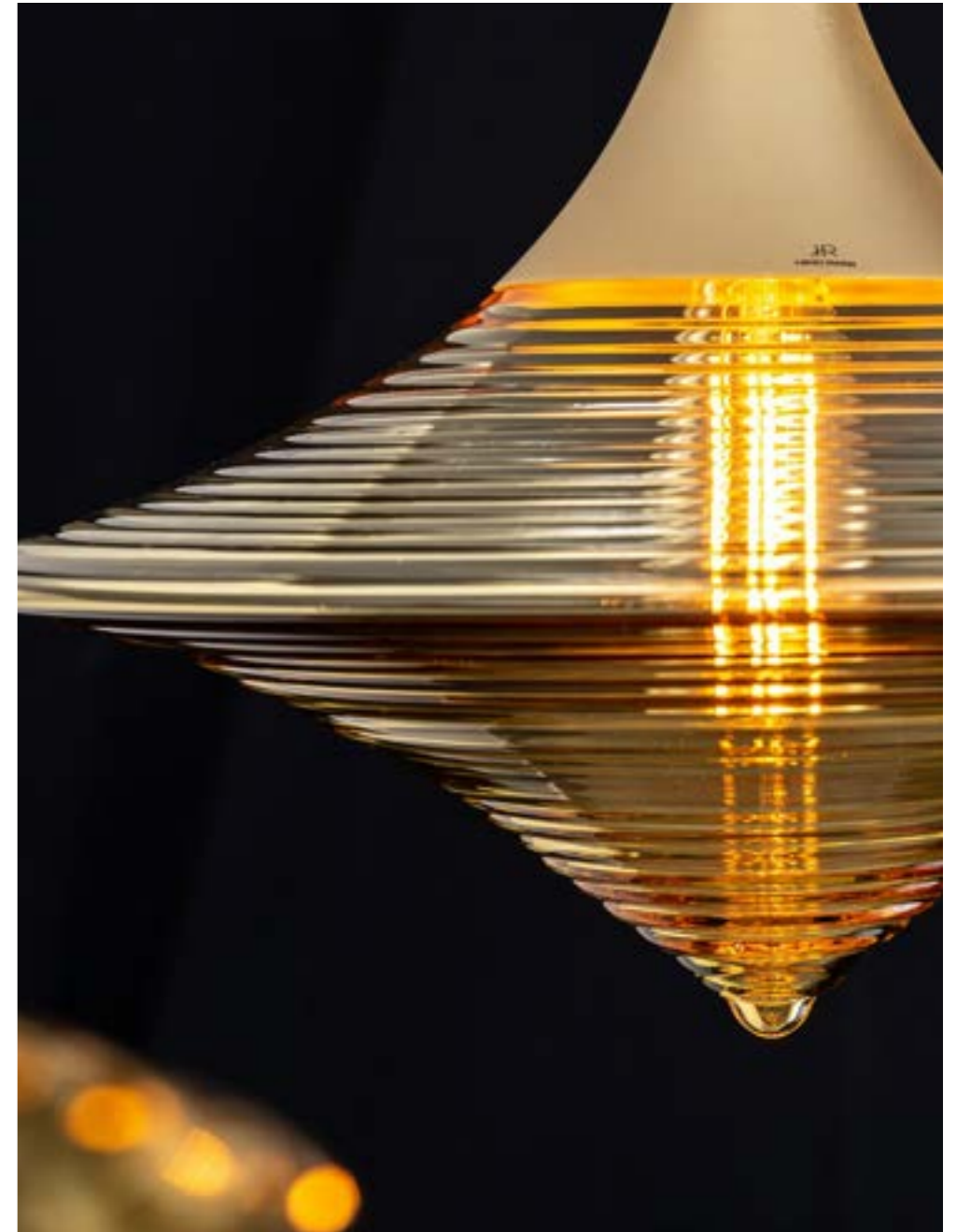



Disca green makes light integrate nature, playing with reflection on this special mouth blown glass.

# DISCA

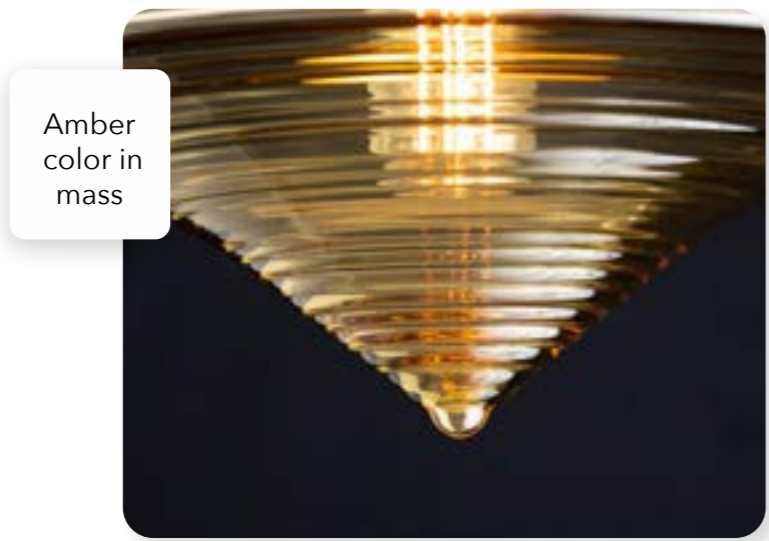

Amber color in mass

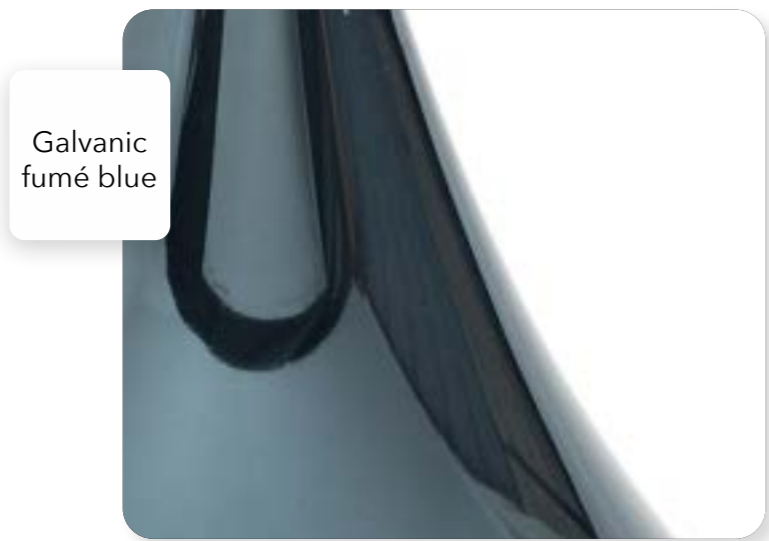

Galvanic fumé blue

# DISCA

## GLASS FINISH

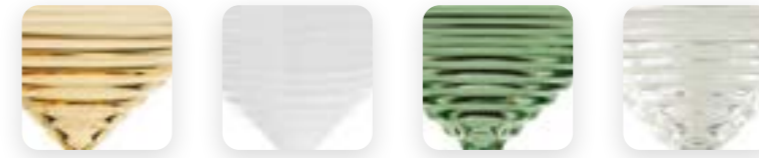

Amber

Opal white

Green

Cristal

## CAP

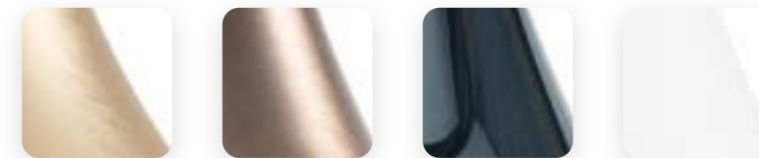

Brushed gold

Brushed bronze

Fumé blue

Matt white

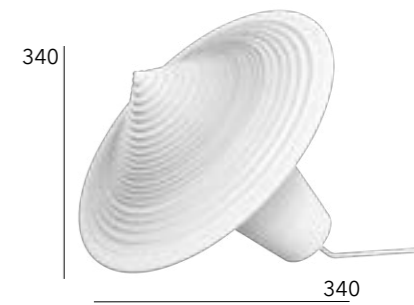

DISCA T

## TECHNICAL

- DISCA S  
IP20 led module 8w 2700K 800 lm
- DISCA L  
IP20 led module 8w 2700K 800 lm
- DISCA T  
IP20 E27 led bulb 6w 2700K 600 lm

Phase-cut dimming.

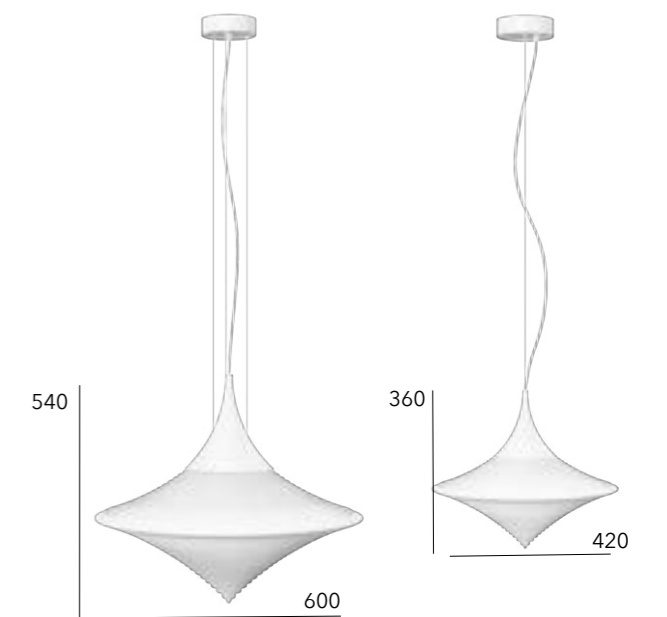

DISCA L

DISCA S

09

# YA-YA

Design by Hind Rabii / 2017

YA-YA is determined to be at the centre, at the heart of places, a long fresco or hooked on modest surfaces.

Its lights are all in suggestive and subtle mother-of-pearl corollas.

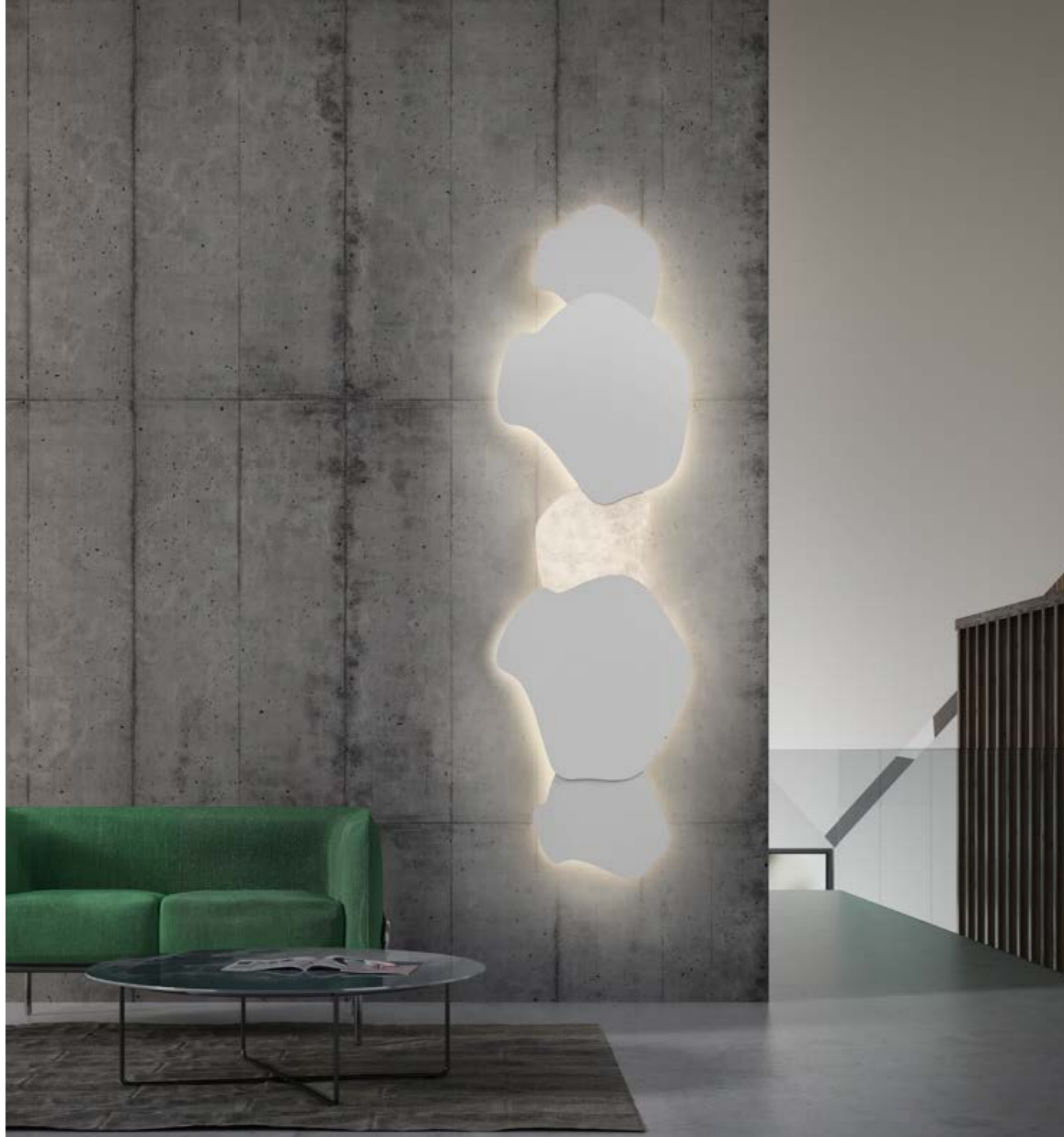







# YA-YA



# YA-YA

## FINISHES

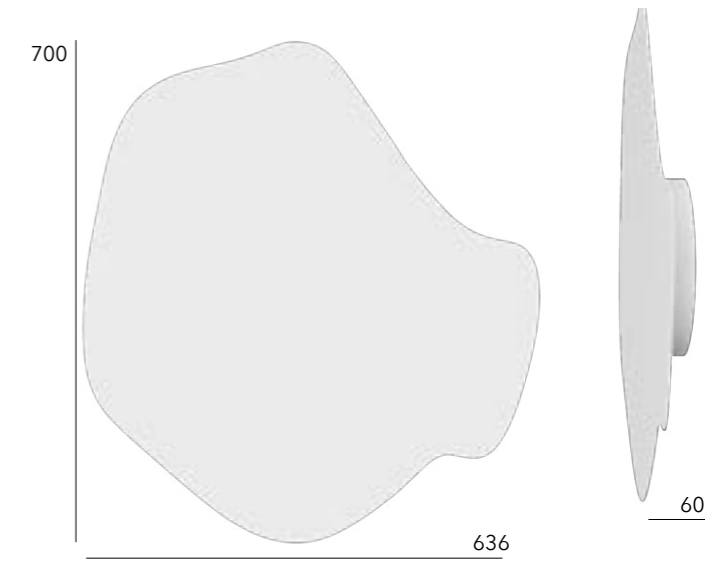
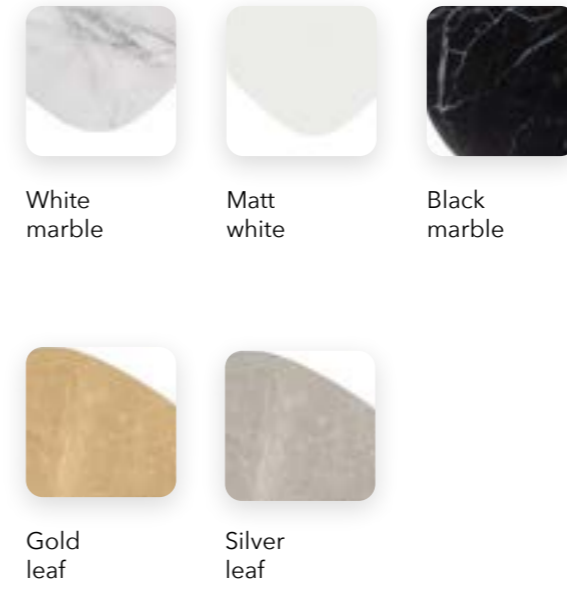

YA-YA 70



YA-YA 3



YA-YA 2

YA-YA 1

## TECHNICAL

- YA-YA 1 - YA-YA 2 - YA-YA 3  
IP20 led module 10w 2700K 1500 lm

- YA-YA 70  
IP20 led module 18w 2700K 2500 lm

Phase-cut dimming.

10

# ICE ABSOLUT

Design by Hind Rabii / 2015

A non-Belgian may not yet be able to imagine an ICE, a sweet (praline in «Belgian»). The ICE Absolut enjoys that kind of roundness that captures the senses, brimming with excitement. It is bursting with light, ready to explode in every direction or to be encased in its desires by golden or silver corsets. ICE is as asteroid of light coming from nowhere, coming from elsewhere.

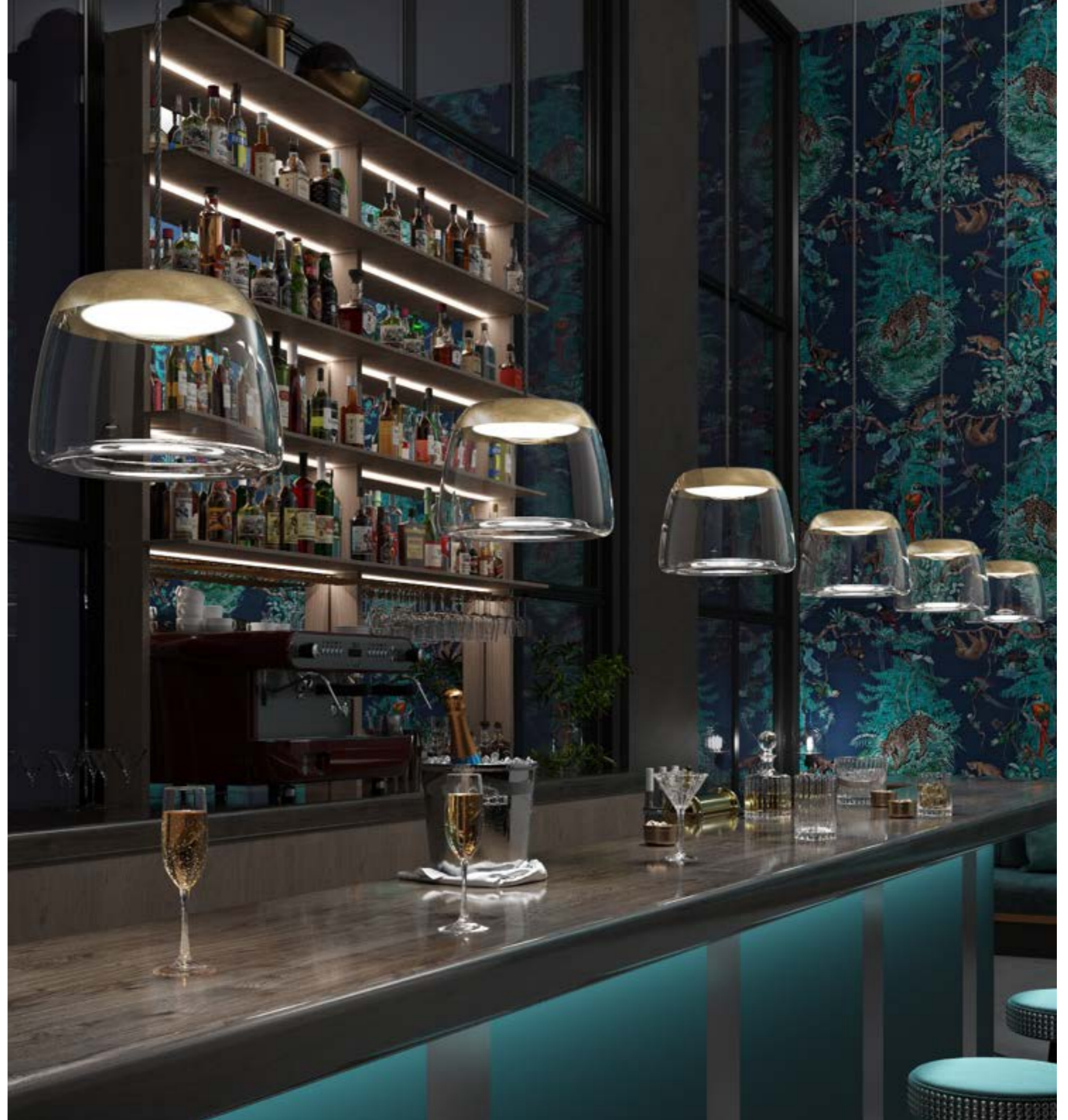



Ice Absolut S Black



Ice Absolut S Mat white

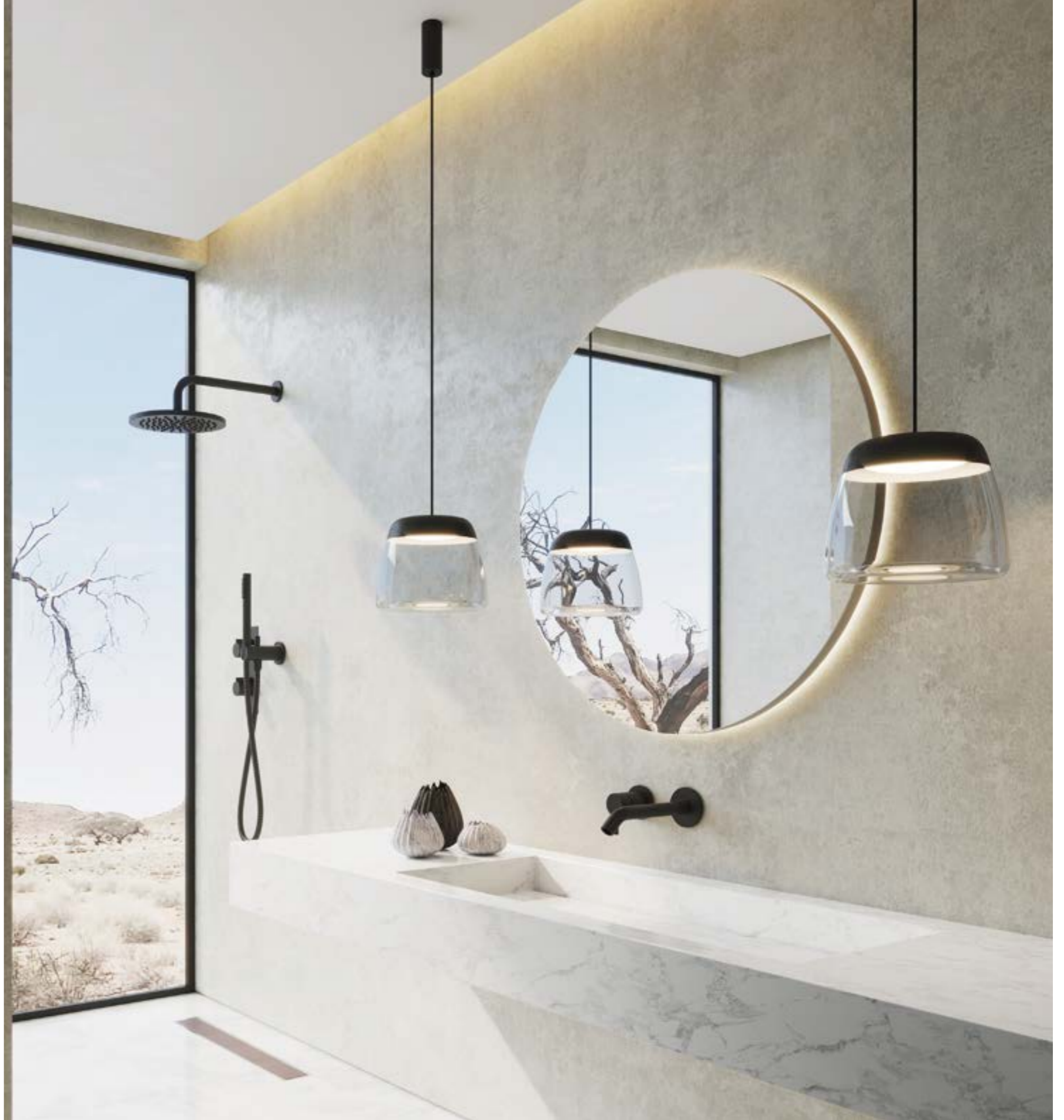

# ICE ABSOLUT

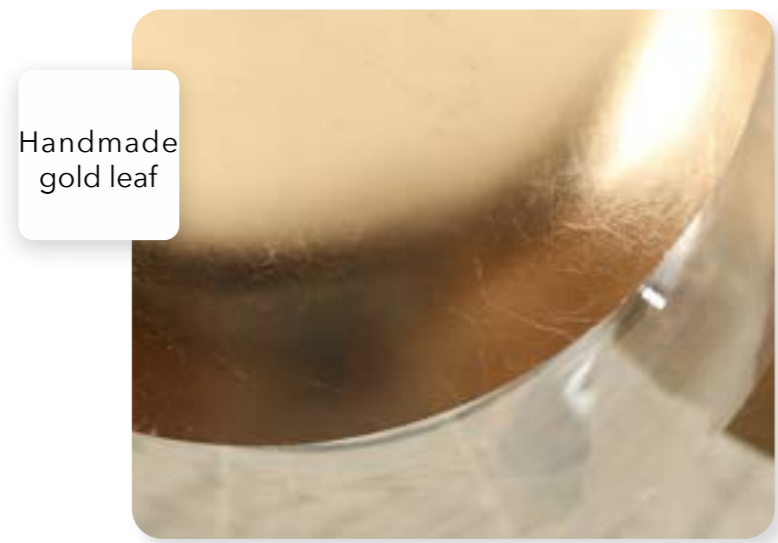

# ICE ABSOLUT

## GLASS FINISH



White

Black



Silver leaf

Gold leaf

## TECHNICAL

**-ICE ABSOLUT S**  
IP20 led module 10w 2700K 1000 lm

**-ICE ABSOLUT L**  
IP20 led module 17w 2700K 1700 lm

Phase-cut dimming.



# ESPRIT YAYA

Design by Hind Rabii / 2017

Forms free from the restrictive tenets of fashion, for now there are three, expressing themselves as mischievous yet aware of their formal presence.

YA-YA is mischievous and ironic, its dual personality endearing. YA-YA wears its materials with such timeless elegance that they could be «anything».

The rays projected onto its surfaces light up the most colorless mediums and give them graphic presence.





Esprit YAYA Gold



# ESPRIT YA-YA

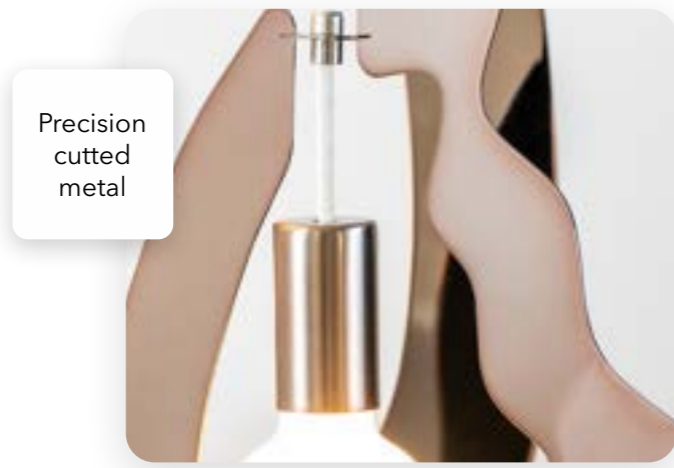

Precision cutted metal

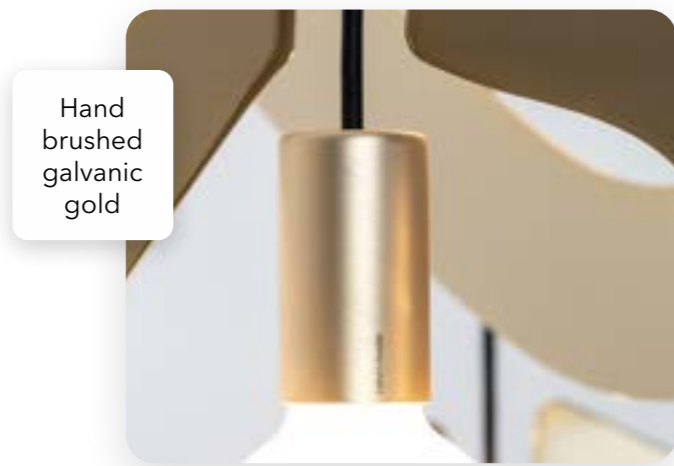

Hand brushed galvanic gold

# ESPRIT YA-YA

## FINISHES



Shiny gold



Shiny bronze

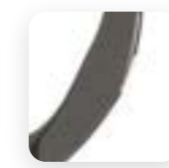

Black chrome

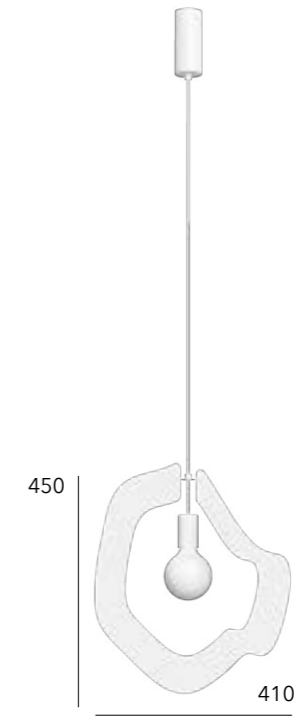

ESP YA-YA 1

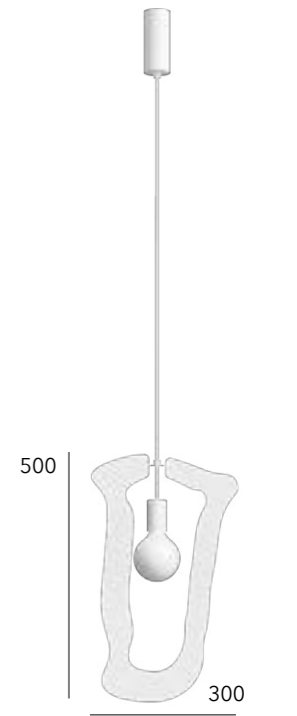

ESP YA-YA 2

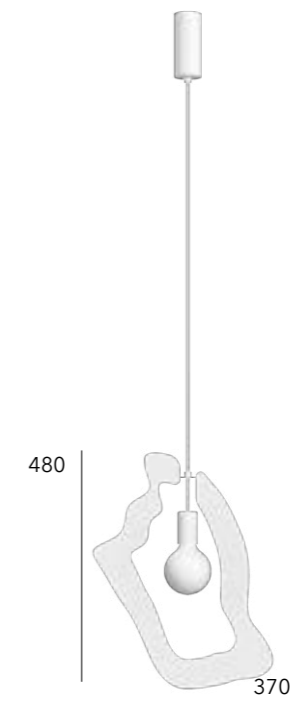

ESP YA-YA 2

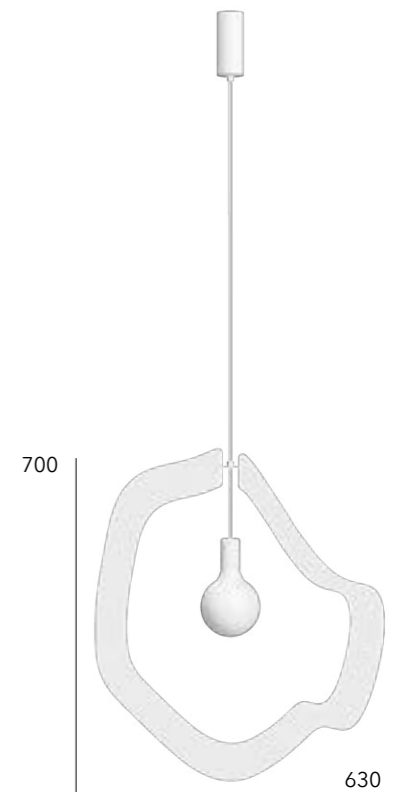

ESP YA-YA 70

## TECHNICAL

**-ESP YA-YA 1 -ESP YA-YA2 -ESP YA-YA 3**  
IP20 E27 Led Bulb 6,5w 2500K 450 lm

**-ESP YA-YA 70**  
IP20 E27 Led Bulb 6,5w 2500K 550 lm

Phase-cut dimming.



12

# ANNA BELLE

Design by Hind Rabii / 2017

ANNA-BELLE is endowed with an extremely rare elegance. The textiles enjoy a whiteness nuanced by the material used and the crown says a little too much of the purity of its intentions.

For BELLE, seducing you is banal.

The oak, an eternal and timeless material, turned towards MORANDI, is the only «support» that suits it. It'll give your home a presence that's both luminous and strong.





# ANNA BELLE

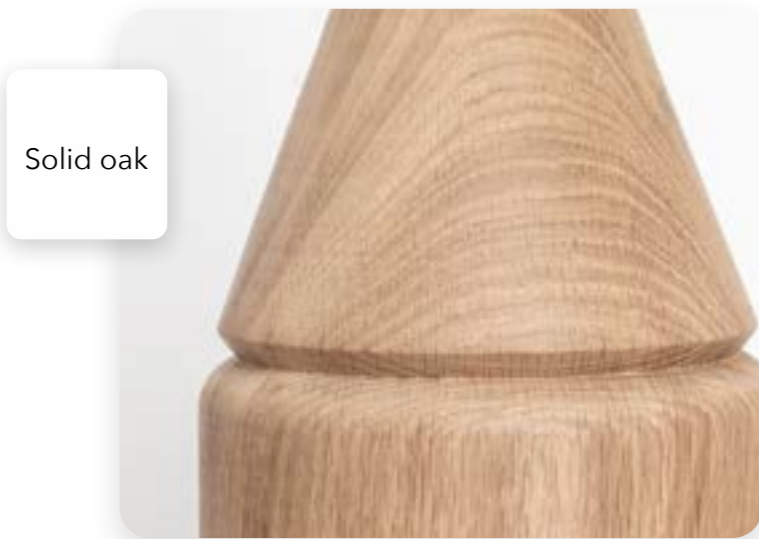

Solid oak



Closed diffusing shade

# ANNA BELLE

## BASE

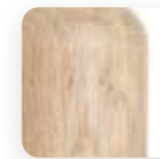

Natural

## SHADE



White

## TECHNICAL

- ANNA BELLE 2  
IP20 E27 led bulb 3x10w 2700K 2400 lm
- ANNA BELLE 3  
IP20 E27 led bulb 13w 2700K 1500 lm
- ANNA BELLE 5  
IP20 E27 led bulb 3x10w 2700K 2400 lm

Cable plug with dimmer switch.

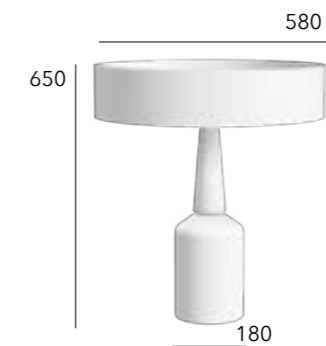

ANNA BELLE 2



ANNA BELLE 3

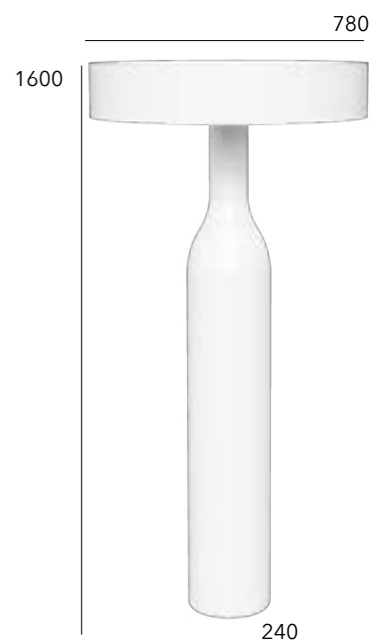

ANNA BELLE 5

13

# NEWELS

Design by Hind Rabii / 2014

Newel is an essential pendant, free to move, essential as an accessory needed to finish a scenography.

Made of metal, available in a range of finishes: Bronze, gold and black chrome, finished by galvanisation.

Like a jewel, it shines with its own light thanks to its luminous body with a warm led light. A unique artistic creation that is a precious addition to any environment.





# NEWELS

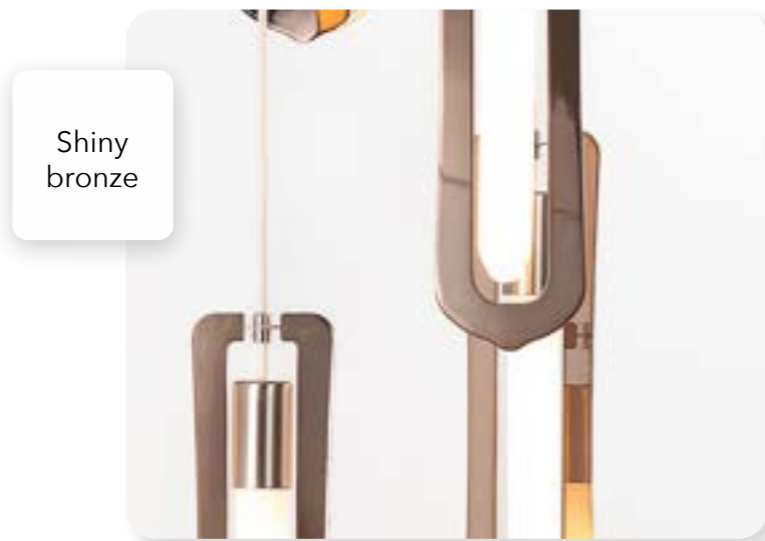
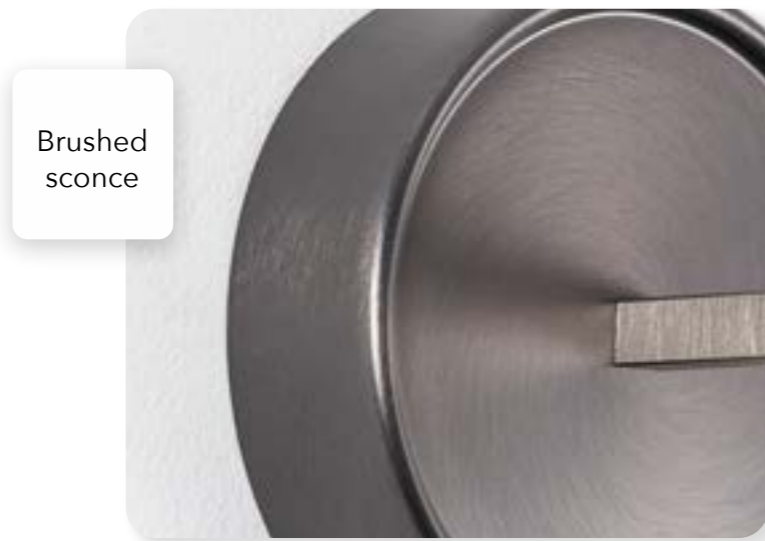

# NEWELS

## FINISH

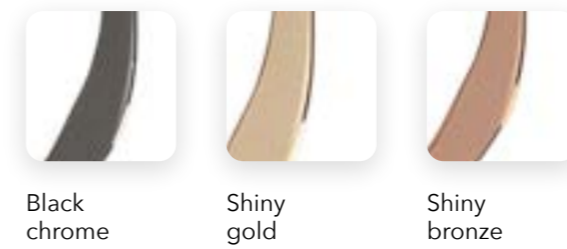

## TECHNICAL

- NEWEL WALL  
IP20 E27 T30 led bulb 5w 2500K 450 lm
- NEWEL  
IP20 E27 T30 led bulb 5w 2500K 450 lm

Phase-cut dimming.

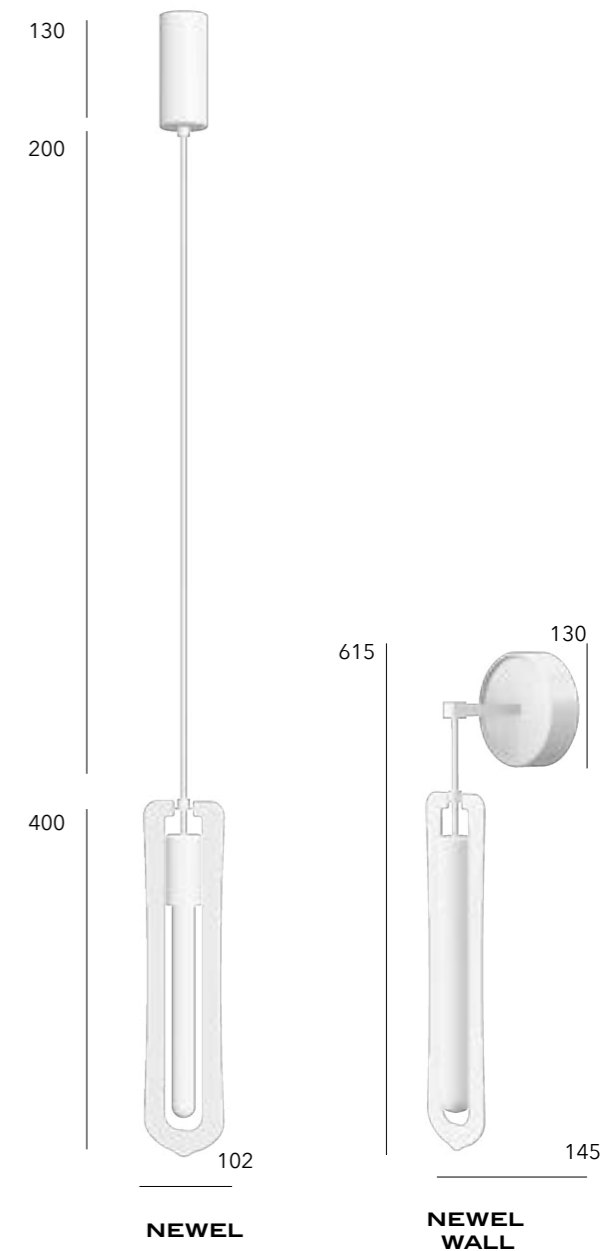

14

# 3x3x3

Design by Hind Rabii / 2014

Combination of three shapes inspired by nature, mountains and childhood : the bell, the spinning top and the cheese wheel. The metal is brushed for the most beautiful effect.





3x3x3 Wall



3x3x3 Gold



3 X 3 X 3



3 X 3 X 3

FINISH



Brushed  
gold

TECHNICAL

- C1**  
IP20 E27 led bulb 12w 2700K 1055 lm
- M1**  
IP20 led module 10w 2700K 1000 lm
- T1**  
IP20 E27 led bulb 15w 2700K 1500 lm

Phase-cut dimming.

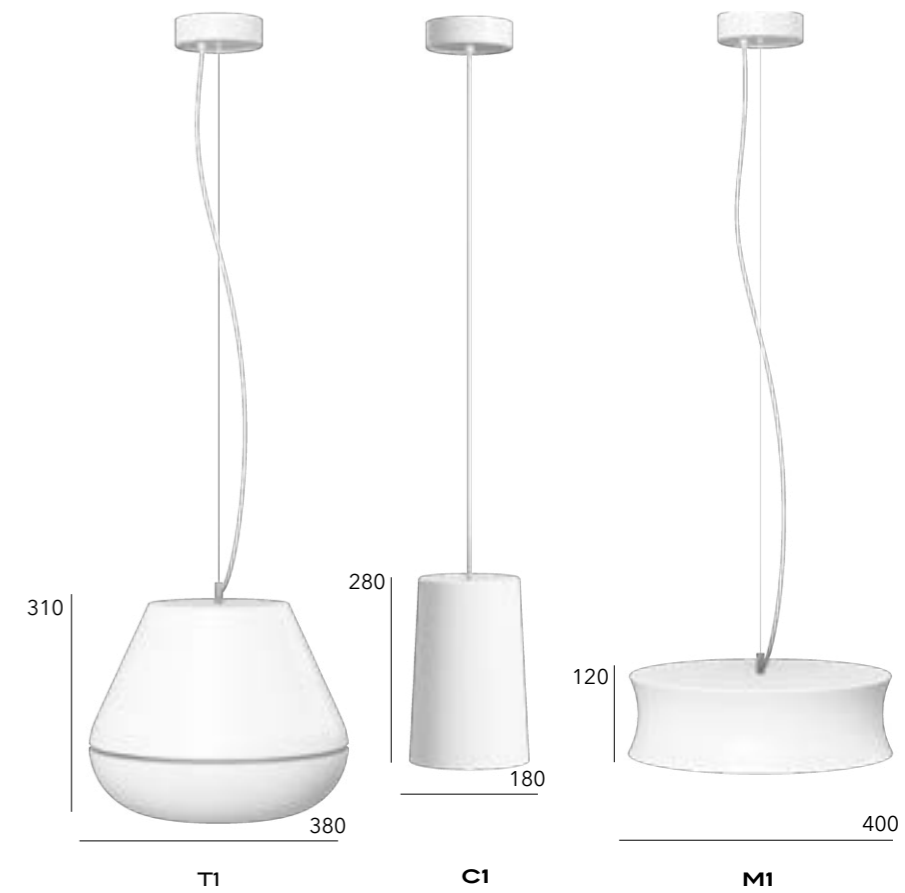

# 3x3x3 WALL

Design by Hind Rabii / 2017

3x3x3 wall is naturally present to protect light as we protect a treasure.

the light comes up and down, an opal glass hides the source for a n optimal diffusion.

3x3x3 wall comes in galvanic finishes, hand brushed, it exists in gold, bronze and a particular fumé blue.



# 3 X 3 X 3 WALL



# 3 X 3 X 3 WALL

## GLASS FINISH

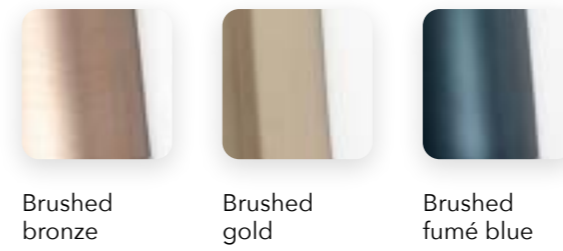

## TECHNICAL

**-3x3x3 Wall**  
IP20 G9 Led 2\*5W 2700K 900 lm  
Phase-cut dimming.



# TENUE DE SOIREE

Design by Hind Rabii / 2015

The visual impacts of Tenue de Soirée are impressed in large-scale on the emotion.

They open up the space to romantic, phantasmagorical figures and surround the light with graphic vibrations .

A selection of fabrics , bamboo and other materials, makes Tenue de Soirée changing without any limit.





Tenue de soirée Finesse



Tenue de soirée  
Insolence-Mood-Madagascar

# TENUE DE SOIREE

Design by Hind Rabii / 2015



We use the finest fabrics and materials from Belgian, French and Italian Editors. Most of materials used are handmade with natural bamboo, linen and other delicate materials as hemp. The only limit for combinations of Tenue de Soirée is Imagination.

# TENUE DE SOIRÉE

Linen and bamboo



Diffusor detail



# TENUE DE SOIRÉE

## SHADE

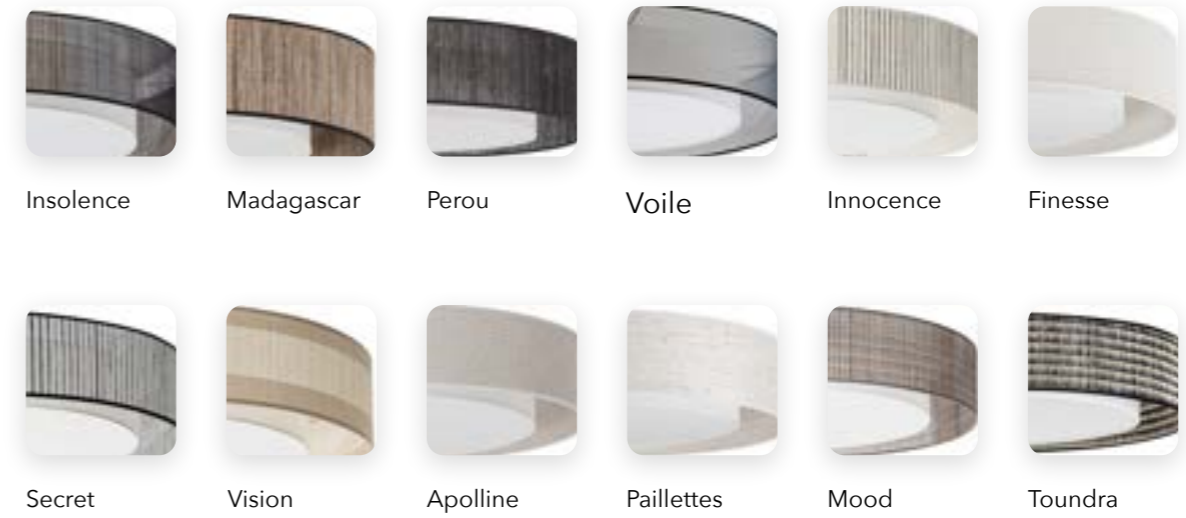

## TECHNICAL

**-WLG3000**  
 IP20 E27 led bulb 3x10w 2700K 2400 lm  
**-WLG3600**  
 IP20 E27 led bulb 3x15w 2700K 4500 lm  
 Phase-cut dimming.



16

# OND'A

Design by Hind Rabii / 2018

Like a flying UFO, Ond'a is of a fluid and airy simplicity while being precious by its materials and the artisanal work of its finishes.



Ond'A Black & Gold





Ond'A Vestita Innocence



# OND'A

Gold leaf detail



Fineness of materials



# OND'A

## SHADE



Black on gold



Black on silver



White on gold

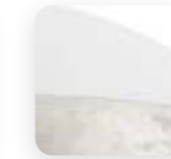

White on silver

## OND'A VESTITA

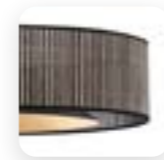

Insolence

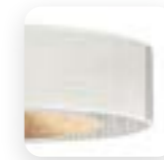

Innocence

## TECHNICAL

**-OND'A S**  
IP20 led module 17w 2700K 2200 lm

**-OND'A L**  
IP20 led module 25w 2700K 3000 lm

**-OND'A VESTITA**  
IP20 led module 17w 2700K 2200 lm

Phase-cut dimming.

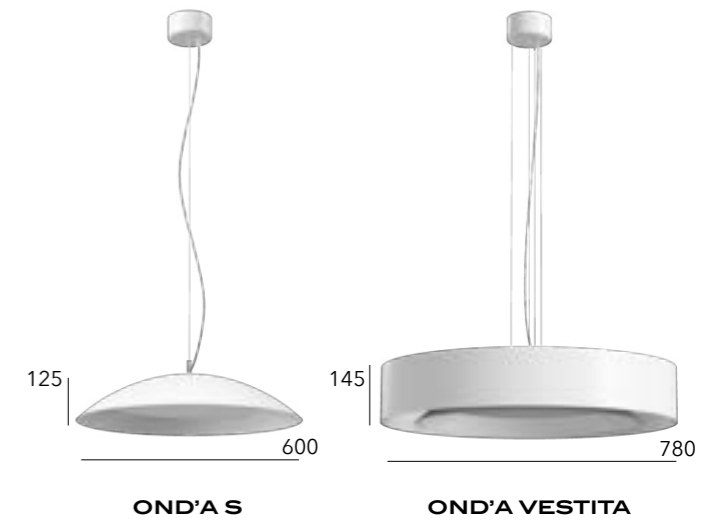

OND'A S

OND'A VESTITA

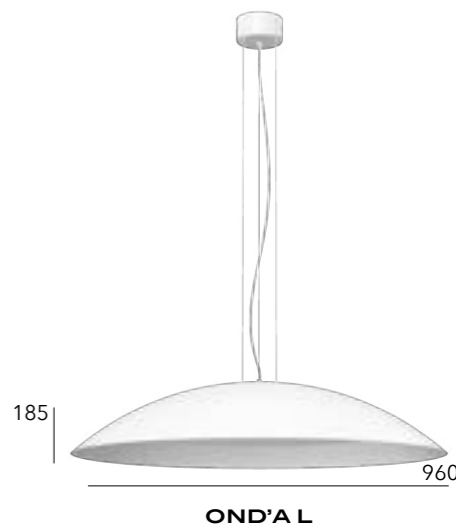

OND'A L

17

# ICE DONNA

Design by Hind Rabii / 2017

Ice Donna is elegant as a lady could be. A long tube with a solid brass base makes Ice Donna so particular. The light comes from the reflector that divides the light for best efficiency.





# ICE DONNA

Solid brass  
base



Anodised  
aluminium



## STRUCTURE



Black

## SHADE

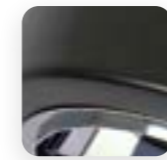

Black with  
dark grey  
reflector

## TECHNICAL

**-ICE DONNA S**  
IP20 led module 8w 2700K 800 lm

**-ICE DONNA L**  
IP20 led module 8w 2700K 800 lm

Cable plug with dimmer switch.

# ICE DONNA

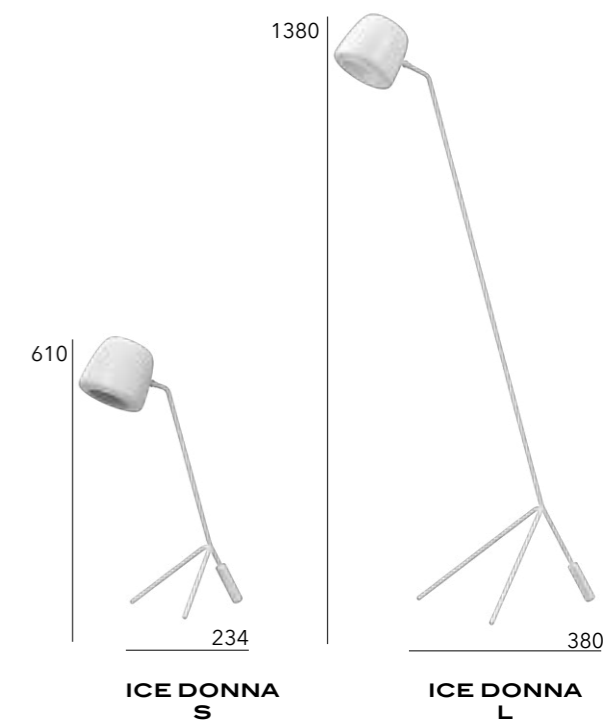



# ICE WALL

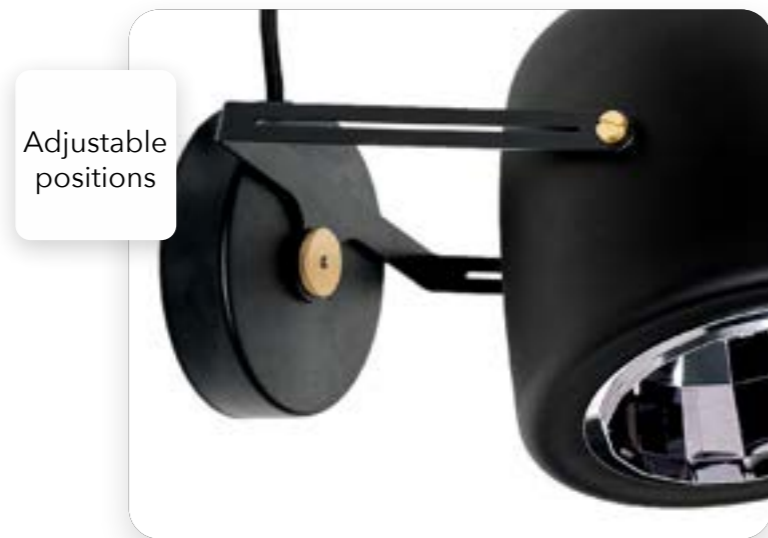
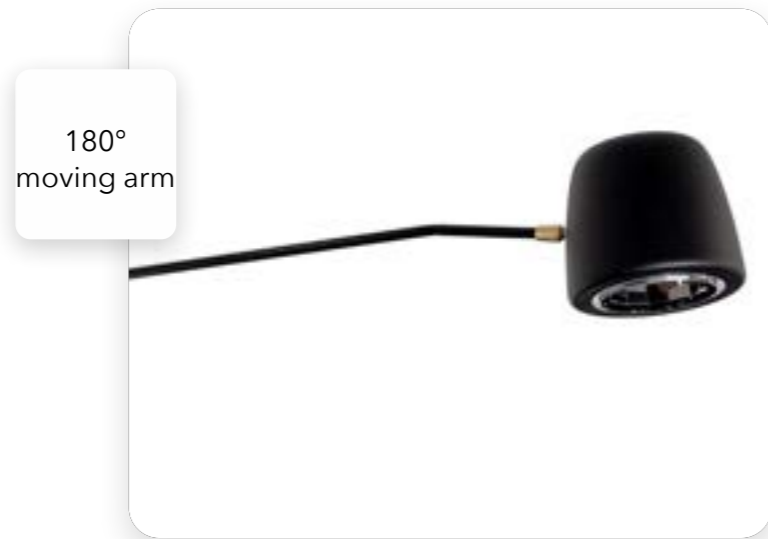

## STRUCTURE



Black

## SHADE

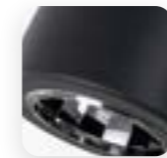

Black with dark grey reflector

## TECHNICAL

- ICE A30**  
IP20 led module 8w 2700K 800 lm
- ICE A58**  
IP20 led module 8w 2700K 800 lm
- ICE A78**  
IP20 led module 8w 2700K 800 lm
- ICE A120**  
IP20 led module 8w 2700K 800 lm

Phase cut dimming.

# ICE WALL



**ICE A30**



**ICE A58**



**ICE A78**



**ICE A120**

18

# REFLECTORS

Design by Hind Rabii / 2014

REFLECTOR(S), collection of pendants and wall lamps, with an ample choice of heights and diameters, so that the lamps can be combined to create light effects of varying intensity. Cylindrical shade made from velvet or printed fabric in different variants.

Metal reflector in aluminium.







# REFLECTOR WALL

Design by Hind Rabii / 2015



The wall version of Reflector plays with light, thanks to a mouth blown glass, half chromed in silver. The light is indirect and is reflected a number of times inside the anodised reflector. The effect is magic.

# REFLECTOR(S)



# REFLECTOR(S)

## SHADE

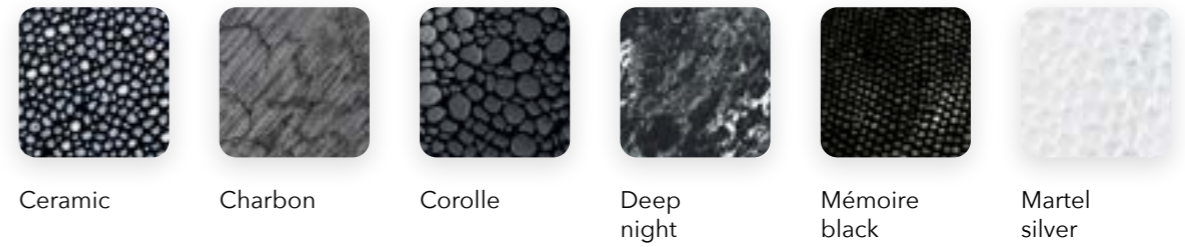

## BESPOKE

A big choice of finishes is available in our box sample.

## REFLECTOR

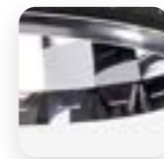

Carbon

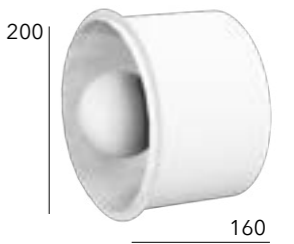

REFLECTOR WALL

## TECHNICAL

**-RLB 130-RLB140-RLB218-RLB235-RLB250**

IP20 led module 8w 2700K 800 lm

**-REFLECTOR WALL**

IP20 G9 Led bulb 5w 2700 K 500 lm

Phase-cut dimming.

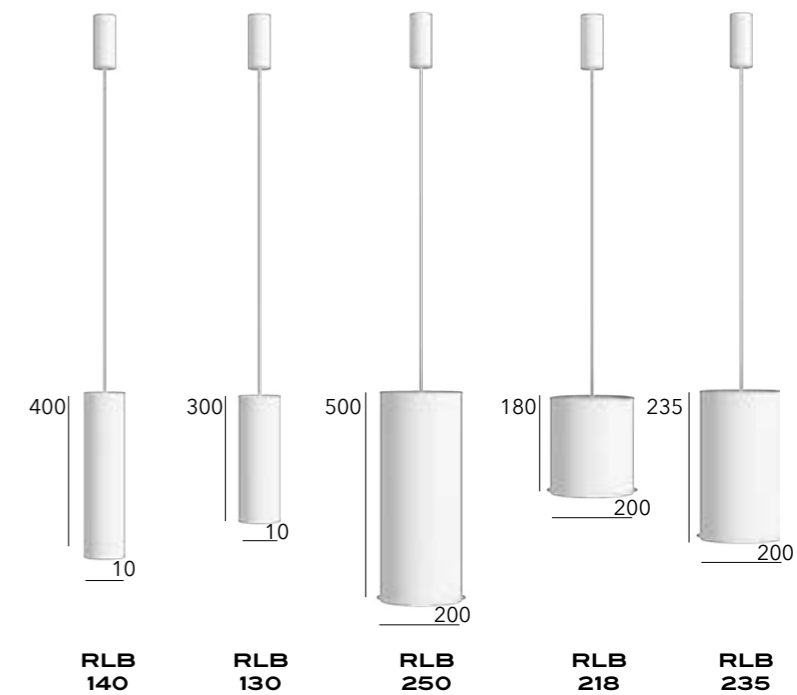

# TOP REFLECTORS

Design by Hind Rabii / 2017



# TOP-REFLECTOR

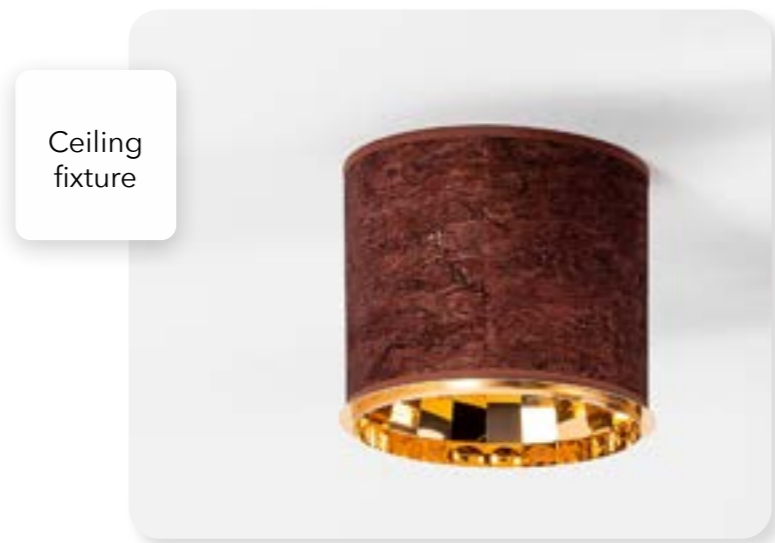
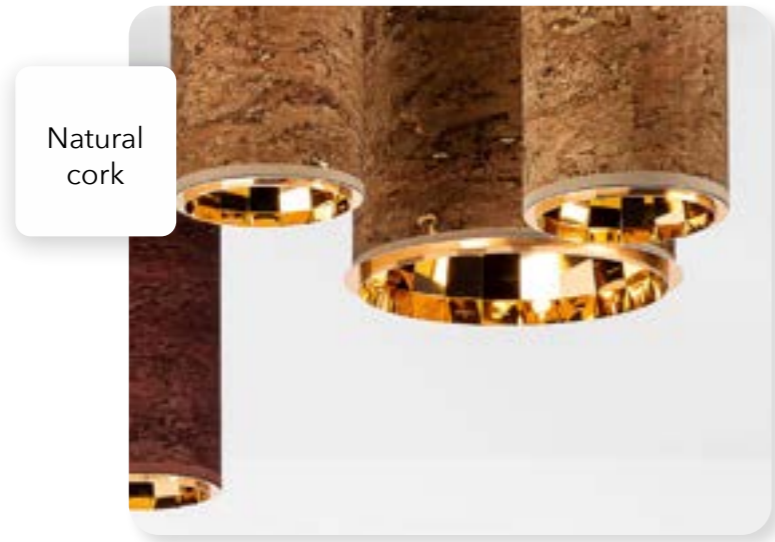

# TOP-REFLECTOR

## SHADE

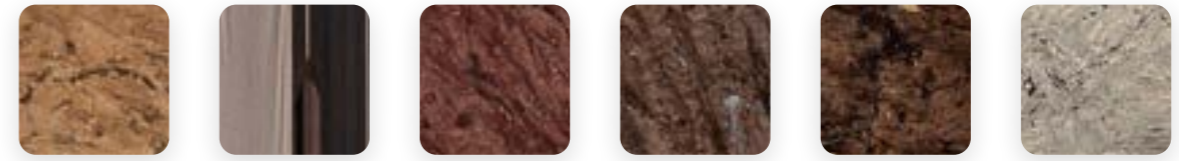

Desert

Deep bronze

Vino

Luxe silver

Luxe gold

Ecorce

## BESPOKE

A big choice of finishes is available in our box sample.

## REFLECTOR

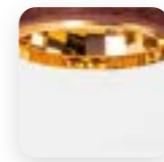

Copper

## TECHNICAL

### -TPR118

IP20 led module 8w 2700K 800 lm

### -TPR125

IP20 LED MODULE 8W 2700K 800 lm

### -TPR216

IP20 led module 8w 2700K 800 lm

Phase cut dimming.

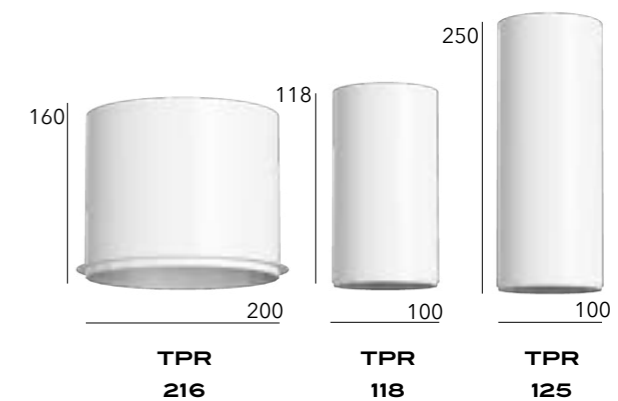

# LET ME READ

Design by Hind Rabii / 2022

Let Me Read is a concept.  
Combination of wall lamp and hanging light, a play of different colors and a mix of two functions.  
Free of limits, free of space, the suspension may take place anywhere.



# LET ME READ

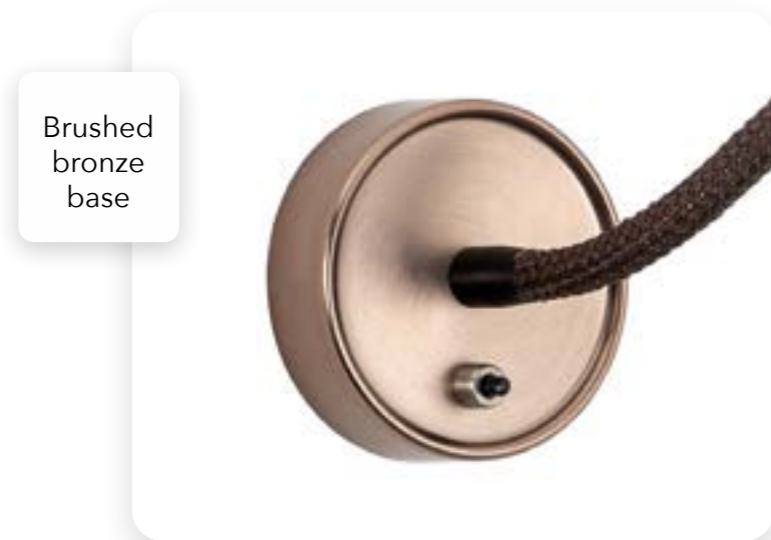

# LET ME READ

## WALL SCONCE

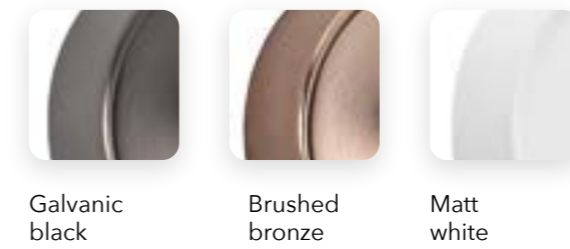

## FLEX

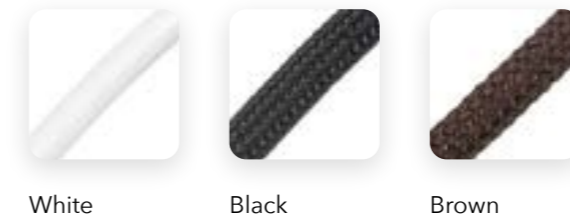

## TECHNICAL

**-LMR01-25**  
IP20 led 3W + lens 2700 K

**-LMR01-50**  
IP20 led 3W + lens 2700 K

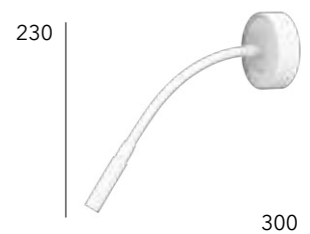

LMR01-25



LMR01-50

## **HIND RABII SRL**

Warehouse :  
Rue Bronde 2 4801 ZI Stembert  
Belgium

**t.** +32 87 22 93 74  
**e.** [info@hindrabii.com](mailto:info@hindrabii.com)  
**w.** [hindrabii.eu](http://hindrabii.eu)

Copyright HIND RABII 2022 ®  
Design - graphics - scenography : Hind Rabii and Michel Orban  
Photos :  
Michel Orban  
Serge Anton  
Luc Viatour